

**AMENDMENT NO. 1 TO
Monte Bella Maintenance District
AGREEMENT BETWEEN
SMITH & ENRIGHT LANDSCAPING, INC., AND CITY OF SALINAS**

This Amendment No. 1 to the **Monte Bella Maintenance District** Agreement is entered into this 25th day of June 2024, by and between the City of Salinas (the "City") and Smith & Enright Landscaping, Inc., (the "Contractor"). City and Contractor may be individually referred to herein as a "Party" and collectively the City and Contractor may be referred to as the "Parties."

RECITALS

WHEREAS, the City and Contractor first entered into an agreement for Monte Bella Maintenance District effective June 22, 2021, pursuant to which Contractor agreed to act as and provide certain services to the City for compensation (the "Agreement"); and

WHEREAS, pursuant to Resolution 22149 (N.C.S.) the City Council awarded an agreement to Contractor for a three (3) year term, with the option for an additional two (2) year term with an inflation rate increase per the ENR Cost Index; and

WHEREAS, on February 15, 2024, Contractor submitted a written request to exercise the option for an additional two (2) year term with the request of the ENR Cost Index of 5% or less. The new cost for Monte Bella Maintenance District will increase \$312.00 monthly from \$6,240.00 to \$6,552.00 per month.

NOW, THEREFORE, in mutual consideration of the terms and conditions set forth below, the Parties agree as follows:

TERMS

1. The term of the Agreement is hereby extended for a two-year period commencing on July 1, 2024, and ending on June 30, 2026.
2. The total amount of compensation to be paid by the City to the Contractor under the Agreement is hereby increased by \$312.00 per month to \$6,552.00 per month, for a total amount of annual compensation not to exceed \$78,624.00.
3. All other covenants, terms, and conditions set forth in the Agreement and not amended by this Amendment No. 1 shall remain in full force and effect as if fully set forth herein.

IN WITNESS WHEREOF, the undersigned, as authorized representatives of the City and Contractor have entered into this Agreement as of the date first written above.

CITY OF SALINAS

DocuSigned by:

49009f9344b6488...
Rene Mendez, City Manager

APPROVED AS TO FORM:

DocuSigned by:

Christopher D. Callihan

DF600E62871844E...

- Christopher Callihan, City Attorney
- Rhonda Combs, Assistant City Attorney

Smith & Enright Landscaping, Inc.

DocuSigned by:

Selena Herrin

313BC21CA58A4C8...

Printed name: Selena Herrin
Title: general manager

INVITATION TO BID
LANDSCAPE SERVICES FOR
MONTE BELLA MAINTENANCE DISTRICT

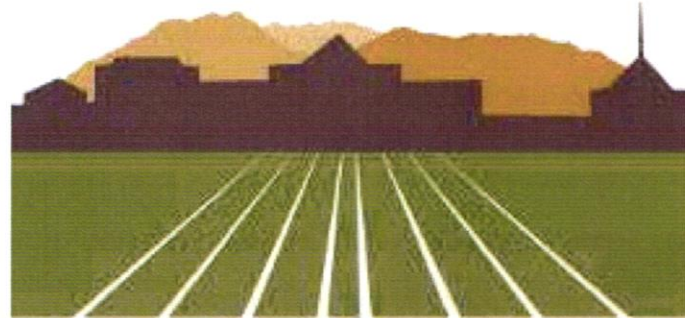

SALINAS

RICH IN LAND | RICH IN VALUES

CITY OF SALINAS
200 Lincoln Avenue
Salinas, CA 93901

For use in conjunction with STANDARD SPECIFICATIONS, DESIGN STANDARDS AND
STANDARD PLANS, 2008 Edition, City of Salinas-Public Works Department.

TABLE OF CONTENTS

<u>SECTION</u>	<u>PAGE NO.</u>
INVITATION TO BID	1
LOCATION MAP.....	5
NOTICE TO BIDDERS	6
PART A – BID CONTRACT DOCUMENTS	10
CONTRACT DOCUMENTS TO BE SUBMITTED WITH BID ON BID OPENING DATE	11
PROPOSAL.....	12
BIDDER’S STATEMENT OF FINANCIAL RESPONSIBILITY, TECHNICAL ABILITY AND EXPERIENCE	18
NON-COLLUSION DECLARATION OF CONTRACTOR	19
INSURANCE CERTIFICATION	20
BIDDER’S STATEMENT OF SUBCONTRACTORS – PART I	21
CONTRACT DOCUMENTS TO BE SUBMITTED TO THE CITY WITHIN 5 WORKING DAYS AFTER BID OPENING DATE	22
BIDDER’S STATEMENT OF SUBCONTRACTORS – PART II.....	23
NON-COLLUSION DECLARATION OF SUBCONTRACTOR	25
STATEMENT OF GOOD FAITH EFFORT FOR LOCAL HIRE	26
BIDDER’S LIST FOR THE CITY OF SALINAS PUBLIC WORKS DEPARTMENT	27
PART B – SUCCESSFUL BIDDER’S CONTRACT DOCUMENTS TO BE SUBMITTED AFTER PROJECT IS AWARDED	28
GENERAL INSTRUCTIONS TO LOW BIDDER	29
PAYMENT BOND (LABOR AND MATERIAL BOND).....	31
AGREEMENT	33
PUBLIC WORKS CONTRACT AWARD INFORMATION (D.A.S. 140)	40
PART C – CITY OF SALINAS FORMS AND MEMORANDUM DOCUMENTS	41
INSTRUCTIONS FOR PREPARATION OF STATEMENT OF COMPLIANCE	42
STATEMENT OF COMPLIANCE	43
CITY OF SALINAS FRINGE BENEFIT STATEMENT	44
LOCAL HIRING RESIDENCY COMPLIANCE DOCUMENTATION.....	46
PUBLIC WORKS DEPARTMENT BID PROTEST.....	47
CITY OF SALINAS NOTICE OF POTENTIAL CLAIM	48
SUBCONTRACTOR SUBMITTAL FORM	49
PART D – SPECIAL PROVISIONS.....	50
SECTION 1 SPECIFICATIONS.....	51
SECTION 2 PROPOSAL REQUIREMENTS AND CONDITIONS.....	51
2-1.01 GENERAL	51
2-1.02 EXAMINATION OF SPECIFICATIONS, CONTRACT AND SITE OF WORK....	52
2-1.03 UNSCHEDULED / EXTRA WORK RATES	53
2-1.04 BID PROTEST FEE	54

SECTION 3 AWARD AND EXECUTION OF CONTRACT	55
SECTION 4 BEGINNING OF WORK, TIME OF COMPLETION, LIQUIDATED DAMAGES AND TEMPORARY SUSPENSION OF WORK	55
SECTION 5 GENERAL	56
SECTION 5-1 MISCELLANEOUS	56
5-1.01 LABOR NONDISCRIMINATION	56
5-1.02 WAGE DETERMINATION.....	56
5-1.03 ENFORCEMENT OF THE CITY’S LOCAL HIRING ORDINANCE REQUIREMENTS	57
5-1.04 DIR REGISTRATION.....	57
5-1.05 SUBCONTRACTING	57
SECTION 5-2 QUALITY ASSURANCE	57
SECTION 5-3 PAYMENT	60
SECTION 5-4 RESPONSIBILITIES AND MAINTAINING TRAFFIC	60
SECTION 6 BLANK	63
SECTION 7 MATERIALS	63
7-1.01 MISCELLANEOUS	63
7-1.02 GENERAL	63
SECTION 8 BLANK	63
SECTION 9 DESCRIPTION OF PROJECT	63
SECTION 9-1 SITE DESCRIPTION	63
SECTION 10 CONSTRUCTION DETAILS	64
SECTION 10-1 GENERAL	64
10-1.01 ORDER OF WORK	64
10-1.02 LEGAL.....	64
10-1.03 INSPECTION AND CONTROL OF WORK.....	64
10-1.04 FINAL INSPECTION AND CLEANUP.....	64
10-1.05 WORKMANSHIP	65
10-1.06 PROGRESS SCHEDULE.....	65
10-1.07 OBSTRUCTIONS	65
10-1.08 UTILITY DETERMINATION.....	65
10-1.09 EXAMINATION OF SITE.....	66
10-1.10 WATERING	66
10-1.11 CONSTRUCTION EASEMENTS	66
10-1.12 PARTIAL PAYMENTS AND RETENTION	66
10-1.13 ARBITRATION.....	67
10-1.14 NOTICE OF POTENTIAL CLAIM	67
10-1.15 CLAIMS.....	68
10-1.16 PUBLIC CONTRACTS CODE 9204 PUBLIC WORKS PROJECT.....	68
10-1.17 “9204.....	68
10-1.18 DUST CONTROL	71
10-1.19 RECYCLING AND CLEANUP.....	71
10-1.20 TRAFFIC CONTROL	72
10-1.21 GENERAL	72
10-1.22 CHANGES IN WORK	73
10-1.23 PRESERVATION OF PROPERTY	73
10-1.24 ENVIRONMENTAL/POLLUTION PREVENTION REQUIREMENTS.....	73
10-1.25 MOBILIZATION.....	74

SECTION 11 LANDSCAPE MAINTENANCE.....	74
SECTION 11-1 DEFINITIONS.....	74
SECTION 11-2 HAULING.....	86
SECTION 11-3 UNSUITABLE MATERIAL.....	86
SECTION 11-4 PAYMENT.....	86
SECTION 12 TEMPORARY TRAFFIC SIGNAGE.....	86
SECTION 12-1 GENERAL.....	86
SECTION 12-2 TEMPORARY TRAFFIC SIGNS.....	86
SECTION 13 BLANK.....	86
SECTION 14 CONTROL OF WORK.....	86
SECTION 14-1 GENERAL.....	86
SECTION 14-2 PAYMENT OF LANDSCAPE MAINTENANCE.....	87
SECTION 14-3 SCHEDULE OF WORK.....	88
14-3.01 WORK SCHEDULE.....	88
SECTION 14-4 INSPECTIONS.....	89
SECTION 15 MEASUREMENT AND PAYMENT.....	89
PART E - CONSTRUCTION SITE BEST MANAGEMENT PRACTICES, CONSTRUCTION AND DEMOLITION DIVERSION REQUIREMENTS, EROSION AND SEDIMENT CONTROL PLAN REQUIREMENTS AND OTHER MISCELLANEOUS INFORMATION	91
PART F – TECHNICAL SPECIFICATIONS.....	98
PART G– APPENDIX	101

LOCATION MAP



NOTICE TO BIDDERS

Notice is hereby given that the City of Salinas, County of Monterey, State of California (hereinafter referred to as "City"), hereby invites sealed Bid Proposals for the following work to be completed according to Plans and Specifications on file, adopted therefore, to wit:

LANDSCAPE SERVICES FOR MONTE BELLA MAINTENANCE DISTRICT

A scanned copy of the Bid Proposal Package ("Bids") for the above-mentioned work shall be submitted electronically via the PlanetBids website until **2:00 p.m.** Pacific Standard Time on May 25th 2021, at which time or thereafter said bids will be electronically opened and available online. A link to the meeting will be made available through PlanetBids. **It is the Bidder's responsibility to ensure that said Bid shall be fully uploaded / transmitted via the PlanetBids website, prior to the aforementioned designated date and time. The City will not be accepting paper bids.**

Disability-related modification or accommodation, including auxiliary aids or services, may be requested by any person with a disability who requires a modification or accommodation in order to participate in any meetings for this project. Requests should be referred to the City Clerk's Office at City Hall, 831-758-7381, as soon as possible but by no later than 5 p.m. of the last business day prior to the scheduled meeting. Hearing impaired or TTY/TDD text telephone users may contact the City by dialing 711 for the California Relay Service ("CRS") or by telephoning any other service providers' CRS telephone number.

No Bid shall be accepted from a Contractor who has not been licensed in accordance with the Provisions of Chapter 9 of Division 3 of the Business and Professions Code. Also, he/she is required to comply with all the requirements of the City of Salinas local hiring preference Ordinance 2330, Salinas City Code Chapter 12, Article IV, attached hereto, **STATEMENT OF GOOD FAITH EFFORT FOR LOCAL HIRE** and incorporated herein by reference, with respect to person(s) hired directly by the Contractor and to all persons hired by the Contractor's Subcontractor(s). **Contractor shall possess a Type "{ C-27, Type C-61/D-49}" license or other license qualifying the Bidder to Bid as a prime Contractor prior to SUBMITTAL of Bid and the license must be valid prior to award and throughout the Contract as approved by Council.**

In determining the lowest bid for a public works contract that exceed \$5,000.00, a qualified local business shall receive a five-percent (5%) preference, per the City's Local Purchasing Preference Ordinance (Sec. 12-28.050 and Sec. 12-28.060).

In order to be recognized as a local business, Contractors must submit a Declaration of Local Business Form to the City's Finance Department.

The City of Salinas reserves the right to reject any or all Bids and to waive any informality in Bids received.

By submitting a Bid, it is assumed that the Contractor has evaluated the site and the Bid submitted reflects that the Contractor is satisfied as to the existing conditions, said conditions being reflected in the Bid.

Each Bid shall be in accordance with the Specifications adopted therefore, submitted on the Proposal form furnished and accompanied by a certified or cashier's check or Bid Bond made payable to the City of Salinas, for an amount equal to at least *ten percent (10%)* of that amount of the Bid, such guaranty to be forfeited should the Bidder to whom the Contract is awarded fail to enter into the Contract within 15 calendar days after notification of the award of Contract to the Bidder. The undersigned agrees that, in case of his/her default in executing the Contract and the necessary bonds after award and due notice thereof, the said check or bond and the money payable thereon shall become and remain the property of the City of Salinas as liquidated damages. The Contractor shall perform the work for the maintenance of the areas described for a period of three years (36) months from date of contract award.

For any moneys earned by the Contractor and withheld by the City of Salinas to ensure the performance of the Contract, the Contractor may, at his/her request and expense, substitute securities equivalent to the amount withheld in the form and manner and subject to the conditions provided in Section 22300 of the Public Contracts Code of the State of California.

A contractor or subcontractor shall not be qualified to bid on, be listed in a bid proposal, subject to the requirements of Section 4104 of the Public Contract Code or engage in the performance of any contract for public work, as defined in this chapter, unless currently registered and qualified to perform public work pursuant to Section 1725.5 . It is not a violation of this section for an unregistered contractor to submit a Bid that is authorized by Section 7029.1 of the Business and Professions Code or by Section 10164 or 20103.5 of the Public Contract Code, provided the contractor is registered to perform public work pursuant to Section 1725.5 at the time the contract is awarded.

All Contractors (prime and subs) must possess and maintain such registration with the Department of Industrial Relations ("DIR") in order to be awarded and to perform work on public works projects. The following is the link to DIR's Contractor Registration searchable database: <https://efiling.dir.ca.gov/PWCR/Search.action>

A bid shall not be accepted nor any contract or subcontract entered into without proof of the contractor or subcontractor's current registration to perform public work pursuant to Labor Code Section 1771.1.

This project is subject to compliance monitoring and enforcement by the DIR.

Additionally, all contractors and subcontractors must furnish certified payroll records directly to the Labor Commissioner (aka Division of Labor Standards Enforcement) on a weekly basis and in the format prescribed by the DIR, which may include electronic submission.

Bidders will be responsible for printing or obtaining on their own accord, hard copies of the Bid Proposal Package, Plans, Specifications, Prospective Bidders List and any addenda and notifications for their use in submitting a Bid.

Bidders are required to register as a Prospective Bidder for this project on the PlanetBids Vendor Portal website when submitting a Bid and shall maintain their status as "Bidder" throughout the Bid process; Bidders that fail to do so shall be disqualified. Prospective Bidders are permitted to access and download all information and documents available for the project on the PlanetBids website. Only registered **Prospective Bidders** for the particular City of Salinas project will automatically receive updates,

notifications, and addenda when issued, however, it is the Bidders' responsibility to ensure that the forgoing have been received.

Bidders can register as a Prospective Bidder in two ways:

- (1) Bidders are encouraged to register for **FREE** through **PlanetBids Vendor Portal for the City of Salinas** at <https://www.planetbids.com/portal/portal.cfm?CompanyID=22949>,
- (2) Bidders may also register to PlanetBids' website directly for a **FEE** at <https://vendorline.com/register> and sign up for City of Salinas' bid opportunities. The link "View Current Construction Projects Out for Bid" on the City of Salinas website listed below will take you to the registration page on the PlanetBids Vendor Portal for the City of Salinas website: <https://www.cityofsalinas.org/our-city-services/public-works/engineering/construction-projects>

All Specifications are available for viewing at the Public Works Department Office at City Hall and available for download on PlanetBids through the City of Salinas website, <https://www.cityofsalinas.org/our-city-services/public-works/engineering/construction-projects>

For assistance in downloading the documents, contact PlanetBids online or by calling 818-992-1771.

All questions regarding this project shall be submitted to the City of Salinas through the project page on the PlanetBids website, 10 calendar days prior to bid opening date. Questions received after the date stated here shall not be answered. All registered Prospective Bidders for this project will receive an email notification once a response to a question has been posted on the PlanetBids web site.

STANDARD SPECIFICATIONS DESIGN STANDARDS AND STANDARD PLANS, 2008 Edition, City of Salinas, Public Works Department, (herein referred to as the "Standard Specifications") may be purchased from Public Works Department by payment of **\$45.00 (tax included)** per set or may be purchased by mail order for **\$53.00 (tax, shipping and handling included)**; or may be downloaded on the City of Salinas website at no charge at:

<https://www.cityofsalinas.org/file/847/download>

NOTE: For Bid package to be VALID: (1) the Bidder must submit all completely executed and signed City of Salinas forms; (2) the Contractor and all Subcontractors shall have valid, current and active Contractor's license(s) for the classification(s) of work performed; and (3) the Contractor and all Subcontractors must possess and maintain a Public Works Contractor Registration with the DIR pursuant to Labor Code section 1725.5, and the license(s) must be valid at the time Contract is awarded and throughout the Contract as approved by Council.

It is expressly understood and agreed that this Bid shall have the following documents completed, all of which are incorporated into and made a part hereof. **The following information shall be submitted with the Bid Proposal on the Bid Opening Date:**

1. **Complete Proposal signed and dated**
2. **Signed Addendum, if any**
3. **Bid Bond**

4. **Bidder's Statement of Financial Responsibility Technical Ability and Experience**
5. **Insurance Certification**
6. **Non-Collusion Declaration of Contractor**
7. **Bidder's Statement of Subcontractors – Part I (The Contractor and all Subcontractors shall have valid, current and active Contractor's licenses for the classification of work performed, prior to submittal of Bid, during Award and throughout the Contract.)**

The lowest and second lowest ranked project Bidders shall submit the following forms, fully completed, to the Public Works Department, City of Salinas, within 5 working days after Bid opening date and/or when the lowest responsible Bidder is known. The Documents to be completed and submitted are the following:

8. **Bidder's Statement of Subcontractors – Part II**
9. **Non-Collusion Declaration of Subcontractor**
10. **Bidder's Statement of Good Faith Effort for Local Hire**
11. **Bidder's List for the City of Salinas Public Works Department. The Prime Contractor shall submit original(s). All Subcontractor(s) shall submit original(s) or faxed copy (copies)**

Failure to comply with these requirements may result in the forfeiture of the Bidder's rank in the Bid process.

In lieu of conflicting portions of "Section 2-1.05 Proposal Forms" of the Standard Specifications, the following shall apply:

Only Bids composed of the above listed items shall be considered for Award. Any and all Addenda to the Plans and Specifications shall be issued electronically on-line through the PlanetBids Vendor Portal website and ONLY to Bidders who are registered Prospective Bidders for this project on-line at the PlanetBids Vendor Portal website as having received a set of Plans and Specifications. The City shall not be responsible for issuance of said Addenda to non-registered Plan holders.

The successful Bidder and all Subcontractors must have a valid City of Salinas business license before the commencement of work.

All wage scales shall be in accordance with applicable determinations made by the Director of the DIR of the State of California, as provided by Article 2, Chapter 1, Division 2, Part 7 of the Labor Code of the State of California, commencing with Section 1771. In accordance with Section 1773.2 of the said Labor Code, copies of the aforesaid determinations of the Director of the DIR are available on the website address <http://www.dir.ca.gov/OPRL/DPreWageDetermination.htm>. **It shall be mandatory for the Contractor to whom the Contract is awarded to pay not less than the applicable prevailing wage rate to all workers employed for the execution of the Contract and employ apprentices pursuant to Section 1777.5 of the California Labor Code.**

**PART A –
BID CONTRACT DOCUMENTS**

**CONTRACT DOCUMENTS TO BE SUBMITTED WITH BID ON
BID OPENING DATE**

Invitation to Bid Addendum No.1

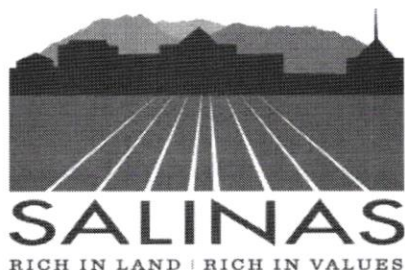

Landscape Services for Monte Bella Maintenance District

*Richard J.
5/25/21*

DATE: May 19, 2021
TO: Potential Responders to Invitation to Bid
FROM: David Lewellen, District Maintenance /Forestry Manager
RE: City of Salinas Invitation to Bid for Landscape Services for Monte Bella
Maintenance District

NOTICE TO ALL POTENTIAL RESPONDENTS, The Bid Proposal Package (“Bids”) is modified as set forth in this Addendum. The original BID documents and any previously issued addenda remain in full force and effect, except as modified by this Addendum, which is hereby incorporated and made part of the BID. Respondent shall take this Addendum into consideration when preparing and submitting Respondent’s Proposal.

Submittal Deadline

This Addendum does not change the Proposal submission deadline of May 25, 2021 at 2:00 p.m. Pacific Standard Time (“PST”).

Manner of Submission

Electronic proposals will be accepted and are preferred. All electronic proposals shall be submitted by May 25, 2021 at 2:00 p.m. PST.

It is the Bidder’s responsibility to ensure that said BID shall be fully uploaded / transmitted via the PlanetBids website, prior to the aforementioned designated date and time. The City will not be accepting paper bids.

Questions and Answers

The following Addendum will address three items:

First: Question about The Monte Bella District.

1. What are the previous bid results/engineer's estimate for the district?

The previous amount for the district was \$40,680.00/year \$3,390.00/monthly.

Second: How will the public be able to attend/participate to hear the results of the Bid process?

Bids will be opened and entered into the record via a public Zoom meeting. Below are the instructions for accessing Zoom.

Join Zoom Meeting

<https://zoom.us/j/97991075361?pwd=cFFPSXEvQU92WW9CNTRVV3VxTFdOdz09>

Meeting ID: 979 9107 5361

Passcode: 890132

One tap mobile

+16699006833,,97991075361#,,,,*890132# US (San Jose)

+13462487799,,97991075361#,,,,*890132# US (Houston)

Dial by your location

+1 669 900 6833 US (San Jose)

+1 346 248 7799 US (Houston)

+1 253 215 8782 US (Tacoma)

+1 301 715 8592 US (Washington DC)

+1 312 626 6799 US (Chicago)

+1 929 436 2866 US (New York)

Meeting ID: 979 9107 5361

Passcode: 890132

Find your local number: <https://zoom.us/u/aeIyP7L4Px>

Three: **NOTICE TO BIDDERS**

Notice is hereby given that the City of Salinas, County of Monterey, State of California (hereinafter referred to as "City"), hereby invites sealed Bid Proposals for the following work to be completed according to Plans and Specifications on file, adopted therefore, to wit:

LANDSCAPE SERVICES FOR MONTE BELLA MAINTENANCE DISTRICT

A scanned copy of the Bid Proposal Package ("Bids") for the above-mentioned work shall be submitted electronically via the PlanetBids website until **2:00 p.m.** Pacific Standard Time on May 25th 2021, at which time or thereafter said bids will be electronically opened and available online. A link to the meeting will be made available through PlanetBids. **It is the Bidder's responsibility to ensure that said Bid shall be fully uploaded / transmitted via the PlanetBids website, prior to the aforementioned designated date and time. The City will not be accepting paper bids.**

In addition to electronic Bid submittals, 2 sealed original hard copies (to be used for verification) must also be sent via courier service, mailed, or delivered when the lowest apparent bidder is known. Hardcopies must be received within 5 working days after Bid opening date: Complete Proposal signed and dated; Signed Addendum, if any; Bid Bond; Bidder's Statement of Financial Responsibility Technical Ability and Experience; Insurance Certification; Non-Collusion Declaration of Contractor; and Bidder's Statement of Subcontractors – Part I. **Failure to comply with these requirements may result in the forfeiture of the Bidder's rank in the Bid process.**

Please mail hard copy of bid to the following address:

City of Salinas
Public Works Department
Environmental & Maintenance Services Division
426 Work St.
Salinas, CA 93901
ATTN: Dave Lewellen



SMITH & ENRIGHT — Landscaping, Inc. —

BID BOND FOR :

Landscape Services for
Monte Bella Maintenance District

THIS CHECK IS PROTECTED WITH A VOID PANTOGRAPH - OTHER SECURITY FEATURES DETAILED ON BACK.

PINNACLE BANK

CASHIER'S CHECK

300102

18181 Butterfield Blvd, Suite 135
Morgan Hill, CA 95037

NOTICE TO CUSTOMERS
THE PURCHASE OF AN INDEMNITY BOND MAY BE REQUIRED
BEFORE ANY CASHIER'S CHECK OF THIS BANK WILL BE
REPLACED OR REFUNDED IN THE EVENT IT IS LOST,
MISPLACED OR STOLEN.

90-4434
1211

DATE May 24, 2021

REMITTER Richard Enright

\$***15,264.00**

PAY Fifteen Thousand Two Hundred Sixty Four Dollars AND 00/100

TO THE ORDER OF City Of Salinas

AUTHORIZED SIGNATURE

PURPOSE Bid Bond Monte Bella

⑈ 300 10 2⑈

⑆ 121144340⑆

⑈ 10 29900 17⑈

Office: 831-758-6766

Email: info@smithenright.com

Fax: 831-758-5589

540 Work St, Ste. C, Salinas, CA 93901

SmithEnright.com

PROPOSAL

FOR

LANDSCAPE SERVICES FOR MONTE BELLA MAINTENANCE DISTRICT

SALINAS, CALIFORNIA

FROM:

NAME OF BIDDER: Smith & Enright Landscaping, Inc

BUSINESS ADDRESS: 540 Work St Suite C

(Street Address)

CITY: Salinas

STATE: California

ZIP: 93901

PHONE: 831-758-6766

RESIDENCE ADDRESS: 660 San Mateo

CITY: Salinas

STATE: California

ZIP: 93901

PHONE: 831-758-6766

Honorable Mayor of City Council
City of Salinas
Salinas, California

Gentlemen/Ladies:

Pursuant to the foregoing Notice to Bidders, the undersigned hereby proposes and binds himself/herself on award by the City Council under this Proposal to execute in accordance with such award, a Contract with necessary bonds of which this Proposal, the Notice to Bidders, and the Plans and the Specifications adopted *{Date Adopted By Council}*, shall be a part, to furnish any and all required labor, material, and services for performing and completing the work set forth in the said Specifications and shown on the Plans accompanying them, within the time hereinafter set forth and at the prices named in this Proposal as follows:

✓By checking this box, the Bidder hereby affirms it meets the requirements set forth under Chapter 12 Article III A-Local Purchasing Preference. All Local Contractors must have a Declaration of Local Business Enterprise form filed with the City of Salinas Finance Department. Refer to link for requirements <https://www.cityofsalinas.org/our-city-services/finance/bid-requests-rfps> and Declaration of Local Business Form.

LANDSCAPE SERVICES FOR MONTE BELLA MAINTENANCE DISTRICT

The work shall involve the furnishing of all labor, material, equipment, and incidentals to perform the Landscape Maintenance in the Landscape and Lighting Districts in accordance with the Plan, Specifications and Special Provisions. The maintenance district is as shown on the location map and described in detail in Section 9:

PROPOSAL ITEMS:

Base Bid

Item #1: 24 Months Landscape Maintenance for the Monte Bella Area District

\$3,995.00 per month

Total for Base Bid: \$ \$3,995.00 Per month

Additive Alternate#1

Note: The estimated hours and dollar amounts requested below do not represent what the contractor may or may not earn through unscheduled work.

Item #2	80 hours x General Gardening Crew rate	\$ <u>3,840.00</u>
Item #3	50 hours x Specialty Irrigation Crew rate	\$ <u>3,500.00</u>
Item #4	\$7,000 x Percentage Markup	\$ <u>7,777.00</u>

Total for Additive Alternate #1 \$ 15,117.00

Total for Base Bid plus Additive Alternate #1: \$ 19,112.00

The Additive Alternate total will be added to the annual contract fee for accessing low bid only. The hourly crew rate quoted shall include all Contractor costs for wages, insurance, overhead and equipment. Fees for materials shall include Contractors lowest / best purchase price, plus tax and markups.

Extra Work Items

Item #5: **GENERAL GARDENING CREW RATE** (Service based on a two-person crew). Provide general gardening services as required (i.e. sprinkler replacement, special cleanups)

\$ 50 Total Hourly

Item #6: **SPECIALTY IRRIGATION CREW RATE** (Service based on a two-person crew, Irrigation Technician and Helper). Provide irrigation repair for valves, solenoids, controllers, lateral and main line breaks.

Technician \$ 70 _____ Total
 Hourly Helper Rate \$ 60 _____ Total
 Hourly

Item #7: PLANT PURCHASE AND INSTALLATION PRICE THAT MEET CITY STANDARDS

1 gallon \$ 20 _____ Total
 2 gallon \$ 30 _____ Total
 5 gallon \$ 50 _____ Total
 10 gallon \$ 100 _____ Total
 15 gallon \$ 220 _____ Total
 24-inch box tree \$ 520 _____ Total

*maintenance/replacement costs only,
 if new construction project, different prevailing
 wage classification applies

Item #8: PERCENT OF MARKUP ON MATERIALS - Percentage increase over the best/lowest cost, including Contractor discounts, paid by Contractor for materials approved for replacement or installation 10 %

Item #9: TREE TRIMMING

*w/o knowing measurements it is difficult to give accurate price

DBH price for removal \$ 95.00 per hour _____ Total

DBH price for trimming (Structural pruning to maintain strength and shape)

\$ 95.00 per hour _____ Total

Stump Grinding to a depth of three feet including grubbing and root removal

\$ 95.00 per hour _____ Total

Item #10: ADDITIONAL AREAS TO BE ADDED DURING CONTRACT PERIOD Landscaping and additional areas may be added to maintenance site. Addition of said areas would be after plant establishment periods, to include original landscape contractor warranties. Prices shall include both labor and materials.

\$ 2,000.00 _____ Total Monthly Price per Acre

NOTE: For Bid package to be VALID: (1) the Bidder must submit Bid for Base Bid and Bid items; (2) the Bidder must submit all completely executed and signed City of Salinas forms; and (3) the Contractor and all Subcontractors shall have valid, current and active Contractor's license(s) for the classification(s) of work performed and be registered with the DIR pursuant to Labor Code section 1725.5, and the license(s) must be valid prior to award of Contract and throughout the Contract as approved by Council.

It is expressly understood and agreed that this Bid shall have the following documents completed, all of which are incorporated into and made a part hereof. **The following information shall be submitted with the Bid Proposal on the Bid Opening Date:**

1. Complete Proposal signed and dated
2. Signed Addendum, if any
3. Bid Bond
4. Bidder's Statement of Financial Responsibility Technical Ability and Experience
5. Insurance Certification
6. Non-Collusion Declaration of Contractor
7. Bidder's Statement of Subcontractors – Part I (The Contractor and all Subcontractors shall have valid, current, and active Contractor's licenses for the classification of work performed, prior to submittal of Bid, during Award, and throughout the Contract.)

The lowest and second lowest ranked project Bidders shall submit the following forms, fully completed, to the Public Works Department, City of Salinas, within 5 working days after Bid opening date and/or when the lowest responsible Bidder is known. The Documents to be completed and submitted are the following:

8. Bidder's Statement of Subcontractors – Part II
9. Non-Collusion Declaration of Subcontractor
10. Bidder's Statement of Good Faith Effort for Local Hire
11. Bidder's List for the City of Salinas Public Works Department. The Prime Contractor shall submit original(s). All Subcontractor(s) shall submit original (s) or faxed copy (copies)

Failure to comply with these requirements may result in the forfeiture of the Bidder's rank in the Bid process.

The undersigned understands that the quantities given are approximate only, being given as a basis for the comparison of Bids, and the City of Salinas does not, expressly or by implication, agree that the actual amount of work shall correspond therewith, but reserves the right to increase or decrease the amount of any portion of the work, or to omit portions of the work, as may be deemed necessary or advisable by the City Engineer without claim for damage or loss of anticipated profit and that payment shall be made only on the basis of the actual quantities of work performed.

The City reserves the right to award the contract to a responsible, responsive Bidder with the lowest possible bid for each amount noted in the “Total for Base Contract #” amount. The City further reserves the right to award or reject any or all proposals depending on available funding.

Except as may otherwise be provided herein, all work to be done under this Contract shall conform to the applicable requirements of the DESIGN STANDARDS, STANDARD SPECIFICATIONS AND STANDARD PLANS, 2008 Edition, City of Salinas Public Works Department, herein referred to as the “Standard Specifications”.

In addition to the Subcontractors required to be listed in conformance with the Standard Specifications, **the Contractor shall submit: name, address, DIR Public Works Registrations number, Contractor’s license number including State/expiration date and the portion of the work that shall be done by each Subcontractor. Contractor shall comply with all requirements of the City of Salinas Local Hiring Preference Ordinance 2330, Salinas City Code Chapter 12, Article IV, with respect to person(s) hired by the Contractor, and to all persons hired by the Contractor’s Subcontractor(s). All prospective Contractors may use the website <https://www2.cslb.ca.gov/OnlineServices/CheckLicenseII/CheckLicense.aspx> to check each Subcontractor’s license status and the DIR’s Contractor Registration searchable database <https://efiling.dir.ca.gov/PWCR/Search.action> to verify each Subcontractor’s registration status.**

The Bidder shall submit the list of Subcontractor(s) with the Proposal. Use the form supplied in the Contract documents. If no such list is submitted, it shall be assumed that the Contractor shall do all the work herein specified.

The successful Bidder and all Subcontractors must have a valid City of Salinas business license before the commencement of work.

The undersigned understands that the quantities given are approximate only, being given as a basis for the comparison of Bids, and the City of Salinas does not, expressly or by implication, agree that the actual amount of work shall correspond therewith, but reserves the right to increase or decrease the amount of any portion of the work or to omit portions of the work as may be deemed necessary or advisable by the City Engineer without claim for damage or loss of anticipated profit and that payment shall be made only on the basis of the actual quantities of work performed.

The undersigned further agrees that all work to be done under this Contract shall be done in accordance with the provisions of that certain form of Agreement attached hereto and hereby made a part of these Specifications.

The undersigned agrees, if awarded the Contract, that there shall be paid by the undersigned and by all Subcontractors under him/her, to all laborers, workmen and mechanics employed in the execution of such Contract or any Subcontract thereunder, not less than the general prevailing rate of per diem wages and rates for overtime and legal holidays in the locality in which the work is to be performed, as ascertained and determined, pursuant to the state statute thereto applicable, by the City Council, the schedule thereof being set forth in the advertisement for Bids and in the Specifications for said work.

All questions about the meaning or intent of the Contract documents shall be submitted to the City of Salinas through the project page on the Planet Bids website. Replies shall be issued by Addenda electronically on-

line through the PlanetBids Vendor Portal website and ONLY to Bidders who are registered Prospective Bidders for this project. **QUESTIONS RECEIVED LESS THAN 10 CALENDAR DAYS PRIOR TO THE DATE OF THE OPENING BIDS SHALL NOT BE ANSWERED.** Only questions answered by Addenda shall be binding. Oral and other interpretations or clarifications shall be without legal effect.

Any and all Addenda to the Plans and/or Specifications shall be signed and attached hereto this Proposal.

For any money earned by the Undersigned and withheld by the City of Salinas, to insure the performance of the Contract, the Undersigned may, at his/her request and expense, substitute securities equivalent to the amount withheld in the form and manner and subject to the conditions provided in Section 22300 of the Public Contracts Code of the State of California.

Licensed in accordance with an act providing for the registration of Contractors:

License No.: C-27 757700 DIR Registration No.: #1000011127

Expiration Date: 01/31/2023 DIR Reg. Exp. Date: 06/30/2021

(If Bidder is a joint venture, each member must specify license number, expiration date and statement regarding representations made.)

(If an individual, so state. If a firm or co-partnership, state the firm name and give the names of all individuals; co-partners composing the firm. If a corporation, state legal names of corporation, also names of President, Secretary, Treasurer, and Manager thereof.)

Smith & Enright Landscaping, Inc

540 Work St Suite C

Salinas, CA 93901

Business Address

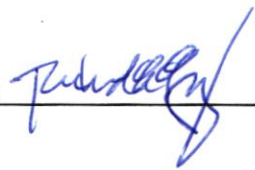
Signature of Bidder: 

(Signature in blue ink)

Dated: May 24th, 2021

NON-COLLUSION DECLARATION OF CONTRACTOR

(This form must be completed and submitted with this Bid)

State of California, }
County of Monterey, }SS

Richard Enright, being first duly sworn, deposes and says that:

I am the (*owner, partner, officer, representative, or agent*) Officer of Smith & Enright,
the party making the foregoing Bid:

The Bid is not made in the interest of or on behalf of any undisclosed person, partnership, company, association, organization, or corporation. The Bid is genuine and not collusive or sham. The Bidder has not, directly or indirectly, induced or solicited any other bidder to put in a false or sham Bid. The Bidder has not, directly or indirectly, colluded, conspired, connived, or agreed with any bidder or anyone else to put in a sham Bid or to refrain from bidding. The Bidder has not in any manner, directly or indirectly, sought by agreement, communication, or conference with anyone to fix the bid price of the Bidder or any other bidder, or to fix any overhead, profit, or cost element of the bid price or of that of any other bidder. All statements contained in the Bid are true. The Bidder has not, directly or indirectly, submitted his or her Bid price or any breakdown thereof or the contents thereof or divulged information or data relative thereto, to any corporation, partnership, company, association, organization, bid depository, or to any member or agent thereof, to effectuate a collusive or sham Bid, and has not paid, and will not pay, any person or entity for such purpose.

Any person executing this declaration on behalf of a Bidder that is a corporation, partnership, joint venture, limited liability company, limited liability partnership, or any other entity, hereby represents that he or she has full power to execute, and does execute, this declaration on behalf of the Bidder.

I declare under penalty of perjury under the laws of the State of California that the foregoing is true and correct and that this declaration is executed on 5/24/21 [date], at Salinas [city], CA [state].

Signed 

Vice-President

Title

Attach Notary Acknowledgment if signature is not the same as the Proposal signature(s)

CALIFORNIA ALL-PURPOSE CERTIFICATE OF ACKNOWLEDGMENT

A notary public or other office completing this certificate verifies only the identity of the individual who signed the document to which this certificate is attached, and not the truthfulness, accuracy, or validity of that document.

State of California

County of Monterey

On 5-24-2021 before me, Enrique Méndez Méndez, Notary Public
(Here insert name and title of the officer)

personally appeared Richard Fought

who proved to me on the basis of satisfactory evidence to be the person(s) whose name(s) is/are subscribed to the within instrument and acknowledged to me that he/~~she~~they executed the same in his/~~her~~their authorized capacity(ies), and that by his/~~her~~their signature(s) on the instrument the person(s), or the entity upon behalf of which the person(s) acted, executed the instrument.

I certify under PENALTY OF PERJURY under the laws of the State of California that the foregoing paragraph is true and correct.

WITNESS my hand and official seal.

Enrique Méndez Méndez
Notary Public Signature

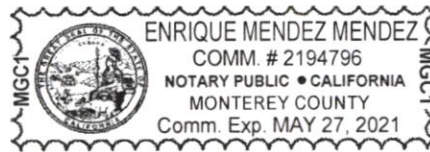

(Notary Public Seal)

ADDITIONAL OPTIONAL INFORMATION

DESCRIPTION OF THE ATTACHED DOCUMENT

Non-Collusion Declaration

(Title or description of attached document)

of Contract

(Title or description of attached document continued)

Number of Pages 1

Document Date 5-24-2021

CAPACITY CLAIMED BY THE SIGNER

- Individual(s)
 Corporate Officer

(Title)

- Partner(s)
 Attorney-in-Fact
 Trustee(s)
 Other

INSTRUCTIONS FOR COMPLETING THIS FORM

This form complies with current California statutes regarding notary wording and, if needed, should be completed and attached to the document. Acknowledgments from other states may be completed for documents being sent to that state so long as the wording does not require the California notary to violate California notary law.

- State and County information must be the State and County where the document signer(s) personally appeared before the notary public for acknowledgment.
- Date of notarization must be the date that the signer(s) personally appeared which must also be the same date the acknowledgment is completed.
- The notary public must print his or her name as it appears within his or her commission followed by a comma and then your title (notary public)
- Print the name(s) of document signer(s) who personally appear at the time of notarization
- Indicate the correct singular or plural forms by crossing off incorrect forms (i.e. ~~he/she/they~~ is/are) or circling the correct forms. Failure to correctly indicate this information may lead to rejection of document recording.
- The notary seal impression must be clear and photographically reproducible. Impression must not cover text or lines. If seal impression smudges, re-seal if a sufficient area permits, otherwise complete a different acknowledgment form.
- Signature of the notary public must match the signature on file with the office of the county clerk.
 - ❖ Additional information is not required but could help to ensure this acknowledgment is not misused or attached to a different document.
 - ❖ Indicate title or type of attached document, number of pages and date.
 - ❖ Indicate the capacity claimed by the signer. If the claimed capacity is a corporate officer, indicate the title (i.e. CEO, CFO, Secretary)
- Securely attach this document to the signed document with a staple.



INSURANCE CERTIFICATION

(This certification shall be completed and submitted with the proposed Bid)

By signing below, I hereby certify that Smith & Enright Landscaping, Inc
(Insert company name)

is currently insured by an insurance company that is an **“Authorized”** carrier by the Insurance Commissioner of the California State Department of Insurance to transact the business of insurance in the State of California, and shall be written by insurers with a current A.M. Best Rating of “A-Class VIII” or better, and a financial size of “VII” or greater. Said insurance will expire on 08/10/2021.

I further hereby certify that, as the signer of this Bid Proposal, I have read and understand the City’s insurance requirements as described in the Section entitled “Insurance Requirements” within these Specifications and that proof of insurance shall be required before the Public Works Services Contract is recommended for Award. Such proof shall be provided on an ISO Accord 25(s) form and an endorsement naming the City of Salinas as additionally insured is on the ISO CG 20 10 11 85 form or any other comparable endorsement, which does not further limit coverage, and which may be approved and accepted by the City Attorney.

Richard Enright

(Print Name)

Signature of Bidder:

(Signature)

May 24, 2021

(Date)

Type text here

Attach Notary Acknowledgment if signature is not the same as the Proposal signature(s)

**CONTRACT DOCUMENTS TO BE SUBMITTED TO THE CITY
WITHIN 5 WORKING DAYS AFTER BID OPENING DATE**

BIDDER'S STATEMENT OF SUBCONTRACTORS – PART II

(This information may be submitted with your Proposal. If it is not, and you are the apparent low Bidder or the second low Bidder, it shall be submitted and received by the Public Works Department no later than 5 working days after Bid opening date and/or when the lowest responsible Bidder is known.)

List all Subcontractors performing work on site, including 1st tiered Subcontractors under one-half of one percent (0.5%) of the total contract bid or \$10,000.

The undersigned submits herewith a list of Subcontractors whom he/she proposes to employ on the work, with the proper firm name and business address of each.

If no list submitted, it shall be assumed that the Contractor shall do all the work as specified.

The Contractor and all Subcontractors shall have valid Contractor's licenses for the classification of work performed, at time of award of Contract, and throughout the Contract. **All prospective Contractors may use the website <https://www2.cslb.ca.gov/OnlineServices/CheckLicenseII/CheckLicense.aspx> to check each Subcontractor's license status and expiration dates.**

The Contractor and all Subcontractors must possess and maintain a current Public Works Contractor registration with the Department of Industrial Relations (DIR), at the time Bid is submitted, and throughout the Contract. **All prospective Contractors may search the DIR's Public Works Contractor Registration searchable database <https://www.dir.ca.gov/public-works/publicworks.html> to verify each Subcontractor's registration status.**

Subcontractor: Silvino Sanchez Landscaping License No. / State: 1009392 CA
DIR Registration No.: 1000726545 DIR Registration Expiration Date: 06/30/21
Address: 328 Roberts Ave City: Seaside Zip: 93955
Description of Work: Landscaping and Tree Trimming
Telephone: 831-620-5446 Fax: _____ Email Address: yesanchez8822@gmail.com
Bid Item No. & % of each: Sect 11 N. Tree Work 10% Bid # 9
*Business License No. FINBL21-00148

Subcontractor: Hemi's Landscaping and Concrete, Inc License No. / State: 903795 CA
DIR Registration No.: 1000020090 DIR Registration Expiration Date: 06/30/23
Address: 446 Boronda Rd City: Salinas Zip: 93901
Description of Work: Landscaping & Concrete
Telephone: 831-594-6182 Fax: _____ Email Address: hemi0425@yahoo.com
Bid Item No. & % of each: Sect 11. Landscaping 10% Bid # 1.
*Business License No. 63684

Contractor shall provide all Subcontractor information requested above.

Subcontractor: _____ **License No. / State:** _____

DIR Registration No.: _____ **DIR Registration Expiration Date:** _____

Address: _____ City: _____ Zip: _____

Description of Work: _____

Telephone: _____ Fax: _____ Email Address: _____

Bid Item No. & % of each: _____

***Business License No.** _____

Subcontractor: _____ **License No. / State:** _____

DIR Registration No.: _____ **DIR Registration Expiration Date:** _____

Address: _____ City: _____ Zip: _____

Description of Work: _____

Telephone: _____ Fax: _____ Email Address: _____

Bid Item No. & % of each: _____

***Business License No.** _____

Subcontractor: _____ **License No. / State:** _____

DIR Registration No.: _____ **DIR Registration Expiration Date:** _____

Address: _____ City: _____ Zip: _____

Description of Work: _____

Telephone: _____ Fax: _____ Email Address: _____

Bid Item No. & % of each: _____

***Business License No.** _____

Subcontractor: _____ **License No. / State:** _____

DIR Registration No.: _____ **DIR Registration Expiration Date:** _____

Address: _____ City: _____ Zip: _____

Description of Work: _____

Telephone: _____ Fax: _____ Email Address: _____

Bid Item No. & % of each: _____

***Business License No.** _____

Contractor shall provide all Subcontractor information requested above.

SIGNED: _____ *[Handwritten Signature]* _____ *5.27.21*
(Signature) (Date)

Attach Notary Acknowledgment if signature is not the same as the Proposal signature(s)

**City of Salinas Business License shall be acquired before commencement of work.*

Subcontractor: _____ **License No. / State:** _____

DIR Registration No.: _____ **DIR Registration Expiration Date:** _____

Address: _____ City: _____ Zip: _____

Description of Work: _____

Telephone: _____ Fax: _____ Email Address: _____

Bid Item No. & % of each: _____

***Business License No.** _____

Subcontractor: _____ **License No. / State:** _____

DIR Registration No.: _____ **DIR Registration Expiration Date:** _____

Address: _____ City: _____ Zip: _____

Description of Work: _____

Telephone: _____ Fax: _____ Email Address: _____

Bid Item No. & % of each: _____

***Business License No.** _____

Subcontractor: _____ **License No. / State:** _____

DIR Registration No.: _____ **DIR Registration Expiration Date:** _____

Address: _____ City: _____ Zip: _____

Description of Work: _____

Telephone: _____ Fax: _____ Email Address: _____

Bid Item No. & % of each: _____

***Business License No.** _____

Subcontractor: _____ **License No. / State:** _____

DIR Registration No.: _____ **DIR Registration Expiration Date:** _____

Address: _____ City: _____ Zip: _____

Description of Work: _____

Telephone: _____ Fax: _____ Email Address: _____

Bid Item No. & % of each: _____

***Business License No.** _____

Contractor shall provide all Subcontractor information requested above.

SIGNED: 
(Signature)

5-31-21
(Date)

Attach Notary Acknowledgment if signature is not the same as the Proposal signature(s)

*City of Salinas Business License shall be acquired before commencement of work.

NON-COLLUSION DECLARATION OF SUBCONTRACTOR

(This form must be completed and submitted with this Bid)

State of California, }SS
County of Monterey,

David Sanchez, being first duly sworn, deposes and says that:

He/she is (*owner, partner, officer, representative, or agent*) of Silvino Sanchez Landscaping, hereinafter referred to as the "Subcontractor";

He/she is fully informed respecting the preparation and contents of the Subcontractor's Proposal submitted by the Subcontractor to Smith & Enright Landscaping, Inc, the Contractor for certain work in connection with the City of Salinas (City or County and State);

The proposal is not made in the interest of or on behalf of any undisclosed person, partnership, company, association, organization, or corporation. The proposal is genuine and not collusive or sham. The Subcontractor has not, directly or indirectly, induced or solicited any other bidder to put in a false or sham Bid. The Subcontractor has not, directly or indirectly, colluded, conspired, connived, or agreed with any bidder or anyone else to put in a sham Bid, or to refrain from bidding. The Subcontractor has not in any manner, directly or indirectly, sought by agreement, communication, or conference with anyone to fix the bid price of the Bidder or any other bidder, or to fix any overhead, profit, or cost element of the bid price or of that of any other bidder. All statements contained in the proposal are true. The Subcontractor has not, directly or indirectly, submitted his or her proposal price or any breakdown thereof, or the contents thereof or divulged information or data relative thereto, to any corporation, partnership, company, association, organization, bid depository, or to any member or agent thereof, to effectuate a collusive or sham Bid, and has not paid, and will not pay, any person or entity for such purpose.

Any person executing this declaration on behalf of a Subcontractor that is a corporation, partnership, joint venture, limited liability company, limited liability partnership, or any other entity, hereby represents that he or she has full power to execute, and does execute, this declaration on behalf of the Subcontractor.

I declare under penalty of perjury under the laws of the State of California that the foregoing is true and correct and that this declaration is executed on 06/01/21 [date], at Salinas [city], CA [state].

Signed

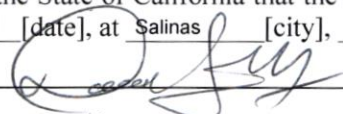
Representative
Title

Attach Notary Acknowledgment

CALIFORNIA ALL-PURPOSE CERTIFICATE OF ACKNOWLEDGMENT

A notary public or other officer completing this certificate verifies only the identity of the individual who signed the document to which this certificate is attached, and not the truthfulness, accuracy, or validity of that document

State of California
County of Monterey

On June 1, 2021 before me, April Wilson, Notary Public
personally appeared David Sanchez

who proved to me on the basis of satisfactory evidence to be the person(s) whose name(s) is/are subscribed to the within instrument and acknowledged to me that he/she/they executed the same in his/her/their authorized capacity(ies), and that by his/her/their signature(s) on the instrument the person(s), or the entity upon behalf of which the person(s) acted, executed the instrument.



I certify under PENALTY OF PERJURY under the laws of the State of California that the foregoing paragraph is true and correct.

WITNESS my hand and official seal.

NOTARY SEAL

Signature April Wilson
Signature of Notary Public

ADDITIONAL OPTIONAL INFORMATION

Title or Description of attached document: Non-Confusion Declaration
of Subcontractor

Document Date: June 1, 2021 Number of Pages: one

Capacity(ies) Claimed by Signer

Signer's Name: _____

- Individual
- Corporate Officer
- Partner
- Attorney-in-Fact
- Trustee
- Other: _____

Signer is representing _____

Capacity(ies) Claimed by Signer

Signer's Name: _____

- Individual
- Corporate Officer
- Partner
- Attorney-in-Fact
- Trustee
- Other: _____

Signer is representing _____

NON-COLLUSION DECLARATION OF SUBCONTRACTOR

(This form must be completed and submitted with this Bid)

State of California, }SS
County of Monterey,

Isidoro Hernandez Munoz, being first duly sworn, deposes and says that:

He/she is (owner, partner, officer, representative, or agent) of Hemi's Landscaping and Concrete Inc, hereinafter referred to as the "Subcontractor";

He/she is fully informed respecting the preparation and contents of the Subcontractor's Proposal submitted by the Subcontractor to Smith & Enright Landscaping, Inc, the Contractor for certain work in connection with the City of Salinas (City or County and State);

The proposal is not made in the interest of or on behalf of any undisclosed person, partnership, company, association, organization, or corporation. The proposal is genuine and not collusive or sham. The Subcontractor has not, directly or indirectly, induced or solicited any other bidder to put in a false or sham Bid. The Subcontractor has not, directly or indirectly, colluded, conspired, connived, or agreed with any bidder or anyone else to put in a sham Bid, or to refrain from bidding. The Subcontractor has not in any manner, directly or indirectly, sought by agreement, communication, or conference with anyone to fix the bid price of the Bidder or any other bidder, or to fix any overhead, profit, or cost element of the bid price or of that of any other bidder. All statements contained in the proposal are true. The Subcontractor has not, directly or indirectly, submitted his or her proposal price or any breakdown thereof, or the contents thereof or divulged information or data relative thereto, to any corporation, partnership, company, association, organization, bid depository, or to any member or agent thereof, to effectuate a collusive or sham Bid, and has not paid, and will not pay, any person or entity for such purpose.

Any person executing this declaration on behalf of a Subcontractor that is a corporation, partnership, joint venture, limited liability company, limited liability partnership, or any other entity, hereby represents that he or she has full power to execute, and does execute, this declaration on behalf of the Subcontractor.

I declare under penalty of perjury under the laws of the State of California that the foregoing is true and correct and that this declaration is executed on _____ [date], at _____ [city], _____ [state].

Signed Isidoro Hernandez Munoz
PRESIDENT
Title

Attach Notary Acknowledgment

ACKNOWLEDGMENT

A notary public or other officer completing this certificate verifies only the identity of the individual who signed the document to which this certificate is attached, and not the truthfulness, accuracy, or validity of that document.

State of California
County of MONTEREY)

On JUNE 1ST, 2021 before me, LILI M. ANARIBA DE PAZ-NOTARY PUBLIC
(insert name and title of the officer)

personally appeared ISIDRO HERNANDEZ MURILLO*****,
who proved to me on the basis of satisfactory evidence to be the person(s) whose name(s) is/are subscribed to the within instrument and acknowledged to me that he/she/they executed the same in his/her/their authorized capacity(ies), and that by his/her/their signature(s) on the instrument the person(s), or the entity upon behalf of which the person(s) acted, executed the instrument.

I certify under PENALTY OF PERJURY under the laws of the State of California that the foregoing paragraph is true and correct.

WITNESS my hand and official seal.

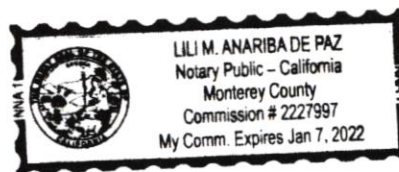

Signature *Lili M. Anariba de Paz* (Seal)

STATEMENT OF GOOD FAITH EFFORT FOR LOCAL HIRE

For

**The City of Salinas
Public Works Department**

(This information may be submitted with your proposal. If it is not, and you are the apparent low Bidder or the second low Bidder, it must be submitted and received by the Public Works Department no later than 5 working days after Bid opening date.)

In conformance with Article IV to Chapter 12 of the Salinas Municipal Code, each Contractor and Subcontractor shall complete and submit this **Statement of Good Faith Effort**.

Project Title: Monte Bella Maintenance District

Contractor (or Subcontractor): Smith & Enright Landscaping, Inc

Address: 540 Work St Suite C

City: Salinas State: CA Zip: 93901

Contractor (or Subcontractor) estimates that fifty percent (50%) or more of its workforce, for this project, meets the local hire requirements for this contract:

Yes No **If "No", the apparent successful Bidder (low Bidder) and the second low Bidder shall complete and submit the following form to the office at which bids were received so the information is received by the Department no later than 5 working days after bid opening:**

Name and Address of Local Recruitment Source	Date of Recruit. Contact	Person Contacted and Phone #	Recruitment For: Trade & Classification	Number of Referrals Requested	# of Local Hires as Result of Contact	Names and address of Local Hire (2) as a Result of Contact

I certify that the information contained in this form is true and correct, to the best of my knowledge, (Please sign all pages.) *(Submitted under penalty of perjury, Salinas City Code, Section 12-31.)*

Selena Herrin
Name (Please Print)
General Manager
Title or Position (Please Print)
06/07/21
Date

Attach Notary Acknowledgment

Page ___ of ___

CALIFORNIA ALL-PURPOSE CERTIFICATE OF ACKNOWLEDGMENT

A notary public or other officer completing this certificate verifies only the identity of the individual who signed the document to which this certificate is attached, and not the truthfulness, accuracy, or validity of that document

State of California
County of Monterey

On June 7, 2021 before me, Vanessa Paradise, Notary Public
personally appeared Selena Hessin

who proved to me on the basis of satisfactory evidence to be the person(s) whose name(s) is/are subscribed to the within instrument and acknowledged to me that he/she/they executed the same in his/her/their authorized capacity(ies), and that by his/her/their signature(s) on the instrument the person(s), or the entity upon behalf of which the person(s) acted, executed the instrument.



NOTARY SEAL

I certify under PENALTY OF PERJURY under the laws of the State of California that the foregoing paragraph is true and correct.

WITNESS my hand and official seal.

Signature

Van Paradise

Signature of Notary Public

ADDITIONAL OPTIONAL INFORMATION

Title or Description of attached document: Statement of Good Faith
Effect for Local Hire

Document Date: June 7, 2021 Number of Pages: - ONE -

Capacity(ies) Claimed by Signer

Signer's Name: _____

- Individual
- Corporate Officer
- Partner
- Attorney-in-Fact
- Trustee
- Other: _____

Signer is representing _____

Capacity(ies) Claimed by Signer

Signer's Name: _____

- Individual
- Corporate Officer
- Partner
- Attorney-in-Fact
- Trustee
- Other: _____

Signer is representing _____

STATEMENT OF GOOD FAITH EFFORT FOR LOCAL HIRE

For

**The City of Salinas
Public Works Department**

(This information may be submitted with your proposal. If it is not, and you are the apparent low Bidder or the second low Bidder, it must be submitted and received by the Public Works Department no later than 5 working days after Bid opening date.)

In conformance with Article IV to Chapter 12 of the Salinas Municipal Code, each Contractor and Subcontractor shall complete and submit this **Statement of Good Faith Effort**.

Project Title: MonteBella Maintenance District

Contractor (or Subcontractor): Silvino Sanchez Landscaping

Address: 328 Roberts Ave.

City: Seaside State: CA Zip: 93955

Contractor (or Subcontractor) estimates that fifty percent (50%) or more of its workforce, for this project, meets the local hire requirements for this contract:

Yes No **If "No", the apparent successful Bidder (low Bidder) and the second low Bidder shall complete and submit the following form to the office at which bids were received so the information is received by the Department no later than 5 working days after bid opening:**

Name and Address of Local Recruitment Source	Date of Recruit. Contact	Person Contacted and Phone #	Recruitment For: Trade & Classification	Number of Referrals Requested	# of Local Hires as Result of Contact	Names and address of Local Hire (2) as a Result of Contact

I certify that the information contained in this form is true and correct, to the best of my knowledge, (Please sign all pages.) (Submitted under penalty of perjury, Salinas City Code, Section 12-31.)

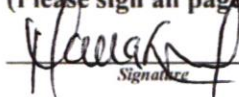
 Maria Eugenia Diaz Bookkeeper 06/07/2021
Signature Name (Please Print) Title or Position (Please Print) Date

Attach Notary Acknowledgment

Page ___ of ___

CALIFORNIA ALL-PURPOSE ACKNOWLEDGMENT

CIVIL CODE § 1189

A notary public or other officer completing this certificate verifies only the identity of the individual who signed the document to which this certificate is attached, and not the truthfulness, accuracy, or validity of that document.

State of California
County of Monterey
On 06/07/2021 before me, Candace T. Hare, Notary Public
personally appeared Maria Eugenia Diaz

who proved to me on the basis of satisfactory evidence to be the person(s) whose name(s) is/are subscribed to the within instrument and acknowledged to me that he/she/they executed the same in his/her/their authorized capacity(ies), and that by his/her/their signature(s) on the instrument the person(s), or the entity upon behalf of which the person(s) acted, executed the instrument.

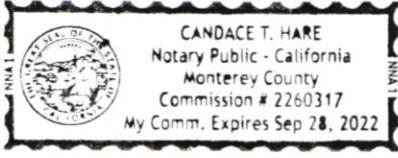

I certify under PENALTY OF PERJURY under the laws of the State of California that the foregoing paragraph is true and correct.

WITNESS my hand and official seal.

Signature of Notary Public (handwritten signature)

Place Notary Seal and/or Stamp Above

OPTIONAL

Completing this information can deter alteration of the document or fraudulent reattachment of this form to an unintended document.

Description of Attached Document
Title or Type of Document: Statement of Good Faith Effort for Local Hire
Document Date: Number of Pages:
Signer(s) Other Than Named Above:
Capacity(ies) Claimed by Signer(s)
Signer's Name:
Corporate Officer - Title(s):
Partner - Limited General
Individual Attorney in Fact
Trustee Guardian of Conservator
Other:
Signer is Representing:

STATEMENT OF GOOD FAITH EFFORT FOR LOCAL HIRE

For

**The City of Salinas
Public Works Department**

(This information may be submitted with your proposal. If it is not, and you are the apparent low Bidder or the second low Bidder, it must be submitted and received by the Public Works Department no later than 5 working days after Bid opening date.)

In conformance with Article IV to Chapter 12 of the Salinas Municipal Code, each Contractor and Subcontractor shall complete and submit this **Statement of Good Faith Effort**.

Project Title: Landscape Services for Monte Bella Maintenance District

Contractor (or Subcontractor): Hemi's Landscaping and Concrete, Inc

Address: 446 Boronda Rd

City: Salinas State: CA Zip: 93907

Contractor (or Subcontractor) estimates that fifty percent (50%) or more of its workforce, for this project, meets the local hire requirements for this contract:

Yes No

If "No", the apparent successful Bidder (low Bidder) and the second low Bidder shall complete and submit the following form to the office at which bids were received so the information is received by the Department no later than 5 working days after bid opening:

Name and Address of Local Recruitment Source	Date of Recruit. Contact	Person Contacted and Phone #	Recruitment For: Trade & Classification	Number of Referrals Requested	# of Local Hires as Result of Contact	Names and address of Local Hire (2) as a Result of Contact

I certify that the information contained in this form is true and correct, to the best of my knowledge, (Please sign all pages.) (Submitted under penalty of perjury, Salinas City Code, Section 12-31.)

Signature

Isidro Hernandez
Name (Please Print)

President
Title or Position (Please Print)

06/04/2021
Date

Attach Notary Acknowledgment

Page ___ of ___

ACKNOWLEDGMENT

A notary public or other officer completing this certificate verifies only the identity of the individual who signed the document to which this certificate is attached, and not the truthfulness, accuracy, or validity of that document.

State of California
County of MONTEREY)

On JUNE 4, 2021 before me, RUBI LEON RAMIREZ - NOTARY PUBLIC
(insert name and title of the officer)

personally appeared ISIDRO HERNANDEZ MURILLO,
who proved to me on the basis of satisfactory evidence to be the person(s) whose name(s) is/are
subscribed to the within instrument and acknowledged to me that he/she/they executed the same in
his/her/their authorized capacity(ies), and that by his/her/their signature(s) on the instrument the
person(s), or the entity upon behalf of which the person(s) acted, executed the instrument.

I certify under PENALTY OF PERJURY under the laws of the State of California that the foregoing
paragraph is true and correct.

WITNESS my hand and official seal.

Signature  (Seal)

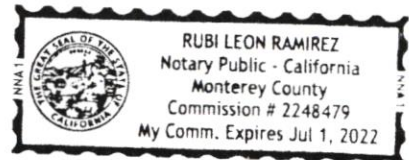

**BIDDER'S LIST
FOR
THE CITY OF SALINAS
PUBLIC WORKS DEPARTMENT**

(This information may be submitted with your proposal. If it is not, and you are the apparent low Bidder or the second low Bidder, it must be submitted and received by the Public Works Department no later than 5 working days after Bid opening date.)

All Bidders are required to provide the following information for all DBE and non-DBE contractors who provided a proposal, Bid, quote, or were contacted by the proposed prime. This information is also required from the proposed prime Contractor and must be submitted with their Bid/proposal. In order for the City of Salinas to conform with Federally-Mandated DBE Program Bidders List, it will use this information to maintain and update a "Bidders List" to assist in the overall annual goal DBE goal setting process.

Firm Name: Smith & Enright Landscaping, Inc Phone: 831-758-6766

Address: 540 Work St Suite C Fax: 831-758-5589

Salinas, CA 93901 License No.: 757700

DIR Registration No.: 1000011127 Exp. Date: 06/30/23

Contact Person & Title: Selena Herrin, General Manager No. of Years in Business: 37

Is the firm currently certified as a DBE under the new regulations (49 CFR Part 26)? Yes No

Type of work/services/materials provided by firm: Landscape Installation & Maintenance

What were your firm's Gross Annual receipts for last year?

- Less than \$1 Million
- Less than \$5 Million
- Less than \$10 Million
- Less than \$15 Million
- More than \$15 Million

I declare under penalty of perjury under the laws of the State of California that the foregoing is true and correct.

SIGNED:  06/07/21
(Date)

This form may be copied as needed to report all Bidders (DBEs and non-DBEs) information.

Revision Date 11 17 17

**SEE ATTACHED
NOTARY CERTIFICATE**

CALIFORNIA ALL-PURPOSE CERTIFICATE OF ACKNOWLEDGMENT

A notary public or other officer completing this certificate verifies only the identity of the individual who signed the document to which this certificate is attached, and not the truthfulness, accuracy, or validity of that document

State of California
County of Monterey

On June 7, 2021 before me, Vanessa Paradise, Notary Public
personally appeared Selena Hessin

who proved to me on the basis of satisfactory evidence to be the person(s) whose name(s) is/are subscribed to the within instrument and acknowledged to me that he/she/they executed the same in his/her/their authorized capacity(ies), and that by his/her/their signature(s) on the instrument the person(s), or the entity upon behalf of which the person(s) acted, executed the instrument.



NOTARY SEAL

I certify under PENALTY OF PERJURY under the laws of the State of California that the foregoing paragraph is true and correct.

WITNESS my hand and official seal.

Signature

Van Paradise

Signature of Notary Public

ADDITIONAL OPTIONAL INFORMATION

Title or Description of attached document: Bidders List for the
City of Salinas Public Works Department

Document Date: June 7, 2021 Number of Pages: - ONE -

Capacity(ies) Claimed by Signer

Signer's Name: _____

- Individual
- Corporate Officer
- Partner
- Attorney-in-Fact
- Trustee
- Other: _____

Signer is representing _____

Capacity(ies) Claimed by Signer

Signer's Name: _____

- Individual
- Corporate Officer
- Partner
- Attorney-in-Fact
- Trustee
- Other: _____

Signer is representing _____

**BIDDER'S LIST
FOR
THE CITY OF SALINAS
PUBLIC WORKS DEPARTMENT**

(This information may be submitted with your proposal. If it is not, and you are the apparent low Bidder or the second low Bidder, it must be submitted and received by the Public Works Department no later than 5 working days after Bid opening date.)

All Bidders are required to provide the following information for all DBE and non-DBE contractors who provided a proposal, Bid, quote, or were contacted by the proposed prime. This information is also required from the proposed prime Contractor and must be submitted with their Bid/proposal. In order for the City of Salinas to conform with Federally-Mandated DBE Program Bidders List, it will use this information to maintain and update a "Bidders List" to assist in the overall annual goal DBE goal setting process.

Firm Name: Silvino Sanchez Landscaping Phone: 831-521-3782

Address: 328 Roberts Ave. Fax: _____

Seaside CA 93955 License No.: 1009392

DIR Registration No.: 1000726545 Exp. Date: 06/30/2021

Contact Person & Title: Maria Eugenia Diaz, Bookkeeper No. of Years in Business: 6

Is the firm currently certified as a DBE under the new regulations (49 CFR Part 26)? Yes No

Type of work/services/materials provided by firm: Tree work & landscaping

What were your firm's Gross Annual receipts for last year?

- Less than \$1 Million
- _____ Less than \$5 Million
- _____ Less than \$10 Million
- _____ Less than \$15 Million
- _____ More than \$15 Million

I declare under penalty of perjury under the laws of the State of California that the foregoing is true and correct.

SIGNED: [Signature] 06/07/2021
(Date)

This form may be copied as needed to report all Bidders (DBEs and non-DBEs) information.

Revision Date 11/17/17

CALIFORNIA ALL-PURPOSE ACKNOWLEDGMENT

CIVIL CODE § 1189

A notary public or other officer completing this certificate verifies only the identity of the individual who signed the document to which this certificate is attached, and not the truthfulness, accuracy, or validity of that document.

State of California
County of Monterey
On 06/07/2021 before me, Candace T. Hare, Notary Public
Date Here Insert Name and Title of the Officer
personally appeared Maria Gujenni Diaz
Name(s) of Signer(s)

who proved to me on the basis of satisfactory evidence to be the person(s) whose name(s) is/are subscribed to the within instrument and acknowledged to me that he/she/they executed the same in his/her/their authorized capacity(ies), and that by his/her/their signature(s) on the instrument the person(s), or the entity upon behalf of which the person(s) acted, executed the instrument.

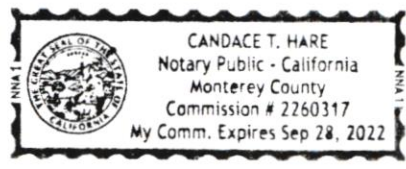

I certify under PENALTY OF PERJURY under the laws of the State of California that the foregoing paragraph is true and correct.

WITNESS my hand and official seal.

Signature [Handwritten Signature]
Signature of Notary Public

Place Notary Seal and/or Stamp Above

OPTIONAL

Completing this information can deter alteration of the document or fraudulent reattachment of this form to an unintended document.

Description of Attached Document
Title or Type of Document: Bidders List for the City of Salinas
Document Date: Pub works Dept. Number of Pages:
Signer(s) Other Than Named Above:

Capacity(ies) Claimed by Signer(s)
Signer's Name:
[] Corporate Officer - Title(s):
[] Partner - [] Limited [] General
[] Individual [] Attorney in Fact
[] Trustee [] Guardian of Conservator
[] Other:
Signer is Representing:

**BIDDER'S LIST
FOR
THE CITY OF SALINAS
PUBLIC WORKS DEPARTMENT**

Landscape Services for North/East Maintenance District

(This information may be submitted with your proposal. If it is not, and you are the apparent low Bidder or the second low Bidder, it must be submitted and received by the Public Works Department no later than 5 working days after Bid opening date.)

All Bidders are required to provide the following information for all DBE and non-DBE contractors who provided a proposal, Bid, quote, or were contacted by the proposed prime. This information is also required from the proposed prime Contractor and must be submitted with their Bid/proposal. In order for the City of Salinas to conform with Federally-Mandated DBE Program Bidders List, it will use this information to maintain and update a "Bidders List" to assist in the overall annual goal DBE goal setting process.

Firm Name: Hemi's Landscaping and Concrete, Inc Phone: 831-594-6182

Address: 446 Boronda Rd Fax: _____

Salinas, CA 93901 License No.: 903795

DIR Registration No.: 1000020090 Exp. Date: 06/30/23

Contact Person & Title: Isidro Hernandez - President No. of Years in Business: _____

Is the firm currently certified as a DBE under the new regulations (49 CFR Part 26)? Yes No

Type of work/services/materials provided by firm: Landscaping and Concrete

What were your firm's Gross Annual receipts for last year?

- Less than \$1 Million
- Less than \$5 Million
- Less than \$10 Million
- Less than \$15 Million
- More than \$15 Million

I declare under penalty of perjury under the laws of the State of California that the foregoing is true and correct.

SIGNED:  06/04/21
(Date)

This form may be copied as needed to report all Bidders (DBEs and non-DBEs) information.

Revision Date 11 17 17

ACKNOWLEDGMENT

A notary public or other officer completing this certificate verifies only the identity of the individual who signed the document to which this certificate is attached, and not the truthfulness, accuracy, or validity of that document.

State of California
County of MONTEREY)

On JUNE 4, 2021 before me, RUBI LEON RAMIREZ - NOTARY PUBLIC
(insert name and title of the officer)

personally appeared ISIDRO HERNANDEZ MURILLO,
who proved to me on the basis of satisfactory evidence to be the person(s) whose name(s) is/are
subscribed to the within instrument and acknowledged to me that he/she/they executed the same in
his/her/their authorized capacity(ies), and that by his/her/their signature(s) on the instrument the
person(s), or the entity upon behalf of which the person(s) acted, executed the instrument.

I certify under PENALTY OF PERJURY under the laws of the State of California that the foregoing
paragraph is true and correct.

WITNESS my hand and official seal.

Signature  (Seal)

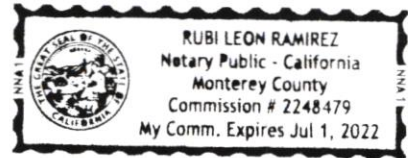

**PART B –
SUCCESSFUL BIDDER’S CONTRACT DOCUMENTS TO BE
SUBMITTED AFTER PROJECT IS AWARDED**

GENERAL INSTRUCTIONS TO LOW BIDDER

BIDDER'S SIGNATURES

- (A) The Bidder shall sign two documents included in the Bid Documents:
1. Agreement
 2. Bidder's Security
- (B) The name of the Bidder shall be typewritten or printed below the signature line. The type of legal entity shall be included in the name of the Bidder (examples: individual, sole proprietorship, general partnership, limited partnership, or corporation).
- (C) The name and title of all individuals signing for the entity shall be typewritten or printed below the signature line. **All signatures shall be notarized with a notary acknowledgment.**
- (D) The Bidder shall provide evidence that the individual signing the document is authorized to bind the legal entity of the Bidder. The notarization does not constitute such proof unless the Bidder is signing as an individual.
- (E) If the Bidder is a corporation, proof of authorization shall be established (pursuant to Corporations Code Section 313) if one of the corporate officers listed in column A below and one of the corporate officers listed in column B below both sign the documents.

A		B
Chairman of the Board		Secretary
or		or
President	<u>AND</u>	Assistant Secretary
or		or
Vice President		Chief Financial Officer
		or
		Assistant Treasurer

For any other combination of signatures of corporate officers, a copy of the Board minutes, resolution, or articles of incorporation may be submitted to prove that the individuals have the authority to bind the corporation.

- (F) If the Bidder is any legal entity other than an individual or corporation, documentation must be submitted which establishes that the individuals have the legal authority to bind the legal entity of the Bidder.

- (G) If the legal entity is a Limited Partnership, a Certificate of Limited Partnership (State form LP-1) is sufficient to establish the authority of a single General Partner to bind the Limited Partnership.
- (H) If the Bidder is a General Partnership, a Certificate of General Partnership or General Partnership Agreement is sufficient to establish the names of all general partners of a General Partnership.
- (I) All general partners must sign the documents, unless proof is submitted which authorizes an individual partner to bind the other general partners.
- (J) If the individual signing the document is signing as a sole proprietorship, either a Fictitious Business Name Statement or a City of Salinas business License is sufficient to establish the authority of an individual to bind a sole proprietorship.
- (K) If the individual or individuals signing the documents are signing on behalf of an entity other than the Bidder, and that other entity is authorized to bind the legal entity of the Bidder, then documentation must be submitted which establishes that the individuals have the authority to bind the other entity, and that the other entity has the authority to bind the legal entity of the Bidder.

BIDDER'S/CONTRACTOR'S SECURITY

All Bidders' security (including Bid Bond, Labor and Materials Bond, and any other required bond) shall be in one of the following forms:

- a. Cash
- b. Cashier's check made payable to the City
- c. A certified check made payable to the City

A bond executed by an admitted surety insurer, made payable to the City in the form of the bonds in the Contract documents. The Power of attorney for the attorney-in-fact of the surety must be current, contain an authorization to bind for at least minimum dollar amount of the bond, and be attached to the bond. **The signature of the attorney-in-fact must be notarized.**

**PAYMENT BOND
(LABOR AND MATERIAL BOND)**

(To be completed and submitted after project award)

KNOW ALL MEN BY THESE PRESENT, that WHEREAS, the City Council of the City of Salinas, Monterey County, State of California, by Resolution No. 22149 (N.C.S.)

passed June 8, 2021, has been awarded to

Smith & Enright Landscaping, Inc. hereinafter designated as "Principal," a Contract for

LANDSCAPE SERVICES FOR MONTE BELLA MAINTENANCE DISTRICT

WHEREAS, said Principal is required to furnish a bond in connection and with said Contract, provided that if said Principal or any of his/her or its Subcontractors shall fail to pay for any materials, provisions, provender or other supplies or teams used in, upon, for or about the performance for the work Contracted to be done for any work or labor done thereon of any kind, the Surety of this bond will pay the same to the extend hereinafter set forth;

WHEREAS, said Principal is required under the terms of said Contract to furnish a Bond for the faithful performance of said Contract;

Now, therefore, We, the Principal and Platte River Insurance Company as

Surety, are held and firmly bounded to the City of Salinas, Monterey County, California, in the penal sum of One Hundred Forty Three Thousand Eight Hundred Twenty and 00/100

(\$ 143,820.00) Dollars, lawful money of the United States, being not less than 100% of the estimated Contract cost of the work, for the payment of which sum well and truly to be made, we bind ourselves, our heirs, executors, administrators, and successors, jointly and severally, firmly by these presents.

THE CONDITION OF THIS OBLIGATION IS SUCH, that if said Principal, or any of his/her heirs, executors, administrators, successors, or assigns shall fail to pay for any materials, provisions, provender, or other supplies or teams used in, upon, for, or about the performance of the work Contracted to be done, or for any work or labor thereon of any respect to such work or labor, as required by the provisions of Division 2, Part 1, Chapter 5 of the Public Contracts Code of the State of California, and provided that the persons, companies, or other supplies, teams, appliances, or power used in, upon, for, or about the performance of the work contracted to be executed or performed, or any person, company, or corporation renting or hiring teams, implements, or machinery of power for or contributing to said work to be done, or any person who performs work or labor upon same, or any person who supplies both work and materials therefore, shall have complied with the Provisions of said Government Code, then said Surety will pay the same in or to an amount not exceeding the amount hereinabove set forth, and also will pay in case suit is

brought upon this bond, such reasonable attorney's fee as shall be fixed by the court, awarded and taxed as in the above-mentioned Code provided.

This bond shall inure to the benefit of any and all persons, companies, and corporations entitled to file claims under said Government Code so as to give a right to action to them or their assigns in any suit brought upon this bond.

And the said Surety, for value received, hereby stipulates and agrees that no change, extension of time, alteration, or addition to the terms of the Contract, to the work to be performed thereunder, or the Specifications accompanying the same shall in anyway affect its obligations of this bond, and it does hereby waive notice of any such change, extension of time, alteration, or addition to the terms of the Contract, to the work, or to the Specifications.

IN WITNESS WHEREOF, the above bond parties have executed this instrument under their seals this 12 day of July, 2021, the name and corporate seal of each corporate party being hereto affixed and these presents duly signed by its undersigned representative; pursuant to authority of its governing body.

Principal Name: Smith & Enright Landscaping, Inc.

Address: 540 Work St., Ste C

Salinas, CA 93901

SEE ATTACHED
NOTARY CERTIFICATE

(Attach Notary Acknowledgment)

By:  , CFO
(Signature in blue ink)

By: _____
(Signature in blue ink)

Surety Name: Platte River Insurance Company

Address: P.O. Box 5900

Madison, WI 53705-0900

(Attach Notary Acknowledgment)

By:  Chris Eley, Attorney-In-Fact
(Signature in blue ink)

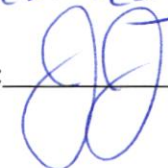
By:  Jason Jenkins, Attorney-In-Fact
(Signature in blue ink)

ACKNOWLEDGMENT

STATE OF ARKANSAS)
)ss.
COUNTY OF Saline)

BE IT REMEMBERED, on this day, personally appeared before me,
Chris Eley, known to me to be the person whose name is subscribed to
the foregoing as attorney-in-fact, and acknowledged that he executed the same for the
purposes therein contained.

WITNESS my hand and official seal this 12 day of July, 2021.

Kimberly Lynette Sohl
Notary Public

My Commission Expires: December 9, 2025

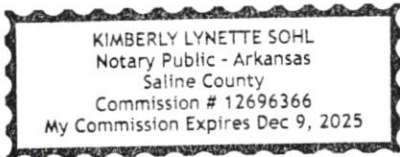

(SEAL)

ACKNOWLEDGMENT

STATE OF ARKANSAS)
)ss.
COUNTY OF Saline)

BE IT REMEMBERED, on this day, personally appeared before me,
Jaden Jenkins, known to me to be the person whose name is subscribed to
the foregoing as attorney-in-fact, and acknowledged that he executed the same for the
purposes therein contained.

WITNESS my hand and official seal this 12 day of July, 2021.

Kimberly Lynette Sohl
Notary Public

My Commission Expires: December 9, 2025

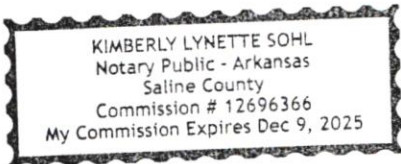

(SEAL)

CALIFORNIA ALL-PURPOSE CERTIFICATE OF ACKNOWLEDGMENT

A notary public or other officer completing this certificate verifies only the identity of the individual who signed the document to which this certificate is attached, and not the truthfulness, accuracy, or validity of that document

State of California
County of Monterey

On July 15, 2021 before me, Vanessa Paradise, Notary Public
personally appeared Richard A. Enright

who proved to me on the basis of satisfactory evidence to be the person(s) whose name(s) is/are subscribed to the within instrument and acknowledged to me that he/she/they executed the same in his/her/their authorized capacity(ies), and that by his/her/their signature(s) on the instrument the person(s), or the entity upon behalf of which the person(s) acted, executed the instrument.



NOTARY SEAL

I certify under PENALTY OF PERJURY under the laws of the State of California that the foregoing paragraph is true and correct.

WITNESS my hand and official seal.

Signature

Van Paradise

Signature of Notary Public

ADDITIONAL OPTIONAL INFORMATION

Title or Description of attached document: Invitation to Bid -

Document Date: No Date Number of Pages: -103-

Capacity(ies) Claimed by Signer

Signer's Name: _____

- Individual
- Corporate Officer
- Partner
- Attorney-in-Fact
- Trustee
- Other: _____

Signer is representing _____

Capacity(ies) Claimed by Signer

Signer's Name: _____

- Individual
- Corporate Officer
- Partner
- Attorney-in-Fact
- Trustee
- Other: _____

Signer is representing _____

PLATTE RIVER INSURANCE COMPANY
POWER OF ATTORNEY

PR2730382

Bond Number

KNOW ALL MEN BY THESE PRESENTS, That the PLATTE RIVER INSURANCE COMPANY, a corporation of the State of Nebraska, having its principal offices in the City of Middleton, Wisconsin, does make, constitute and appoint

CHRIS ELEY; AMELIA MCSHANE; JASON JENKINS

its true and lawful Attorney(s)-in-fact, to make, execute, seal and deliver for and on its behalf, as surety, and as its act and deed, any and all bonds, undertakings and contracts of suretyship, provided that no bond or undertaking or contract of suretyship executed under this authority shall exceed in amount the sum of

ALL WRITTEN INSTRUMENTS IN AN AMOUNT NOT TO EXCEED: \$20,000,000.00

This Power of Attorney is granted and is signed and sealed by facsimile under and by the authority of the following Resolution adopted by the Board of Directors of PLATTE RIVER INSURANCE COMPANY at a meeting duly called and held on the 8th day of January, 2002.

RESOLVED, that the President, Executive Vice President, Vice President, Secretary or Treasurer, acting individually or otherwise, be and they hereby are granted the power and authorization to appoint by a Power of Attorney for the purposes only of executing and attesting bonds and undertakings, and other writings obligatory in the nature thereof, one or more resident vice-presidents, assistant secretaries and attorney(s)-in-fact, each appointee to have the powers and duties usual to such offices to the business of this company; the signature of such officers and seal of the Company may be affixed to any such power of attorney or to any certificate relating thereto by facsimile, and any such power of attorney or certificate bearing such facsimile signatures or facsimile seal shall be valid and binding upon the Company, and any such power so executed and certified by facsimile signatures and facsimile seal shall be valid and binding upon the Company in the future with respect to any bond or undertaking or other writing obligatory in the nature thereof to which it is attached. Any such appointment may be revoked, for cause, or without cause, by any of said officers, at any time.

In connection with obligations in favor of the Florida Department of Transportation only, it is agreed that the power and authority hereby given to the Attorney-in-Fact includes any and all consents for the release of retained percentages and/or final estimates on engineering and construction contracts required by the State of Florida Department of Transportation. It is fully understood that consenting to the State of Florida Department of Transportation making payment of the final estimate to the Contractor and/or its assignee, shall not relieve this surety company of any of its obligations under its bond.

In connection with obligations in favor of the Kentucky Department of Highways only, it is agreed that the power and authority hereby given to the Attorney-in-Fact cannot be modified or revoked unless prior written personal notice of such intent has been given to the Commissioner - Department of Highways of the Commonwealth of Kentucky at least thirty (30) days prior to the modification or revocation.

IN WITNESS WHEREOF, the PLATTE RIVER INSURANCE COMPANY has caused these presents to be signed by its officer undersigned and its corporate seal to be hereto affixed duly attested, this 1st day of January, 2020.

Attest:

[Signature of Ryan J. Byrnes]

Ryan J. Byrnes
Senior Vice President,
Chief Financial Officer and Treasurer

[Signature of Suzanne M. Broadbent]

Suzanne M. Broadbent
Assistant Secretary



PLATTE RIVER INSURANCE COMPANY

[Signature of John L. Sennott, Jr.]

John L. Sennott, Jr.
Chief Executive Officer and President

STATE OF WISCONSIN } S.S.:
COUNTY OF DANE

On the 1st day of January, 2020 before me personally came John L. Sennott, Jr., to me known, who being by me duly sworn, did depose and say: that he resides in the County of Hartford, State of Connecticut; that he is Chief Executive Officer and President of PLATTE RIVER INSURANCE COMPANY, the corporation described in and which executed the above instrument; that he knows the seal of the said corporation; that the seal affixed to said instrument is such corporate seal; that it was so affixed by order of the Board of Directors of said corporation and that he signed his name thereto by like order.



[Signature of David J. Regele]

David J. Regele
Notary Public, Dane Co., WI
My Commission Is Permanent

STATE OF WISCONSIN } S.S.:
COUNTY OF DANE

I, the undersigned, duly elected to the office stated below, now the incumbent in PLATTE RIVER INSURANCE COMPANY, a Nebraska Corporation, authorized to make this certificate, DO HEREBY CERTIFY that the foregoing attached Power of Attorney remains in full force and has not been revoked; and furthermore, that the Resolution of the Board of Directors, set forth in the Power of Attorney is now in force.

Signed and sealed at the City of Middleton, State of Wisconsin this 12 day of July, 2021



[Signature of Andrew B. Diaz-Matos]

Andrew B. Diaz-Matos
Senior Vice President, General Counsel and Secretary

BOND RIDER

ATTACHED TO AND FORMING A PART OF:

Bond Number: PR2730382

Bond Amount: \$143,820.00

Principal: Smith & Enright Landscaping, Inc.

Obligee: City of Salinas

Surety: Platte River Insurance Company

Effective 7/12/2021, it is agreed that:

It is expressly understood that the contract award date is amended to be 6/22/2021.

Nothing herein contained shall be held to vary, waive, alter, or extend any of the terms, conditions, agreements or warranties of the above mentioned bond, other than stated as above. Provided, however, that the liability of the company under the attached bond as changed by this order shall not be cumulative and shall not exceed the amount stated above.

Signed this 23 day of July, 2021

Principal: Smith & Enright Landscaping, Inc.

By:  _____

SEE ATTACHED
NOTARY CERTIFICATE

Surety: Platte River Insurance Company

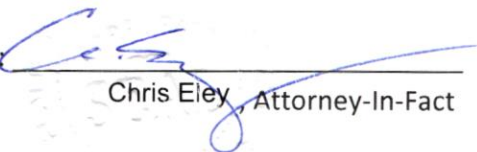
By:  _____
Chris Eley, Attorney-In-Fact

CALIFORNIA ALL-PURPOSE CERTIFICATE OF ACKNOWLEDGMENT

A notary public or other officer completing this certificate verifies only the identity of the individual who signed the document to which this certificate is attached, and not the truthfulness, accuracy, or validity of that document

State of California
County of Monterey

On July 28, 2021 before me, April Wilson, Notary Public
personally appeared Richard A. Enright

who proved to me on the basis of satisfactory evidence to be the person(s) whose name(s) is/are subscribed to the within instrument and acknowledged to me that he/she/they executed the same in his/her/their authorized capacity(ies), and that by his/her/their signature(s) on the instrument the person(s), or the entity upon behalf of which the person(s) acted, executed the instrument.

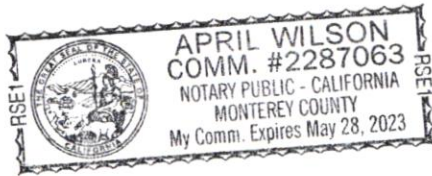

NOTARY SEAL

I certify under PENALTY OF PERJURY under the laws of the State of California that the foregoing paragraph is true and correct.

WITNESS my hand and official seal.

Signature April Wilson
Signature of Notary Public

ADDITIONAL OPTIONAL INFORMATION

Title or Description of attached document: Invitation to Bid "Bond Rider"

Document Date: 7/23/21 Number of Pages: - 103 -

Capacity(ies) Claimed by Signer

Signer's Name: _____

- Individual
 Corporate Officer _____
 Partner
 Attorney-in-Fact
 Trustee
 Other: _____

Signer is representing _____

Capacity(ies) Claimed by Signer

Signer's Name: _____

- Individual
 Corporate Officer _____
 Partner
 Attorney-in-Fact
 Trustee
 Other: _____

Signer is representing _____

PLATTE RIVER INSURANCE COMPANY
POWER OF ATTORNEY

PR2730382

Bond Number

KNOW ALL MEN BY THESE PRESENTS, That the PLATTE RIVER INSURANCE COMPANY, a corporation of the State of Nebraska, having its principal offices in the City of Middleton, Wisconsin, does make, constitute and appoint

CHRIS ELEY; AMELIA MCSHANE; JASON JENKINS

its true and lawful Attorney(s)-in-fact, to make, execute, seal and deliver for and on its behalf, as surety, and as its act and deed, any and all bonds, undertakings and contracts of suretyship, provided that no bond or undertaking or contract of suretyship executed under this authority shall exceed in amount the sum of

ALL WRITTEN INSTRUMENTS IN AN AMOUNT NOT TO EXCEED: \$20,000,000.00

This Power of Attorney is granted and is signed and sealed by facsimile under and by the authority of the following Resolution adopted by the Board of Directors of PLATTE RIVER INSURANCE COMPANY at a meeting duly called and held on the 8th day of January, 2002.

RESOLVED, that the President, Executive Vice President, Vice President, Secretary or Treasurer, acting individually or otherwise, be and they hereby are granted the power and authorization to appoint by a Power of Attorney for the purposes only of executing and attesting bonds and undertakings, and other writings obligatory in the nature thereof, one or more resident vice-presidents, assistant secretaries and attorney(s)-in-fact, each appointee to have the powers and duties usual to such offices to the business of this company; the signature of such officers and seal of the Company may be affixed to any such power of attorney or to any certificate relating thereto by facsimile, and any such power of attorney or certificate bearing such facsimile signatures or facsimile seal shall be valid and binding upon the Company, and any such power so executed and certified by facsimile signatures and facsimile seal shall be valid and binding upon the Company in the future with respect to any bond or undertaking or other writing obligatory in the nature thereof to which it is attached. Any such appointment may be revoked, for cause, or without cause, by any of said officers, at any time.

In connection with obligations in favor of the Florida Department of Transportation only, it is agreed that the power and authority hereby given to the Attorney-in-Fact includes any and all consents for the release of retained percentages and/or final estimates on engineering and construction contracts required by the State of Florida Department of Transportation. It is fully understood that consenting to the State of Florida Department of Transportation making payment of the final estimate to the Contractor and/or its assignee, shall not relieve this surety company of any of its obligations under its bond.

In connection with obligations in favor of the Kentucky Department of Highways only, it is agreed that the power and authority hereby given to the Attorney-in-Fact cannot be modified or revoked unless prior written personal notice of such intent has been given to the Commissioner - Department of Highways of the Commonwealth of Kentucky at least thirty (30) days prior to the modification or revocation.

IN WITNESS WHEREOF, the PLATTE RIVER INSURANCE COMPANY has caused these presents to be signed by its officer undersigned and its corporate seal to be hereto affixed duly attested, this 1st day of January, 2020.

Attest:

Handwritten signatures of Ryan J. Byrnes and Suzanne M. Broadbent with their titles: Senior Vice President, Chief Financial Officer and Treasurer; Assistant Secretary.



PLATTE RIVER INSURANCE COMPANY

Handwritten signature of John L. Sennott, Jr. with title: Chief Executive Officer and President.

STATE OF WISCONSIN } S.S.:
COUNTY OF DANE

On the 1st day of January, 2020 before me personally came John L. Sennott, Jr., to me known, who being by me duly sworn, did depose and say: that he resides in the County of Hartford, State of Connecticut; that he is Chief Executive Officer and President of PLATTE RIVER INSURANCE COMPANY, the corporation described in and which executed the above instrument; that he knows the seal of the said corporation; that the seal affixed to said instrument is such corporate seal; that it was so affixed by order of the Board of Directors of said corporation and that he signed his name thereto by like order.



Handwritten signature of David J. Regele with title: Notary Public, Dane Co., WI My Commission Is Permanent.

STATE OF WISCONSIN } S.S.:
COUNTY OF DANE

I, the undersigned, duly elected to the office stated below, now the incumbent in PLATTE RIVER INSURANCE COMPANY, a Nebraska Corporation, authorized to make this certificate, DO HEREBY CERTIFY that the foregoing attached Power of Attorney remains in full force and has not been revoked; and furthermore, that the Resolution of the Board of Directors, set forth in the Power of Attorney is now in force.

Signed and sealed at the City of Middleton, State of Wisconsin this 23 day of July, 2021



Handwritten signature of Andrew B. Diaz-Matos with title: Senior Vice President, General Counsel and Secretary.

ACKNOWLEDGMENT

STATE OF ARKANSAS)
)ss.
COUNTY OF Saline)

BE IT REMEMBERED, on this day, personally appeared before me,
Chris Eley, known to me to be the person whose name is subscribed to
the foregoing as attorney-in-fact, and acknowledged that he executed the same for the
purposes therein contained.

WITNESS my hand and official seal this 23 day of July, 2021.

Kimberly Lynette Sohl
Notary Public

My Commission Expires: December 9, 2025

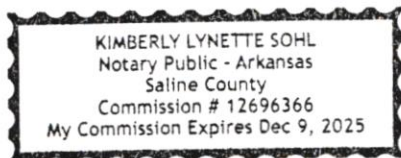

(S E A L)

AGREEMENT

(To be completed and submitted for project award)

THIS AGREEMENT, made and entered into this 22nd day of June, 2021, by and between the CITY OF SALINAS, a municipal corporation of the State of California, hereinafter called "City", and Smith & Enright Landscaping, Inc. hereinafter called "Contractor",

WITNESSETH

FIRST: Contractor hereby covenants and agrees to furnish and provide all labor, materials, tools, appliances, equipment, plant, transportation, and all other things required or necessary to be furnished, provided or done, and build, erect, construct, and complete the work at the time and in the manner provided, and in strict accordance with the Plans and Specifications therefore, for

LANDSCAPE SERVICES FOR MONTE BELLA MAINTENANCE DISTRICT

SECOND: It is expressly understood and agreed that this Contract consists of the following documents, all of which are incorporated into this Agreement and made a part hereof as fully and completely as if set forth herein verbatim, to wit:

- a. **Notice Inviting Sealed Proposals**
- b. **Signed and executed Bid and Proposal of Contractor, and if any signed Addendum, as accepted by City**
- c. **Bidder's Statement of Financial Responsibility, Technical Ability and Experience**
- d. **Bidder's Statement of Subcontractors – Part I**
- e. **Bidder's Statement of Subcontractors – Part II**
- f. **Insurance Certification**
- g. **Completely executed and signed all required City of Salinas forms**
- h. **Instructions to Successful Bidder and General conditions**
- i. **Payment Bond (Labor and Materials Bond)**
- j. **Certificate of Insurance**
- k. **The aforesaid Plans and Specifications**
- l. **Design Standards and Standard Specifications and Standard Plans, 2008 Edition, or as amended, or otherwise indicated in the specifications and**
- m. **this Agreement.**

THIRD: That said Contractor agrees to receive and accept the following prices as full compensation for furnishing all materials and for doing all the work embraced and contemplated in this Agreement, and as set forth in the Proposal adopted by the City of Salinas, a true copy thereof hereto attached; also, for all loss or damage arising out of the nature of said work, from the action of the elements, or from any unforeseen difficulties or obstructions which may arise or be encountered in the prosecution of the work until the acceptance thereof by the City of Salinas, and for all risk connected with the work, and for well and faithfully completing the work, and the whole thereof, in the manner and according to the said Plans and Specifications and the Provisions of this agreement and the requirements of the City Engineer under them, to wit: The prices as set forth in the Proposal of said Contractor for the work to be constructed and completed under this Agreement, which prices shall be considered as though repeated herein.

The Contractor and City hereby agree that the Contractor shall perform the work, and be paid the amount of bid items No. 1 specified in the Proposal of the Contractor, for the as total price of One Hundred Forty Three, Eight Hundred Twenty (\$ 143,820) Dollars.

The undersigned Contractor further agrees to so plan the work and to prosecute it with such diligence that said work, and all of it, shall be completed on or before the expiration of the time specified in the Proposal after execution of the Contract on behalf of the City of Salinas and the receipt from the City of Salinas of a Notice to Proceed with the work.

FOURTH: The City of Salinas hereby promises and agrees with said Contractor to employ, and does hereby employ, said Contractor to provide the materials and to do the work according to the terms and conditions herein contained and referred to, for the price aforesaid, and hereby Contracts to pay the same at the time, in the manner, and upon the conditions set forth in the Specifications and the said parties, for themselves, their heirs, executors, administrators, successors, and assigns, do hereby agree to the full performance of the covenants herein contained

FIFTH: No interest in this Agreement shall be transferred by the Contractor to any other party, and any such transfer shall cause the annulment of this Contract, so far as the City of Salinas is concerned. All rights of action, however, for any breach of this Contract are reserved to City.

SIXTH: The Contractor shall keep harmless and indemnify the City of Salinas, its officers, agents, and employees from all loss, damage, cost, or expense that arises or is set up for infringement of patent rights of anyone for use by the City of Salinas, its officers, agents, or employees, or articles supplied by the Contractor under this Contract of which he/she is not entitled to use or sell. Contractor agrees to, at his/her own cost and expense, defend in court the City, its officers, agents, and employees in any action which may be commenced or maintained against them or any of the, on account of any claimed infringement of patent rights, arising out of this Agreement.

Contractor shall indemnify and save the City of Salinas, its officers, agents, and employees harmless against all claims for damages to person or property arising out of Contractor's execution of the work, or otherwise by the conduct of the Contractor or its employees, agents, Subcontractors, or others (including the active and passive negligence of the City, its officers, agents, and employees) in connection with the execution of the work covered by this Contract and any and all costs, expenses, attorney's fees, and liability incurred by the City, its officers, agents, or employees in defending against such claims, whether the same proceed to judgment or not, except only those claims arising from the sole negligence or willful conduct of the City, its officers, agents, or employees. Further, Contractor at its own expense shall, upon written request by the City, defend any such suit or action brought against the City, its officers, agents, or employees.

Contractor shall reimburse the City of Salinas for all costs and expenses (including but not limited to fees for architects, engineers, attorneys, and other professional and court costs) incurred by the City in enforcing the Provisions of this Section.

SEVENTH: The Contractor agrees to immediately repair and replace all defective material and workmanship discovered within 1 year after acceptance of final payment by Contractor and to indemnify said City of Salinas against all loss and damage occasioned by any such defect, discovered within said 1 year, even though the damage or loss may not be ascertained until after the expiration thereof. Provided, however, that if such failure of the Contractor to perform should not, by reasonable diligence, be discoverable or discovered

within said 1 year, then the obligation of the Contractor to repair and replace said defective material or workmanship shall continue until one year after the actual discovery thereof.

EIGHTH: Contractor shall procure and maintain for the duration of this Agreement insurance meeting the requirements specified in Attachment A hereto.

NINTH: Contractor agrees to comply with all applicable federal, state and municipal laws and regulations, including but not limited to California Labor Code Division 2, Part 7, Chapter 1.

Apprenticeship utilization: The Contractor agrees to comply with the Department of Apprenticeship Standards of the California Labor Code Section 1777.5 and the following:

Prior to commencing work on the awarded contract, the Contractor shall submit contract award information (form DAS 140) to all applicable apprenticeship program(s) that can supply apprentices to the site of the public work. **A copy of this information shall also be provided to the City of Salinas.**

The ratio of work performed by apprentices to journeyman employed in a particular craft or trade on the public work shall be no less than one hour of apprentice work for every five hours of journeyman work.

At the end of each month of work on the contract, the Contractor and Subcontractors shall submit a record of utilization of apprentices for the previous months work.

Within 60 days after concluding work on the contract, each Contractor and Subcontractor shall submit to the City of Salinas and to the apprenticeship program a verified statement of the journeyman and apprentice hours performed on the contract.

TENTH: Contractor agrees to comply with all requirements of the City of Salinas Local Hiring Preference Ordinance 2330, Salinas City Code Chapter 12, Article IV, which hereby establishes local hiring requirement procedures on Public Works Contracts, with respect to person(s) hired directly by the Contractor and all persons hired by the Contractor's Subcontractor(s).

IN WITNESS WHEREOF, City has caused this instrument to be executed and its corporate name and seal to be hereunto attached by its Mayor, pursuant to resolution theretofore duly adopted by the Council of the City of Salinas, and Contractor has caused this instrument to be executed the day and year first hereinabove written.

ATTEST:

CITY OF SALINAS, A Municipal Corporation
BY Kimbley Craig
Mayor

City Clerk [Signature]

[Signature]
Richard Enright, Vice-President, CFO
540 Work St. Ste C Salinas CA 93901

SEE ATTACHED
NOTARY CERTIFICATE

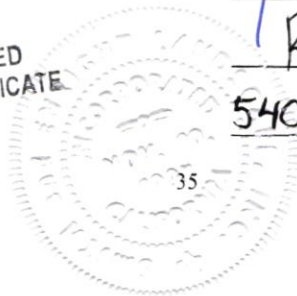

(Attach Notary Acknowledgment)

Contractor (signature in blue ink)

NOTE: Please refer to the "General Instructions to Low Bidder" for specific signature requirements.

I hereby approved the form of the foregoing Contract this 3rd day of August, 2021.

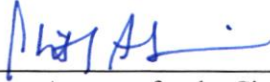

Attorney for the City of Salinas

Checked by the City Engineer on 8-4-21



City Engineer

ALL SIGNATURES SHALL BE NOTARIZED EXCEPT THOSE OF CITY OFFICIALS

CALIFORNIA ALL-PURPOSE CERTIFICATE OF ACKNOWLEDGMENT

A notary public or other officer completing this certificate verifies only the identity of the individual who signed the document to which this certificate is attached, and not the truthfulness, accuracy, or validity of that document

State of California
County of Monterey

On July 15, 2021 before me, Vanessa Paradise, Notary Public
personally appeared Richard A. Enright

who proved to me on the basis of satisfactory evidence to be the person(s) whose name(s) is/are subscribed to the within instrument and acknowledged to me that he/she/they executed the same in his/her/their authorized capacity(ies), and that by his/her/their signature(s) on the instrument the person(s), or the entity upon behalf of which the person(s) acted, executed the instrument.



NOTARY SEAL

I certify under PENALTY OF PERJURY under the laws of the State of California that the foregoing paragraph is true and correct.

WITNESS my hand and official seal.

Signature Van Paradise
Signature of Notary Public

ADDITIONAL OPTIONAL INFORMATION

Title or Description of attached document: Invitation to Bid -

Document Date: No Date Number of Pages: -103-

Capacity(ies) Claimed by Signer
Signer's Name: _____
 Individual
 Corporate Officer
 Partner
 Attorney-in-Fact
 Trustee
 Other: _____
Signer is representing _____

Capacity(ies) Claimed by Signer
Signer's Name: _____
 Individual
 Corporate Officer
 Partner
 Attorney-in-Fact
 Trustee
 Other: _____
Signer is representing _____

2060437

A0762934

FILED
Secretary of State
State of California

NOV 07 2014

CERTIFICATE OF AMENDMENT OF
ARTICLES OF INCORPORATION OF
SMITH and ENRIGHT LANDSCAPE, INC.

JAMES F. SMITH and RICHARD A. ENRIGHT certify that:

1. They are the President, Secretary and Chief Financial Officer, respectively, of SMITH and ENRIGHT LANDSCAPE, INC., a California corporation.
2. The Board of Directors of SMITH and ENRIGHT LANDSCAPE, INC. has approved the following amendments to the Articles of Incorporation:
3. ARTICLE I: NAME of the Articles of Incorporation is amended to read as follows:

I. NAME

The name of the corporation is SMITH & ENRIGHT LANDSCAPING, INC.

4. The following shall be added as Article VIII of the Articles of Incorporation:

VIII. CLOSE CORPORATION

The corporation's issued shares of all classes will be held of record by not more than 35 persons. This corporation is a close corporation.

5. These amendments have been approved by the required vote of the shareholders in accordance with Corporations Code Section 902. The corporation has only one class of shares. Each outstanding share is entitled to one vote. The total number of shares issued and outstanding is 1,600 shares. Corporations Code Section 158(b) requires a unanimous vote of all outstanding shares for the adoption of these amendments. The number of shares voting in favor of the amendment equaled the vote required; the amendment was approved by the affirmative vote of 1,600 shares, that is, by the affirmative vote of one hundred percent (100%) of all the issued and outstanding shares.

We declare under penalty of perjury that the statements set forth in this certificate are true and correct of our own knowledge and that this declaration was executed on November 4, 2014 at Salinas, California.

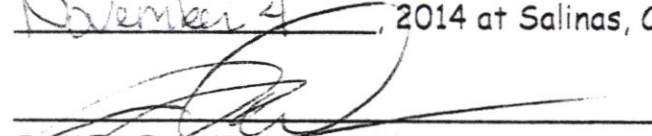

JAMES F. SMITH, President



RICHARD A. ENRIGHT, Secretary
and Chief Financial Officer

State of California

SECRETARY OF STATE

I, *BILL JONES*, Secretary of State of the State of California, hereby certify:

That the attached transcript has been compared with the record on file in this office, of which it purports to be a copy, and that it is full, true and correct.

IN WITNESS WHEREOF, I execute this certificate and affix the Great Seal of the State of California this



Bill Jones

Secretary of State

ARTICLES OF INCORPORATION
OF
SMITH and ENRIGHT LANDSCAPE, INC.

ENDORSED
FILED
the office of the Secretary of State
of the State of California

NOV 10 1997

Bill Jones
BILL JONES, Secretary of State

I. NAME

The name of the corporation is SMITH and ENRIGHT LANDSCAPE,
INC.

II. PURPOSE

The purpose of this corporation is to engage in any lawful act or activity for which a corporation may be organized under the General Corporation Law of California other than the banking business, the trust company business, or the practice of a profession permitted to be incorporated by the California Corporation Code.

III. DIRECTORS

The number of Directors of the corporation is two (2).

IV. INITIAL DIRECTORS

The names and addresses of the persons appointed to act as initial
Directors are:

Richard A. Enright
16 Hitchcock Road
Salinas, CA 93908

James F. Smith
16 Hitchcock Road
Salinas, CA 93908

DECLARATION

We declare that we are the persons who executed the above Articles of Incorporation and that this instrument is our act and deed.

Richard A. Enright DIRECTOR

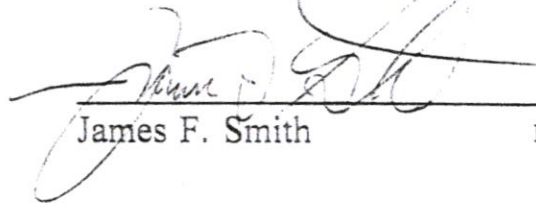
James F. Smith DIRECTOR



PUBLIC WORKS CONTRACT AWARD INFORMATION (D.A.S. 140)

PUBLIC WORKS CONTRACT AWARD INFORMATION

Contract award information must be sent to your Apprenticeship Committee if you are approved to train. If you are not approved to train, you must send the information (which may be this form) to ALL applicable Apprenticeship Committees in your craft or trade in the area of the site of the public work. Go to: <http://www.dir.ca.gov/das/PublicWorksForms.htm> for information about programs in your area and trade. You may also consult your local Division of Apprenticeship Standards (DAS) office whose telephone number may be found in your local directory under California, State of, Industrial Relations, Division of Apprenticeship Standards.

Do not send this form to the Division of Apprenticeship Standards.

NAME OF YOUR COMPANY	CONTRACTOR'S STATE LICENSE NO
MAILING ADDRESS- NUMBER & STREET, CITY, ZIP CODE	AREA CODE & TELEPHONE NO.
NAME & ADDRESS OF PUBLIC WORKS PROJECT	DATE YOUR CONTRACT EXECUTED
	DATE OF EXPECTED OR ACTUAL START OF PROJECT
NAME & ADDRESS OF PUBLIC AGENCY AWARDDING CONTRACT	ESTIMATED NUMBER OF JOURNEYMEN HOURS
	OCCUPATION OF APPRENTICE
THIS FORM IS BEING SENT TO: (NAME & ADDRESS OF APPRENTICESHIP PROGRAM(S))	ESTIMATED NUMBER OF APPRENTICE HOURS
	APPROXIMATE DATES TO BE EMPLOYED

This is not a request for dispatch of apprentices.

Contractors must make a separate request for actual dispatch, in accordance with Section 230.1(a) California Code of Regulations

Check One Of The Boxes Below

1. We are already approved to train apprentices by the _____ Apprenticeship Committee. We will employ and train under their Standards. Enter name of the Committee
2. We will comply with the standards of _____ Apprenticeship Committee for the duration of this job only. Enter name of the Committee
3. We will employ and train apprentices in accordance with the California Apprenticeship Council regulations, including § 230.1 (c) which requires that apprentices employed on public projects can only be assigned to perform work of the craft or trade to which the apprentice is registered and that the apprentices must at all times work with or under the direct supervision of journeyman/men.

Signature _____ Date _____

Typed Name _____

Title _____

**State of California - Department of Industrial Relations DIVISION
OF APPRENTICESHIP STANDARDS**

City reserves the right to modify these requirements, including limits, based on the nature of the risk, prior experience, insurer, coverage, or other special circumstance.

2. For any claims related to this project, the **Contractor's insurance coverage shall be primary** insurance coverage at least as broad as ISO CG 20 01 04 13 as respects the City, its officers, officials, employees, and volunteers. Any insurance or self-insurance maintained by the City, its officers, officials, employees, or volunteers shall be excess of the Contractor's insurance and shall not contribute with it.

3. Each insurance policy required by this clause shall provide that coverage shall not be canceled, except with notice to the City.

4. A copy of the claims reporting requirements must be submitted by Contractor to the City.

5. If the services involve lead-based paint or asbestos identification/remediation, the Contractor's Pollution Liability policy shall not contain lead-based paint or asbestos exclusions. If the services involve mold identification/remediation, the Contractor's Pollution Liability policy shall not contain a mold exclusion, and the definition of Pollution shall include microbial matter, including mold.

Acceptability of Insurers

Insurance is to be placed with insurers authorized to conduct business in the state with a current A.M. Best rating of no less than A: VII, unless otherwise acceptable to the City.

Waiver of Subrogation

Contractor hereby agrees to waive rights of subrogation which any insurer of Contractor may acquire from Contractor by virtue of the payment of any loss. Contractor agrees to obtain any endorsement that may be necessary to affect this waiver of subrogation. The Workers' Compensation policy shall be endorsed with a waiver of subrogation in favor of the City for all work performed by the Contractor, its employees, agents and subcontractors.

Verification of Coverage

Contractor shall furnish the City with original Certificates of Insurance including an additional insured endorsement and all required amendatory endorsements (or copies of the applicable policy language effecting coverage required by this clause) and a copy of the Declarations and Endorsement Page of the CGL policy listing all policy endorsements to City before work begins. However, failure to obtain the required documents prior to the work beginning shall not waive the Contractor's obligation to provide them. The City reserves the right to require complete, certified copies of all required insurance policies, including endorsements, required by these specifications, at any time.

Subcontractors

Contractor shall require and verify that all subcontractors maintain insurance meeting all the requirements stated herein, and Contractor shall ensure that City is an additional insured on insurance required from subcontractors. For CGL coverage subcontractors shall provide coverage with a form at least as broad as CG 20 38 04 13.

Maintenance of Insurance

Maintenance of insurance by Contractor as specified shall in no way be interpreted as relieving Contractor of its indemnification obligations or any responsibility whatsoever and the Contractor may carry, at its own expense, such additional insurance as it deems necessary.

Special Risks or Circumstances

INSURANCE REQUIREMENTS

Contractor shall procure and maintain for the duration of the contract, and for three years thereafter, insurance against claims for injuries to persons or damages to property which may arise from or in connection with the performance of the work hereunder by the Contractor, his/her/its officers, agents, representatives, employees, and/or subcontractors.

MINIMUM SCOPE AND LIMIT OF INSURANCE

Coverage shall be at least as broad as:

1. **Commercial General Liability** (“CGL”): Insurance Services Office (“ISO”) Form CG 00 01 covering CGL on an occurrence basis, including products and completed operations, property damage, bodily injury and personal & advertising injury with limits no less than **\$2,000,000** per occurrence. If a general aggregate limit applies, either the general aggregate limit shall apply separately to this project/location (ISO Form CG 25 03 or 25 04) or the general aggregate limit shall be twice the required occurrence limit.
2. **Automobile Liability**: ISO Form CA 0001 covering Code 1 (any auto), with limits no less than **\$1,000,000** per accident for bodily injury and property damage.
3. **Workers’ Compensation**: as required by the State of California, with Statutory Limits, and Employers’ Liability insurance with a limit of no less than \$1,000,000 per accident for bodily injury or disease.
4. **Contractors’ Pollution Legal Liability and/or Asbestos Legal Liability and/or Errors and Omissions** (if project involves environmental hazards): with limits no less than \$1,000,000 per occurrence or claim, and \$2,000,000 policy aggregate, on an annual basis.

If the Contractor maintains broader coverage and/or higher limits than the minimums shown above, the Contractor requires and shall be entitled to the broader coverage and/or higher limits maintained by the Contractor. Any available insurance proceeds in excess of the specified minimum limits of insurance and coverage shall be available to the City

Self-Insured Retention

Self-insured retentions must be declared to and approved by the City. At the option of the City, either: the Contractor shall cause the insurer shall to reduce or eliminate such self-insured retentions as respects the City, its officers, officials, employees, and volunteers; or the Contractor shall provide a financial guarantee satisfactory to the City guaranteeing payment of losses and related investigations, claim administration, and defense expenses. The policy language shall provide, or be endorsed to provide, that the self-insured retention may be satisfied by either the named insured or City.

Other Insurance Provisions

The insurance policies are to contain, or be endorsed to contain, the following provisions:

1. **The City, its officers, officials, employees, and volunteers are to be covered as additional insureds** on the CGL policy with respect to liability arising out of work or operations performed by or on behalf of the Contractor including materials, parts, or equipment furnished in connection with such work or operations and automobiles owned, leased, hired, or borrowed by or on behalf of the Contractor. General liability coverage can be provided in the form of an endorsement to the Contractor’s insurance (at least as broad as ISO Form CG 20 10, CG 11 85 or **both** CG 20 10, CG 20 26, CG 20 33, or CG 20 38; **and** CG 20 37 forms if later revisions used).

THIS ENDORSEMENT CHANGES THE POLICY. PLEASE READ IT CAREFULLY.

BLANKET ADDITIONAL INSURED

This endorsement modifies insurance provided under the following:

BUSINESS AUTO COVERAGE FORM
 AUTO DEALERS COVERAGE FORM
 MOTOR CARRIER COVERAGE FORM

A. Who Is an Insured (SECTION II - LIABILITY COVERAGE, paragraph A.1.) is amended to include as an insured any person or organization (called additional Insured) with respect to the operation, maintenance, or use of a covered "auto" whom you are required to add as an additional Insured on this Policy under:

1. a written contract or agreement, or;
2. an oral contract or agreement where a certificate of insurance showing that person or organization as an additional Insured has been issued;

but the written or oral contract must be:

- a. currently in effect or becoming effective during the term of this Policy; and
- b. executed prior to the date of "loss."

B. If the additional Insured is a lessor of a "leased auto";

1. Coverage

- a. Any "leased auto" designated or described in the Schedule will be considered a covered "auto" you own and not a covered "auto" you hire or borrow.

For a covered "auto" that is a "leased auto" Who Is An Insured is changed to include as an "Insured" the lessor.

- b. The coverages provided under this endorsement apply to any "leased auto" described in the Schedule until the expiration date shown in the Schedule, or when the lessor or his or her agent takes possession of the "leased auto," whichever occurs first.

2. Loss Payable Clause

- a. We will pay, as interest may appear, you and the lessor for "loss" to a "leased auto."
- b. The insurance covers the interest of the lessor unless the "loss" results from fraudulent acts or omissions on your part.
- c. If we make any payment to the lessor, we will obtain his or her rights against any other party.

3. Cancellation

- a. If we cancel the Policy, we will mail notice to the lessor in accordance with the Cancellation Common Policy Condition.
- b. If you cancel the Policy, we will mail notice to the lessor.
- c. Cancellation ends this agreement.

4. The lessor is not liable for payment of your premiums.

5. Additional Definition

As used in this endorsement:

"Leased auto" means an "auto" leased or rented to you including any substitute, replacement or extra "auto" needed to meet seasonal or other needs, under a leasing or rental agreement that requires you to provide direct primary insurance for the lessor.

THIS ENDORSEMENT CHANGES THE POLICY. PLEASE READ IT CAREFULLY.

PRIMARY AND NONCONTRIBUTORY - OTHER INSURANCE CONDITION

This endorsement modifies insurance provided under the following:

COMMERCIAL GENERAL LIABILITY COVERAGE PART
PRODUCTS/COMPLETED OPERATIONS LIABILITY COVERAGE PART

The following is added to the **Other Insurance** Condition and supersedes any provision to the contrary:

Primary and Noncontributory Insurance

This insurance is primary to and will not seek contribution from any other insurance available to an additional insured under your policy provided that:

- (1) the Additional Insured is a Named Insured under such other insurance; and
- (2) you have agreed in writing in a contract or agreement that this insurance would be primary and would not seek contribution from any other insurance available to the Additional Insured.

Copyright, ISO Properties, Inc., 2012

THIS ENDORSEMENT CHANGES THE POLICY. PLEASE READ IT CAREFULLY.

**AUTOMATIC ADDITIONAL INSURED - WHEN REQUIRED IN CONTRACT
OR AGREEMENT WITH YOU**

This endorsement modifies insurance provided under the following:

COMMERCIAL GENERAL LIABILITY COVERAGE PART

A. SECTION II. - WHO IS AN INSURED, 2. is amended to include as an insured any person or organization who you are required to add as an additional insured on this Policy under:

1. a written contract or agreement; or
2. an oral agreement or contract where a certificate of insurance showing that person or organization as an additional insured has been issued;

but the written or oral contract or agreement must be:

- a. currently in effect or becoming effective during the term of this Policy; and
- b. executed prior to the "bodily injury," "property damage," or "personal and advertising injury."

However:

- 1) the insurance afforded to such additional insured only applies to the extent permitted by law; and
- 2) if coverage provided to the Additional Insured is required by a contract or agreement, the insurance afforded to such additional insured will not be broader than that which you are required by the contract or agreement to provide for such additional insured.

B. The insurance provided to the Additional Insured person or organization applies only to "bodily injury," "property damage" or "personal

or advertising injury" covered under **SECTION I - COVERAGE A - Bodily Injury and Property Damage** and **SECTION I - COVERAGE B - Personal and Advertising Injury**, but only with respect to liability for "bodily injury," "property damage" or "personal and advertising injury" caused, in whole or in part, by:

1. your acts or omissions; or
2. the acts or omissions of those acting on your behalf; and resulting directly from:
 - a. your ongoing operations performed for the Additional Insured, which is the subject of the written or oral contract or agreement; or
 - b. "your work" completed as included in the "products-completed operations hazard," performed for the Additional Insured, which is the subject of the written or oral contract or agreement.

C. However, regardless of the provisions of paragraph **A.** and **B.** above:

1. We will not extend any insurance coverage to any additional insured person or organization:
 - a. that is not provided to you in this coverage part; or
 - b. that is any broader coverage than you are required to provide to the Additional Insured person or organization in the written or oral contract or agreement; and

2. With respect to the insurance afforded to these Additional Insured, the following is added to **SECTION III - LIMITS OF INSURANCE**:

If coverage provided to the Additional Insured is required by a contract or agreement, the most we will pay on behalf of the Additional Insured is the amount of insurance:

- a. required by the contract or agreement; or
- b. available under the applicable Limits of Insurance shown in the Declarations; whichever is less.

This endorsement shall not increase the applicable Limits of Insurance shown in the Declarations.

- D. The insurance provided to the Additional Insured person or organization does not apply to "bodily injury," "property damage," or "personal and advertising injury" arising out of the rendering or failure to render any professional architectural, engineering or surveying services, including:

1. the preparing, approving or failing to prepare or approve maps, shop drawings, opinions, reports, surveys, field orders, change orders or drawings or specifications; and
2. supervisory, inspection, architectural or engineering services.

- E. The Additional Insured must see to it that:

1. we are notified as soon as practicable of an "occurrence" or offense that may result in a claim;
2. we receive written notice of a claim or "suit" as soon as practicable; and
3. a request for defense and indemnity of the claim or "suit" will promptly be brought against any policy issued by another insurer under which the Additional Insured may be an insured in any capacity. This provision does not apply to insurance on

which the Additional Insured is a named insured, if the written or oral contract or agreement requires that this coverage be primary and non-contributory.

- F. For the coverage provided by this endorsement:

1. The following paragraph is added to paragraph 4.a. of the Other Insurance Condition of **SECTION IV - COMMERCIAL GENERAL LIABILITY CONDITIONS**: This insurance is primary insurance as respects our coverage to the Additional Insured person or organization, where the written contract or agreement requires that this insurance be primary and non-contributory. In that event, we will not seek contribution from any other insurance policy available to the Additional Insured on which the Additional Insured person or organization is a named insured.

2. The following paragraph is added to paragraph 4.b. of the Other Insurance Condition of **SECTION IV - COMMERCIAL GENERAL LIABILITY CONDITIONS**:

This insurance is excess over:

Any of the other insurance, whether primary, excess, contingent or on any other basis, available to an additional insured, in which the Additional Insured on our policy is also covered as an additional insured by attachment of an endorsement to another policy providing coverage for the same "occurrence," claim or "suit." This provision does not apply to any policy in which the Additional Insured is a named insured on such other policy and where our policy is required by written contract or agreement, executed prior to the date of loss, specifically requires that this insurance provide coverage to the Additional Insured on a primary or non-contributory basis.

- G. This endorsement does not apply to an additional insured which has been added to this Policy by an endorsement showing the Additional Insured in a Schedule of additional insureds, and which endorsement applies specifically to that identified additional insured.

This endorsement does not change any other provision of the Policy.

THIS ENDORSEMENT CHANGES THE POLICY. PLEASE READ IT CAREFULLY.

**CONTRACTORS PLUS
COMMERCIAL GENERAL LIABILITY ENDORSEMENT**

This endorsement modifies the insurance provided under the following:

COMMERCIAL GENERAL LIABILITY COVERAGE PART

The following is a summary of the Limits of Insurance and additional coverages provided by this endorsement. For complete details on specific coverages, consult the policy contract wording.

A. The Limits of Insurance shown below are provided for the Coverages listed:

Limits	Subjects of Insurance
\$ 1,000	Bail Bonds
\$ 300,000	Damage to Premise Rented to You
\$ 10,000	Medical Payments

B. The following coverage extensions are provided. These are extensions of coverage, not additional Limits of Insurance.

Automatic Additional Insured when required in Construction Agreement
 Broad Named Insured
 Broad Notice of Occurrence
 Broadened Mobile Equipment
 Contractual Personal Injury and Advertising Injury
 Incidental Malpractice Liability
 Mental Anguish
 Newly Formed or Acquired Organizations
 Non-owned aircraft
 Non-owned watercraft up to 51 feet
 Per Location/Per Project Aggregate Limit
 Personal Injury Definition Amendment
 Property Damage - Borrowed Equipment
 Property Damage - Elevators
 Unintentional Failure to Disclose Hazards

Includes copyrighted material of ISO Properties, Inc., with its permission.

I. The **Commercial General Liability Coverage Part** is amended as follows:

A. SECTION I - COVERAGES

1. Coverage A **Bodily Injury and Property Damage Liability**

a. Exclusions

- (1) Exclusion **g. Aircraft, Auto or Watercraft**, is deleted in its entirety and replaced by the following:

g. Aircraft, Auto or Watercraft

"Bodily injury" or "property damage" arising out of the ownership, maintenance, use or entrustment to others of any aircraft, "auto" or watercraft owned or operated by or rented or loaned to any insured. Use includes operation and "loading or unloading."

This exclusion applies even if the claims against any insured allege negligence or other wrongdoing in the supervision, hiring, employment, training or monitoring of others by that Insured, if the "occurrence" which caused the "bodily injury" or "property damage" involved the ownership, maintenance, use or entrustment to others of any aircraft, "auto" or watercraft that is owned or operated by or rented or loaned to any insured.

This exclusion does not apply to:

- (1) an aircraft, with a paid crew, that is hired, chartered or loaned but is not owned by any insured;
- (2) a watercraft while ashore or at premises you own or rent;
- (3) a watercraft you do not own and that is:
 - (a) less than 51 feet long; and
 - (b) not being used to carry persons or property for a charge;
- (4) parking an "auto" on, or on the ways next to, premises you own or rent, provided the "auto" is not owned by or rented or loaned to you or the Insured;
- (5) liability assumed under any "insured contract" for the ownership, maintenance or use of aircraft or watercraft; or
- (6) "bodily injury" or "property damage" arising out of:
 - (a) the operation of machinery or equipment that is attached to, or part of, a land vehicle that would qualify under the definition of "mobile"

equipment" if it were not subject to a compulsory or financial responsibility law or other motor vehicle insurance law in the state where it is licensed or principally garaged; or

(b) the operation of any of the machinery or equipment listed in paragraph f.(2) or f.(3) of the definition of "mobile equipment."

(2) Exclusion j. **Damage to Property** is deleted in its entirety and is replaced with the following:

j. Damage to Property

"Property damage" to:

- (1) property you own, rent, or occupy, including any costs or expenses incurred by you, or any other person, organization or entity, for repair, replacement, enhancement, restoration or maintenance of such property for any reason, including prevention of injury to a person or damage to another's property;
- (2) premises you sell, give away or abandon, if the

"property damage" arises out of any part of those premises;

- (3) property loaned to you;
- (4) personal property in the care, custody or control of the Insured;
- (5) that particular part of real property on which you or any contractors or subcontractors working directly or indirectly on your behalf are performing operations, if the "property damage" arises out of those operations;
- (6) that particular part of any property that must be restored, repaired, or replaced because "your work" was incorrectly performed on it.

Paragraph (2) of this exclusion does not apply if the premises are "your work" and were not occupied, rented or held for rental by you.

Paragraphs (3), (4), (5) and (6) of this exclusion do not apply to liability assumed under a sidetrack agreement.

Paragraphs (3) and (4) of this exclusion do not apply to the use of elevators.

Paragraph (4) of this exclusion does not apply to "property damage" to borrowed equipment while not being used to perform operations at a job site.

Paragraph (6) of this exclusion does not apply to "property damage" included in the "products -completed operations hazard."

- (3) The last paragraph in **2. Exclusions** is deleted in its entirety and replaced by the following:

Exclusions **c.** through **n.** do not apply to damage by fire, lightning or "explosion" to premises while rented to you or temporarily occupied by you with permission of the owner. A separate Limit of Insurance applies to this coverage as described in **Limit of Insurance (Section III)**.

2. Coverage B Personal Injury and Advertising Injury Liability

a. 2. Exclusions

Exclusion **e.** is deleted in its entirety.

3. Coverage C Medical Payments

Paragraph **1.a.** of the Insuring Agreement is deleted in its entirety and replaced by the following:

- a.** We will pay medical expenses as described below for "bodily injury" caused by an accident:

- (1) on premises you own or rent;
- (2) on ways next to premises you own or rent; or
- (3) because of your operations;

provided that:

- (1) the accident takes place in the "coverage territory" and during the policy period;

- (2) the expenses are incurred and reported to us within three years of the date of the accident; and

- (3) the injured person submits to examination, at our expense, by physicians of our choice as often as we reasonably require.

4. Supplementary Payments - Coverages A and B

Item **1.b.** is deleted in its entirety and replaced by the following:

- b.** Up to \$1,000 for cost of bail bonds required because of accidents or traffic law violations arising out of the use of any vehicle to which the Bodily Injury Liability Coverage applies. We do not have to furnish these bonds.

B. SECTION II - WHO IS AN INSURED

1. Item **2.a.(1)(d)** is deleted in its entirety and replaced with the following:

- (d) Arising out of his or her providing or failing to provide professional health care services. However, this exclusion does not apply to nurses, emergency medical technicians or paramedics who are employed by you to provide medical or paramedical services.

2. Items **2.e.** and **2.f.** are added:

- e.** Any subsidiary and subsidiary thereof, of yours which is a legally incorporated entity of which you own a financial interest of more than 50% of voting stock on the effective date of this Coverage Part. The insurance afforded herein for any subsidiary not named in this Coverage Part as a named insured does not apply to injury or damage with respect to which an insured under this Coverage Part is also an insured under another policy or would be an insured under such

Includes copyrighted material of ISO Properties, Inc., with its permission.

policy but for its termination or the exhaustion of its Limits of Insurance.

- f. Any person or organization for whom you are performing operations when you and such person or organization have agreed in writing in a contract or agreement that such person or organization be added as an additional insured on your policy. Such person or organization is an additional insured only with respect to liability arising out of your ongoing operations performed for that Insured but

(1) coverage is no broader than coverage provided to you under this policy, and

(2) only to the extent of the applicable Limit of Insurance of this policy.

A person's or organization's status as an insured under this endorsement ends when your operations for that Insured are completed.

The insurance provided the Additional Insured(s) is limited to liability arising out of acts or omissions of the Additional Insured(s) in connection with their general supervision of "your work."

This insurance does not apply to "bodily injury," "property damage," or "personal and advertising injury" arising out of an architect's, engineer's, or surveyors' rendering or failure to render any professional architectural, engineering or surveying services, including:

- a. the preparing, approving, or failing to prepare or approve maps, shop drawings, opinions report, surveys, field orders, change orders or drawing and specifications; and
- b. supervisory, inspection, architectural or engineering activities.

3. Paragraph 3. is deleted in its entirety and replaced by the following:

3. Any organization you newly acquire or form, other than a partnership, joint venture or limited liability company, and over which you maintain ownership or majority interest, will qualify as a named insured if there is no other similar insurance available to that organization. However:

a. coverage under this provision is afforded only until the 180th day after you acquire or form the organization or the end of the policy period, whichever is earlier;

b. Coverage A does not apply to "bodily injury" or "property damage" that occurred before you acquired or formed the organization;

c. Coverage B does not apply to "personal and advertising injury" arising out of an offense committed before you acquired or formed the organization.

No person or organization is an insured with respect to the conduct of any current or past partnership, joint venture or limited liability company that is not shown as a named insured in the Declarations.

C. SECTION III - LIMITS OF INSURANCE

1. Item 2. is deleted in its entirety and replaced by the following:

2. The General Aggregate Limit is the most we pay for the sum of:

a. medical expenses under Coverage C;

b. damages under Coverage A, except damages because of "bodily injury" or "property

damages" included in the "products-completed operations hazard"; and

c. damages under Coverage B

at any one

- a. project away from premises owned by or rented to you; or
- b. premises owned by or rented to you, involving the same or connecting lots or premises whose connection is interrupted only by a street, roadway, waterway or right-of-way of a railroad.

2. Item 6. is deleted in its entirety and replaced by the following:

- 6. Subject to 5. above, the higher of \$300,000 or the Damage to Premises Rented to You Limit is the most we will pay under Coverage A for damages because of "property damage" to premises while rented to you, or in the case of damage by fire, lightning or "explosion," or temporarily occupied by you with permission of the owner.

3. Item 7. is deleted in its entirety and replaced by the following:

- 7. Subject to 5. above, the most we will pay under Coverage C for all medical expenses because of "bodily injury" sustained by any one person is the higher of \$10,000 or the Medical Expense Limit shown in the Declarations.

D. SECTION IV - COMMERCIAL GENERAL LIABILITY CONDITIONS

1. Item 2. - Duties in the Event of Occurrence, Offense, Claim or Suit - is deleted in its entirety and replaced by the following:

2. Duties in the Event of Occurrence, Offense, Claim or Suit.

- a. You must see to it that we are notified as soon as practicable of an "occurrence" or an offense which may result in a claim. To the extent possible, notice should include:

- (1) how, when and where the "occurrence" or offense took place;
- (2) the names and addresses of any injured persons and witnesses; and
- (3) the nature and location of any injury or damage arising out of the "occurrence" or offense.

- b. If a claim is made or "suit" brought against any insured, you must:

- (1) immediately record the specifics of the claim or "suit" and the date received; and
- (2) notify us as soon as practicable.

You must see to it that we receive written notice of the claim or "suit" as soon as practicable.

- c. You and any other involved insured must:

- (1) immediately send us copies of any demands, notices, summonses or legal papers received in connection with the claim or "suit";
- (2) authorize us to obtain records and other information;
- (3) cooperate with us in the investigation or settlement of the claim or defense against the "suit"; and

- (4) assist us, upon our request, in the enforcement of any right against any person or organization which may be liable to the Insured because of injury or damage to which this insurance may also apply.

- d. No insured will, except at the Insured's own cost, voluntarily make a payment, assume any obligation, or incur any expense, other than for first aid, without our consent.

Knowledge of an "occurrence", claim or "suit" by the agent, servant or employee of any insured shall not in itself constitute knowledge of the Insured unless an officer or his designee shall have received notice from its agent, servant or employee.

- 2. Item 4. - **Other Insurance** is deleted in its entirety and replaced by the following:

4. Other Insurance

- a. If other valid and collectible insurance is available to the Insured for a loss we cover under Coverage **A** or **B** of this Coverage Part, our obligations are limited as follows:

(1) Primary Insurance

This insurance is primary except when (2) below applies. If this insurance is primary, our obligations are not affected unless any of the other insurance is also primary. Then, we will share with all that other insurance by the method described in (3) below.

(2) Excess Insurance

This insurance is excess over:

- (a) Any of the other insurance, whether primary, excess, contingent or on any other basis:

- (i) that is Fire, Extended Coverage, Builder's Risk, Installation Risk or similar coverage for "your work";

- (ii) that is Fire, Lightning, or Explosion insurance for premises rented to you or temporarily occupied by you with permission of the owner;

- (iii) if the loss arises out of the maintenance or use of aircraft, "autos" or watercraft to the extent not subject to exclusion **g.** of Coverage **A (Section I)**;

- (iv) if the loss arises out of "property damage" to borrowed equipment while not being used to perform op-

erations at the job site; or

(v) if the loss arises out of "property damage" due to the use of elevators .

(b) Any other primary insurance available to you covering liability for damages arising out of the premises or operations, or the product and completed operations, for which you have been added as an insured by attachment of an endorsement.

(c) Any other primary insurance available to an automatic additional insured when required in a construction agreement with you covering liability for damages arising out of the premises or operations unless you are specifically required by written contract for this insurance to be primary.

When this insurance is excess, we will have no duty under Coverage **A** or **B** to defend the Insured against any "suit" if any other insurer has a duty to defend the Insured against that "suit." If no other insurer defends, we will undertake to do so, but we

will be entitled to the Insured's rights against all those other insurers.

When this insurance is excess over other insurance, we will pay only our share of the amount of the loss, if any, that exceeds the sum of :

(a) the total amount that all such other insurance would pay for the loss in the absence of this insurance; and

(b) the total of all deductible and self-insured amounts under all that other insurance.

We will share the remaining loss, if any , with any other insurance that is not described in this Excess Insurance provision and was not bought specifically to apply in excess of the Limits of Insurance shown in the Declarations of this Coverage Part.

(3) Method of Sharing

If all of the other insurance permits contribution by equal shares, we will follow this method also. Under this approach, each insurer contributes equal amounts until it has paid its applicable Limit of Insurance or none of the loss remains, whichever comes first.

If any of the other insurance does not permit contribution by equal shares, we will

contribute by limits. Under this method, each insurer's share is based on the ratio of its applicable Limit of Insurance to the total applicable Limits of Insurance of all insurers.

(4) No Insurance

(a) If an insured has any other insurance for "bodily injury" or "property damage" due to non-owned aircraft or non-owned watercraft, the insurance provided by this policy, does not apply.

(b) If a joint venture or partnership that was terminated or ended prior to this policy period has valid and collectible insurance that was purchased specifically for that joint venture or partnership, the insurance provided by this policy does not apply.

b. If other valid and collectible insurance is available to the injured person for a loss we cover under Coverage C of this Coverage Part this insurance is excess over any other insurance, whether primary or excess, contingent or on any other basis.

We will pay only our share of the amount of the loss, if any, that exceeds the total amount that all such other insurance would pay for the loss in the absence of this insurance. We will share the remaining loss, if any, with

any other insurance that is not described in this Excess Insurance provision and was not bought specifically to apply in excess of the Limits of Insurance shown in the Declarations page of this Coverage Part.

3. Item 6. - **Representations** is deleted in its entirety and replaced by the following:

6. Representations

By accepting this policy, you agree:

- a. the statements in the Declarations are accurate and complete;
- b. those statements are based upon representations you made to us; and
- c. we have issued this policy in reliance upon your representations.

However, if unintentionally you should fail to disclose all existing hazards at the inception date of your policy, we shall not deny coverage under this Coverage Part because of such failure.

E. SECTION V - DEFINITIONS

1. Item 3. is deleted in its entirety and replaced with the following:

3. "**Bodily injury**" means bodily injury, sickness, disease or "incidental medical malpractice" sustained by a person, including mental anguish or death resulting from any of these at any time.

2. The following definition is added:

23. "**Incidental medical malpractice**" means injury arising out of the negligent rendering or failure to render medical or paramedical services to persons by any physician, dentist, nurse, emergency medical technician or paramedic who is employed by you

to provide such services provided you are not engaged in the business or occupation of providing any services referred to in this definition.

3. Item 12. - "**Mobile Equipment**" is amended. Item f. is deleted in its entirety and replaced by the following:

12.f. Vehicles not described in a., b., c., or d. above maintained primarily for purposes other than the transportation of persons or cargo.

However, self propelled vehicles with the following types of permanently attached equipment are not "mobile equipment" but will be considered "autos":

(1) equipment designed primarily for:

- (a) snow removal;
- (b) road maintenance, but not construction or resurfacing; or
- (c) street cleaning;

provided that the vehicles have a Gross Vehicle Weight of 1,000 pounds or greater;

(2) cherry pickers and similar devices mounted on automobile or truck chassis and used to raise or lower workers;

(3) air compressors, pumps and generators including spraying, welding, building cleaning, geophysical exploration, lighting and well servicing equipment.

4. Item 14. **Personal and Advertising Injury** is deleted in its entirety and replaced by the following:

14. "**Personal and Advertising Injury**" means injury, including consequential "bodily injury," arising out of one or more of the following offenses:

- a. false arrest, detention or imprisonment;
- b. malicious prosecution;
- c. the wrongful eviction from, wrongful entry into, or invasion of the right of private occupancy of a room, dwelling or premises that a person occupies, committed by or on behalf of the its owner landlord or lessor;
- d. oral or written publication, in any manner, of material that slanders or libels a person or organization or disparages a person's or organization's goods, products or services;
- e. oral or written publication, in any manner, of material that violates a person's right of privacy;
- f. the use of another's advertising idea in your "advertisement";
- g. infringing upon another's copyright, trade dress or slogan in your "advertisement."
- h. discrimination or humiliation that result in injury to the feelings or reputation of a natural person, but only if such discrimination or humiliation is:

(1) not done intentionally by or at the direction of:

- (a) an insured; or
- (b) any "executive officer" director, stockholder, partner or member of the Insured; and

(2) not directly or indirectly related to the employment, prospective employment or termination of employment of any person or persons by any insured.

5. The following definition is added:

24. "**Explosion**" means a sudden release of expanding pressure accompanied

by a noise, a bursting forth of material and evidence of the scattering of debris to locations further than would have resulted by gravity alone.

Explosion does not include any of the following:

(a) artificially generated electrical current including electrical arcing, that disturbs electrical devices, appliances or wires;

(b) rupture or bursting of water pipes;

(c) explosion of steam boilers, steam pipes, steam engines or steam turbines owned or leased by you, or operated under your control; or

(d) rupture or bursting caused by centrifugal force.



Administrative Offices
301 E 4th Street
Cincinnati OH 45202-4201
513 369 5000 ph

Policy# PAC362404800

CG 84 72
(Ed. 01 10)

THIS ENDORSEMENT CHANGES THE POLICY. PLEASE READ IT CAREFULLY.

WAIVER OF TRANSFER OF RIGHTS OF RECOVERY AGAINST OTHERS TO US

This endorsement modifies insurance provided under the following:

COMMERCIAL GENERAL LIABILITY COVERAGE PART
PRODUCTS/COMPLETED OPERATIONS LIABILITY COVERAGE PART

The following is added to paragraph **8. Transfer of Rights of Recovery Against Others to Us of Section IV - Conditions:**

If the Insured waives any right of recovery against any person or organization for all or part of any payment, including supplementary payments, we make under this Policy, we also waive that right, provided the Insured waives such right of recovery against such person or organization in a written contract or written permit executed before the "occurrence," "bodily injury," "property damage," offense, or "personal and advertising injury" that took place.

This endorsement does not change any other provision of the Policy.

CG 84 72 (Ed. 01/10) XS

THIS ENDORSEMENT CHANGES THE POLICY. PLEASE READ IT CAREFULLY.

PRIMARY AND NONCONTRIBUTORY - OTHER INSURANCE CONDITION

This endorsement modifies insurance provided under the following:

AUTO DEALERS COVERAGE FORM
BUSINESS AUTO COVERAGE FORM
MOTOR CARRIER COVERAGE FORM

With respect to coverage provided by this endorsement, the provisions of the Coverage Form apply unless modified by the endorsement.

A. The following is added to the **Other Insurance** Condition in the Business Auto Coverage Form and the **Other Insurance - Primary And Excess Insurance Provisions** in the Motor Carrier Coverage Form and supersedes any provision to the contrary:

This Coverage Form's Covered Autos Liability Coverage is primary to and will not seek contribution from any other insurance available to an "insured" under your policy provided that:

1. Such "insured" is a Named Insured under such other insurance; and
2. You have agreed in writing in a contract or agreement that this insurance would be primary and would not seek contribution from any other insurance available to such "insured".

B. The following is added to the **Other Insurance** Condition in the Auto Dealers Coverage Form and supersedes any provision to the contrary:

This Coverage Form's Covered Autos Liability Coverage and General Liability Coverages are primary to and will not seek contribution from any other insurance available to an "insured" under your policy provided that:

1. Such "insured" is a Named Insured under such other insurance; and
2. You have agreed in writing in a contract or agreement that this insurance would be primary and would not seek contribution from any other insurance available to such "insured".

THIS ENDORSEMENT CHANGES THE POLICY. PLEASE READ IT CAREFULLY.

**WAIVER OF TRANSFER OF RIGHTS OF RECOVERY AGAINST OTHERS TO US
(WAIVER OF SUBROGATION)**

This endorsement modifies insurance provided under the following:

AUTO DEALERS COVERAGE FORM
BUSINESS AUTO COVERAGE FORM
MOTOR CARRIER COVERAGE FORM

With respect to coverage provided by this endorsement, the provisions of the Coverage Form apply unless modified by the endorsement.

Schedule

Name(s) of Person(s) or Organization(s):

Information required to complete this Schedule, if not shown above, will be shown in the Declarations.

The **Transfer of Rights of Recovery Against Others to Us** Condition does not apply to the person(s) or organization(s) shown in the Schedule, but only to the extent that subrogation is waived prior to the "accident" or the "loss" under a contract with that person or organization.



CERTIFICATE OF LIABILITY INSURANCE

DATE (MM/DD/YYYY)
07/16/2021

THIS CERTIFICATE IS ISSUED AS A MATTER OF INFORMATION ONLY AND CONFERS NO RIGHTS UPON THE CERTIFICATE HOLDER. THIS CERTIFICATE DOES NOT AFFIRMATIVELY OR NEGATIVELY AMEND, EXTEND OR ALTER THE COVERAGE AFFORDED BY THE POLICIES BELOW. THIS CERTIFICATE OF INSURANCE DOES NOT CONSTITUTE A CONTRACT BETWEEN THE ISSUING INSURER(S), AUTHORIZED REPRESENTATIVE OR PRODUCER, AND THE CERTIFICATE HOLDER.

IMPORTANT: If the certificate holder is an ADDITIONAL INSURED, the policy(ies) must be endorsed. If SUBROGATION IS WAIVED, subject to the terms and conditions of the policy, certain policies may require an endorsement. A statement on this certificate does not confer rights to the certificate holder in lieu of such endorsement(s).

PRODUCER Newfront Insurance Services, LLC 55 2nd Street Floor 18 San Francisco CA 94105		CONTACT NAME: Lupe Mancinas PHONE (A/C, No, Ext): (415) 754-3635 FAX (A/C, No): E-MAIL ADDRESS: lupe.mancinas@newfront.com	
INSURED Smith & Enright Landscaping, Inc. 540 Work St Ste C Salinas CA 93901		INSURER(S) AFFORDING COVERAGE INSURER A: Service American Indemnity Co NAIC # 39152 INSURER B: INSURER C: INSURER D: INSURER E: INSURER F:	

COVERAGES **CERTIFICATE NUMBER:** **REVISION NUMBER:**

THIS IS TO CERTIFY THAT THE POLICIES OF INSURANCE LISTED BELOW HAVE BEEN ISSUED TO THE INSURED NAMED ABOVE FOR THE POLICY PERIOD INDICATED. NOTWITHSTANDING ANY REQUIREMENT, TERM OR CONDITION OF ANY CONTRACT OR OTHER DOCUMENT WITH RESPECT TO WHICH THIS CERTIFICATE MAY BE ISSUED OR MAY PERTAIN, THE INSURANCE AFFORDED BY THE POLICIES DESCRIBED HEREIN IS SUBJECT TO ALL THE TERMS, EXCLUSIONS AND CONDITIONS OF SUCH POLICIES. LIMITS SHOWN MAY HAVE BEEN REDUCED BY PAID CLAIMS.

INSR LTR	TYPE OF INSURANCE	ADDL INSD	SUBR WVD	POLICY NUMBER	POLICY EFF (MM/DD/YYYY)	POLICY EXP (MM/DD/YYYY)	LIMITS	
	COMMERCIAL GENERAL LIABILITY <input type="checkbox"/> CLAIMS-MADE <input type="checkbox"/> OCCUR GEN'L AGGREGATE LIMIT APPLIES PER: <input type="checkbox"/> POLICY <input type="checkbox"/> PRO-JECT <input type="checkbox"/> LOC OTHER:						EACH OCCURRENCE \$ DAMAGE TO RENTED PREMISES (Ea occurrence) \$ MED EXP (Any one person) \$ PERSONAL & ADV INJURY \$ GENERAL AGGREGATE \$ PRODUCTS - COMP/OP AGG \$ \$	
	AUTOMOBILE LIABILITY <input type="checkbox"/> ANY AUTO <input type="checkbox"/> ALL OWNED AUTOS <input type="checkbox"/> SCHEDULED AUTOS <input type="checkbox"/> HIRED AUTOS <input type="checkbox"/> NON-OWNED AUTOS						COMBINED SINGLE LIMIT (Ea accident) \$ BODILY INJURY (Per person) \$ BODILY INJURY (Per accident) \$ PROPERTY DAMAGE (Per accident) \$ \$	
	UMBRELLA LIAB <input type="checkbox"/> OCCUR EXCESS LIAB <input type="checkbox"/> CLAIMS-MADE DED RETENTION \$						EACH OCCURRENCE \$ AGGREGATE \$ \$	
A	WORKERS COMPENSATION AND EMPLOYERS' LIABILITY ANY PROPRIETOR/PARTNER/EXECUTIVE OFFICER/MEMBER EXCLUDED? (Mandatory in NH) If yes, describe under DESCRIPTION OF OPERATIONS below	Y/N	N/A	X	SAAWC0000133-00	10/01/2020	10/01/2021	<input checked="" type="checkbox"/> PER STATUTE <input type="checkbox"/> OTH-ER E.L. EACH ACCIDENT \$ 1,000,000 E.L. DISEASE - EA EMPLOYEE \$ 1,000,000 E.L. DISEASE - POLICY LIMIT \$ 1,000,000

DESCRIPTION OF OPERATIONS / LOCATIONS / VEHICLES (ACORD 101, Additional Remarks Schedule, may be attached if more space is required)
 RE: MONTE BELLA MAINTENANCE
 A waiver of subrogation in favor of The City, its officers, officials, employees, and volunteers applies to Worker's Compensation.

CERTIFICATE HOLDER **CANCELLATION**

City of Salinas 200 Lincoln Ave Salinas CA 93901	SHOULD ANY OF THE ABOVE DESCRIBED POLICIES BE CANCELLED BEFORE THE EXPIRATION DATE THEREOF, NOTICE WILL BE DELIVERED IN ACCORDANCE WITH THE POLICY PROVISIONS. AUTHORIZED REPRESENTATIVE 
--	--

© 1988-2014 ACORD CORPORATION. All rights reserved.

WAIVER OF OUR RIGHT TO RECOVER FROM OTHERS ENDORSEMENT-CALIFORNIA

We have the right to recover our payments from anyone liable for an injury covered by this policy. We will not enforce our right against the person or organization named in the Schedule. (This agreement applies only to the extent that you perform work under a written contract that requires you to obtain this agreement from us.)

You must maintain payroll records accurately segregating the remuneration of your employees while engaged in the work described in the Schedule.

The additional premium for this endorsement shall be 2.5% of the California workers' compensation premium otherwise due on such remuneration.

Schedule

Person or Organization

Blanket Waiver of Subrogation

Job Description

As respects to all CA jobs performed by the named insured during the policy period where by written contract a waiver of subrogation is required prior to the commencement of work.

This endorsement changes the policy to which it is attached and is effective on the date issued unless otherwise stated
(The information below is required only when this endorsement is issued subsequent to preparation of the policy.)

Endorsement Effective 10-01-2020
Insured
Smith and Enright Landscaping, Inc.(a Corp)

Policy No. SAAWC0000133-00
Insurance Company
Service American Indemnity Company

Endorsement No.

Countersigned By _____

©1998 by the Workers' Compensation Insurance Rating Bureau of California. All rights reserved.

**PART C –
CITY OF SALINAS FORMS AND MEMORANDUM
DOCUMENTS**

INSTRUCTIONS FOR PREPARATION OF STATEMENT OF COMPLIANCE

This statement of compliance meets needs of state and federal payroll requirements to pay fringe benefits in addition to payment of the minimum rates. The Contractor's obligation to pay fringe benefits may be met by payment of the fringes to the various pre-approved Plans, funds, or programs or by making these payments directly to the employees as part of their weekly wage payments.

The Contractor shall show on the face of his or her payroll all monies paid to the employees whether as basic rates or total hourly wage amount in lieu of fringes. The Contractor shall report in the statement of compliance that he or she is paying to others fringes required by the Contract and not paid directly to the employees in lieu of fringes. Detailed instructions follow:

Contractors who pay all required fringe benefits:

A Contractor who pays fringe benefits to approved Plans, funds, or programs in amounts not less than were determined in the applicable wage decisions shall continue to show on the face of his or her payroll the basic hourly rate and overtime rate paid to his or her employees, just as he or she has always done. Such a Contractor shall check paragraph 4(a) of the statement to indicate that he or she is also paying to approved Plans, funds, or programs within the times required for receipt of those sums not less than the amount predetermined as fringe benefits for each craft. Any exception shall be noted on Section 4(c).

Contractors who pay no fringe benefits:

A Contractor who does not pay fringe benefits to an approved Plan shall pay a like amount to the employee. This payment can be reported by inserting in the straight time hourly rate column of his or her payroll an amount not less than the predetermined rate for each classification plus the amount of fringe benefits determined for each classification in the applicable wage decision. Inasmuch as it is not necessary to pay time and a half on wages paid in lieu of fringes, the overtime rate shall be not less than one and one-half the basic predetermined rate plus the required cash in lieu of fringes at the straight time rate. To simplify computation of overtime, the straight time basic rate and payment in lieu of fringes be separately stated in the hourly rate column, thus \$14.56/5.11. In addition, the Contractor shall check paragraph 4(b) of the statement to indicate that he or she is paying fringe benefits directly to his or her employees. Any exceptions shall be noted in Section 4(c).

Use of Section 4(c), Exceptions:

Any Contractor who is making payment to approved Plans, funds, or programs in amounts less than the wage determination requires if obligated to pay the deficiency directly to the employees as wages in lieu of fringes.

Any exceptions to Section 4(a) and 4(b), whichever the Contractor may check shall be entered in Section 4(c). Enter in the Exception column the craft and enter in the Explanation column the hourly amount paid the employees as wages in lieu of fringes and the hourly amount paid to Plans, funds, or programs as fringes.

STATE OF CALIFORNIA • DEPARTMENT OF TRANSPORTATION
STATEMENT OF COMPLIANCE
 CEM-2503 (REV 8/96)

CONTRACTOR/SUBCONTRACTOR	CONTRACT NUMBER
FIRST DAY AND DATE OF PAY PERIOD	LAST DAY AND DATE OF PAY PERIOD

I do hereby certify under penalty of perjury:

- (1) That I pay or supervise payment to employees of the above-referenced contractor on the above-referenced contract. All persons employed on said project for the above-referenced time period have been paid their full weekly wages earned, that no rebates have been or will be made either directly or indirectly to or on behalf of said contractor from the full weekly wages earned by any person and that no deductions have been made either directly or indirectly from the full wages earned by any person other than permissible deductions.
- (2) That any payrolls otherwise under this control required to be submitted for the above period are correct and complete; that the wage rates for laborers or mechanics contained therein are not less than the applicable wages rates:
 - (a) Specified in the applicable wage determination incorporated into the contract;
 - (b) Determined by the Director of Industrial Relations for the county or counties in which the work is performed; that the classification set forth therein for each laborer or mechanic conform with the work he or she performed.
- (3) That any apprentices employed in the above period are duly registered in a bona fide apprenticeship program registered with a State apprenticeship agency.
- (4) That fringe benefits as listed in the contract:
 - (a) Have been or will be paid to the approved plan(s), fund(s), or program(s) for the benefit of listed employee(s), except as noted below.
 - (b) Have been paid directly to the listed employee(s), except as noted below.
 - (c) See exceptions noted below.

EXCEPTION CRAFT	EXPLANATION

REMARKS:

NAME (PLEASE PRINT.)	TITLE
SIGNATURE	DATE

On federally-funded projects, permissible deductions are defined in Regulation, Part 3 (29 CFR, Subtitle A), issued by the Secretary of Labor under the Copland Act, as amended (48 Stat. 948 63 Stat. 108,72 State. 967:76 Stat 357:40 U. S. C. 276c).

Also, the willful falsification of any of the above statements may subject the contractor or subcontractor to civil or criminal prosecution (See Section 1001 of Title 18 and Section 231 of Title 31 of the United States Code).

ADA Notice For individuals with sensory disabilities, this document is available in alternate formats. For information call (916) 263-2041 or TDD (916) 263-2044 or write Records and Forms Management, 1120 N Street, MS-89, Sacramento, CA 95814.

CEM2503





CITY OF SALINAS FRINGE BENEFIT STATEMENT

CONTRACTOR OR SUBCONTRACTOR (Please Print)		CONTRACT NUMBER	DATE
DEPARTMENT OF INDUSTRIAL REGISTRATION NUMBER	CONTRACTORS STATE LICENSE BOARD NUMBER	FEDERAL-AID PROJECT NUMBER	
TO: RESIDENT ENGINEER OR DISTRICT LABOR COMPLIANCE OFFICER		BUSINESS ADDRESS	

Labor Compliance uses the following fringe benefits information (shown or referenced on wage rate determinations) paid to or on behalf of employees in various crafts or classifications to check payroll or apply to force account work on the above contract.
COMPLETE AND SUBMIT THIS FORM WITH THE FIRST CERTIFIED PAYROLL OR WHEN THERE HAVE BEEN CHANGES.

Classification	Fringe Benefit Hourly Amount	Name and Address of Plan, Fund, or Program
Effective Date	Vacation \$ _____ Health and Welfare \$ _____	
Subsistence and/or Travel Pay	Pension \$ _____ Apprentice or Training Fees \$ _____	
\$	Other \$ _____	

Classification	Fringe Benefit Hourly Amount	Name and Address of Plan, Fund, or Program
Effective Date	Vacation \$ _____ Health and Welfare \$ _____	
Subsistence and/or Travel Pay	Pension \$ _____ Apprentice or Training Fees \$ _____	
\$	Other \$ _____	

Classification	Fringe Benefit Hourly Amount	Name and Address of Plan, Fund, or Program
Effective Date	Vacation \$ _____ Health and Welfare \$ _____	
Subsistence and/or Travel Pay	Pension \$ _____ Apprentice or Training Fees \$ _____	
\$	Other \$ _____	

I certify under penalty of perjury that fringe benefits are paid to the approved Plans, Funds, or Programs listed above.

NAME AND TITLE (Please Print)

SIGNATURE	BUSINESS	TELEPHONE
-----------	----------	-----------

ADA Notice For individuals with sensory disabilities, this document is available in alternate formats. For alternate format information, contact the Forms Management Unit at (916) 445-1233, TTY 711, or write to Records and Forms Management, 1120 N Street, MS-89, Sacramento, CA 95814.

LOCAL HIRING RESIDENCY COMPLIANCE DOCUMENTATION

In conformance with Article IV in Chapter 12 of the Salinas Municipal Code, each Contractor and Subcontractor shall complete and attach this **Local Hiring Residency Compliance Documentation** to each weekly prevailing wage statement as they are submitted to the City Engineer.

Project Title: _____ **Project No.:** _____

For The Pay Period Ending: _____

Contractor (or Subcontractor): _____ **License No.:** _____

Address: _____ **City:** _____ **State:** _____ **Zip:** _____

1. For each employee, complete residency compliance information by checking appropriate trade:

Employee Name:	Classification/Trade:	** Resident of Monterey Bay Area:
1.	Journeyman __ Apprentice __ Other __ Trade:	Yes No
2.	Journeyman __ Apprentice __ Other __ Trade:	Yes No
3.	Journeyman __ Apprentice __ Other __ Trade:	Yes No
4.	Journeyman __ Apprentice __ Other __ Trade:	Yes No
5.	Journeyman __ Apprentice __ Other __ Trade:	Yes No
6.	Journeyman __ Apprentice __ Other __ Trade:	Yes No
7.	Journeyman __ Apprentice __ Other __ Trade:	Yes No

**Resident of Monterey Bay Area = Living in Monterey, Santa Cruz, San Benito Counties or hired through a local hiring hall with jurisdiction over the Monterey Bay Area.

2. Calculate total weekly project local hiring percentage based on all labor work hours reported on prevailing wage statement: %

3. I certify that the **information contained in this form is true and correct, to the best of my knowledge.** (Please sign all pages.) *(Submitted under penalty of perjury, Salinas City Code, Section 12-31.)*

Signature

Date

Name (Please Print)

Title or Position (Please Print)

Page ____ of ____

PUBLIC WORKS DEPARTMENT BID PROTEST

City Of Salinas

Bidder's attention is directed to the, "CITY OF SALINAS SPECIAL PROVISIONS SECTION 2 PROPOSAL REQUIREMENTS AND CONDITIONS", Subsection 2-1.04.

Today's Date: _____

Project Title: _____ Bid Opening Date: _____

Contractor: _____

Contact Name: _____ Phone: _____

Address: _____

City: _____ State: _____ Zip: _____

Chapter 12-39. - Bid protests of the City Code provides: Any Contractor who has submitted a Bid but is not the apparent lowest responsible Bidder on a City Contract may file a protest. The Bid protest shall be filed with the City Clerk within **three working days** of the Bid opening. The City Council shall hear the Bid protest prior to adopting a resolution authorizing the Bid award and execution of the Contract. In cases where the Contract is not executed by the City pursuant to City Council resolution, the Bid protest shall be heard by the City Council prior to the time the City issues a Notice to Proceed or the appropriate City official executes the contract on behalf of the City. The protesting party may protest the Bid award for the City's or successful Bidder's failure to comply with the requirements of this article, the Bid documents, or any other applicable provision of this Code. The City Council shall sustain a Bid protest only if it finds evidence that award of the Bid would violate the Code or other applicable law. The decision of the Council shall be final.

The Contractor listed above wishes to protest one or more of the bid processes used to make the determination of the lowest responsible Bidder. The following is a statement that describes the circumstances and the issues under protest. (Additional sheet(s) can be attached as needed.)

Please be as specific as possible:

The following is a statement that clearly describes the remedy being recommended by the above Contractor. (Additional sheets can be attached as needed.)

Please be as specific as possible:

I certify under penalty of perjury that the information contained in this form is true and correct, to the best of my knowledge. (Please include this statement on all pages with an authorized signature.)

Signature in blue ink

Name (Please Print)

Title or Position (Please Print)

Date

Number of Pages (including those attached) _____

CITY OF SALINAS NOTICE OF POTENTIAL CLAIM

FOR CITY USE ONLY

Received by _____ Date _____
(For Resident Engineer)

DC-CEM-6201 (REV 7/00)

TO _____ CONTRACT NUMBER _____ DATE _____
(Resident Engineer)

The particular circumstances of this potential claim are described in detail as follows:

The reasons for which I believe additional compensation may be due:

The nature of the costs involved and the amount of the potential claim are described as follows:
(If accurate cost figures are not available, provide an estimate, or describe the types of expenses involved)

The undersigned originator (Contractor or Subcontractor as appropriate) certifies that the above statements are made in full cognizance of the California False Claims Act, Government Code sections 12650-12655. The undersigned further understands and agrees that this potential claim is to be further considered unless resolved, shall be restated as a claim in response to the States proposed final estimate in accordance with Section 9-1.07B of the Standard Specifications.

SUBCONTRACTOR or CONTRACTOR
(Circle One)

(Authorized Representative)

For Subcontractor notice of potential claim

This notice of potential claim is acknowledged and forwarded by

PRIME CONTRACTOR

(Authorized Representative)

CEM-6201 (REV. 7/00)



CITY OF SALINAS - PUBLIC WORKS DEPARTMENT

SUBCONTRACTOR SUBMITTAL FORM

ALL FIRST TIERED SUBCONTRACTORS PERFORMING WORK ON SITE MUST BE LISTED ON THIS FORM AND SUBMITTED TO THE CITY FOR APPROVAL
(THIS FORM DOES NOT APPLY TO THE SUBSTITUTION OF A LISTED SUBCONTRACTOR.)

PRIME CONTRACTOR NAME		CIP #				
BUSINESS ADDRESS						
CITY AND STATE		ZIP CODE				
SUBCONTRACTORS (Name, Business Address, Phone)	DIR # EXP. DATE	CONTRACTOR LICENSE # EXP. DATE	CITY BUSINESS *LICENSE #	ITEM OF WORK (List All Bid Items # to be performed or Particular Scope of Work)**	SUBCONTRACT AMOUNT	% OF TOTAL CONTRACT
TOTALS						

Only approved sub-contractors can perform work at Job Site. Unlisted sub-contractors will be removed from job site. Contractors are subject to the California Subletting and Subcontracting Fair Practices Act including penalties set forth in Section 4110 and 4111.

* Business license shall be acquired before commencement of work.

** Indicate % of Bid Item or Scope of Work if multiple subcontractors are involved with the same Bid Item.

CONTRACTOR'S SIGNATURE	DATE
APPROVED BY:	
CITY PROJECT MANAGER SIGNATURE	DATE

cc: Project file, Admin. Supervisor, Labor Compliance Officer, Inspector

**PART D –
SPECIAL PROVISIONS**

**CITY OF SALINAS
PUBLIC WORKS DEPARTMENT**

**LANDSCAPE SERVICES FOR
MONTE BELLA MAINTENANCE DISTRICT**

SECTION 1 SPECIFICATIONS

All work to be done under this Contract shall conform to the applicable requirements of the STANDARD SPECIFICATIONS DESIGN STANDARDS AND STANDARD PLANS, 2008 Edition, City of Salinas, Public Works Department, herein referred to as the "Standard Specifications". The State Standard Specifications and Standard Plans, May 2006 Editions, herein referred to respectively as "State Standard Specifications" and "State Standard Plans", shall be used.

In the event of conflict between the Specifications and these Special Provisions, the latter shall take precedence over and be used in lieu of such conflicting portions. The listing of certain salient sections from the Standard Specifications and these Special Provisions shall not in any way relieve the Contractor of complying with each and every section of the Standard Specifications.

Wherever in the Special Provisions, Notice to Bidders, Proposal, Contract, or other Contract documents the following terms are used; the intent and meaning shall be interpreted as follows:

State - City of Salinas

Department of Transportation - City of Salinas

Director - City of Salinas

Division of Highways - City of Salinas

Engineer - City Engineer

Local Public Agency - City of Salinas

Owner - City of Salinas

SECTION 2 PROPOSAL REQUIREMENTS AND CONDITIONS

2-1.01 GENERAL

The Bidder shall examine carefully the site of work contemplated, the specifications, and the proposal and contract forms therefor. The submission of a bid shall be conclusive evidence that the bidder has investigated and is satisfied as the conditions to be encountered, as to the character, quality, and scope of work to be performed, the qualities of materials to be furnished, and as to the requirements of the proposal, plans, specifications, and the contract.

The Specifications are general information only and are for outlining the limits of work and showing the general layout of the existing landscape. It shall be the Contractor's responsibility to verify the amounts of trees, lawn, shrubs, and other items/areas to be maintained. Discrepancies between the plans and items in the field shall be brought to the attention of the Engineer. Additional payment for said discrepancies shall not be allowed.

The Bidder's attention is directed to the provisions in Section 2, "Proposal Requirements and Conditions," of the Standard Specifications and these Special Provisions for the requirements and conditions which he must observe in the preparations of the proposal form and the submission of the bid.

Deficiency Notice:

The Contractor is required to correct deficiencies within the time specified by the City of Salinas. If the deficiency is not corrected within the time specified by the City, City labor will be called out to complete the work. Such work shall be done on a force account basis with an additional call out charge of \$75.00 per hour for each call-out. Call-out of City forces during off-hours, resulting from improper programming of sprinkler controllers, will be charged to the Contractor at time and a half. It also should be noted that there is a minimum three-hour charge for labor on any call-out.

2-1.02 EXAMINATION OF SPECIFICATIONS, CONTRACT AND SITE OF WORK

The Bidder shall examine carefully the site of work contemplated, the Plans and Specifications, and the Proposal and Contract Forms therefore. The submission of a Bid shall be conclusive evidence that the Bidder has investigated and is satisfied as to the conditions to be encountered, as to the character, quality, and scope of work to be performed, the quantities of materials to be furnished, and as to the requirements of the Proposal, Plans, Specifications, and the Contract.

All questions about the meaning or intent of the Contract Documents shall be submitted to the City of Salinas through the project page on the Planet Bids website. Replies will be issued by Addenda electronically on-line through the PlanetBids Vendor Portal website and ONLY to Bidders who are registered Prospective Bidders for this project. **Questions received less than 10 calendar days prior to the date of the opening of bids will not be answered.** Only questions answered by Addenda will be binding. Oral and other interpretations or clarifications will be without legal effect.

Bidder is cautioned to make such independent investigation and examination as he/she deems necessary to satisfy himself/herself as to conditions to be encountered in the performance of the work and with respect to possible local material sources, the quality, and quantity of material available from such property, and the type and extent of processing that may be required in order to produce material conforming to the requirements of these Special Provisions.

The availability or use of information described within the Provisions in Section 2-1.01 is not to be construed in any way as a waiver of the Provisions of the first paragraph of the State Standard Specification in Section 2-1.01 of these Special Provisions, and the Bidder is cautioned to make such independent investigation and examination as he/she deems necessary to satisfy himself/herself as to conditions to be encountered in the performance of the work and with respect to possible local material sources, the quality, and quantity of material available from such property and the type and extent of processing that may be required in order to produce material conforming to the requirements of these Special Provisions.

No information derived from inspection of records of investigation or compilation thereof made by the City of Salinas or from the City Engineer, or his/her assistants, shall in any way relieve the Bidder or Contractor from any risk or from properly fulfilling the terms of the Contract.

2-1.03 UNSCHEDULED / EXTRA WORK RATES

Contractor is to furnish the City of Salinas, hourly rates for unscheduled landscape maintenance work, in accordance with the following specifications and provisions.

All unscheduled work shall have prior authorization of the City. Unscheduled work is requested on an as-needed basis and the Contractor is not guaranteed all such work in areas where Contractor is currently providing landscape services to the City. The amount of time each unscheduled job may take is subject to negotiation with the City. Rates offered below would be a major determinant in whether unscheduled work will be furnished by the Contractor providing contract services in the same area.

Should unscheduled work not be provided by the Contractor, said Contractor may be required to coordinate with the City and another Contractor of the City's choosing in order to complete unscheduled repairs.

The Inspector may authorize the Contractor to perform additional work, including but not limited to, repairs and replacements when the need for such work arises. Should such repairs or replacements be necessary as a result of Contractor's negligence, Contractor will be responsible for completing such repairs or replacing damaged property at no additional cost to the City.

- A. Contractor may not change the regular maintenance schedule or work force to perform unscheduled/extra work unless authorized by the Inspector.
- B. In order to be considered for extra work projects both in and outside of their contracted site, the Contractor must maintain their landscape maintenance site in a manner that meets or exceeds City Standards for landscape maintenance. In all cases, the Inspector will determine standards.
- C. Prior to performing any additional work, the Contractor shall give a verbal or written estimate of labor and materials to the Inspector. No work shall commence without a verbal or written estimate. Within 48 hours of verbal or written authorization from Inspector, Contractor shall submit a written estimate. Should a lane closure be required for unscheduled work, cost of permit and equipment shall be detailed in the estimate.
- D. Notwithstanding the above authorization, when a condition exists wherein there is imminent danger of injury to the public or damage to property, the Inspector may verbally authorize the work to be performed upon receiving a verbal estimate from the Contractor. No percentage mark-up shall be added to equipment rental fees.
- E. All additional work shall commence on the specified date established and Contractor shall proceed diligently to complete said work within the time allotted. All replacements of plant material or irrigation components shall be the same like and kind as what is missing or needed to be replaced, unless authorized by the Inspector. Contractor is required to submit highlighted copies of receipts for materials purchased. Receipts shall be turned in with contractor's invoice for said repair and replacements.
- F. Inspector shall authorize verbally or in writing, any unscheduled work prior to work being done. Contractor will submit a written quote, detailing materials and labor charges used for extra work. The Inspector will generate a work order, which authorizes the contractor to submit an invoice for work performed.

2-1.04 BID PROTEST FEE

Bid protests are limited to "Bidders" as defined in the Contract Documents. Any Bid protest must be submitted in writing to the City Clerk before 5:00 p.m. (as determined by the clock in the City Clerk's Office) within 3 working days after Bid opening.

(a) Any protest of the proposed award of Bid to the Bidder deemed the lowest responsible Bidder must be submitted in writing to the City no later than 5:00 p.m. within 3 working days following the date of the Bid opening. If a Bidder protests more than one Bid, the Bidder shall file a separate protest as to each Bid being protested, complying with this section.

(b) The initial protest document must contain a complete statement of the basis for the protest. The protest must refer to the specific portion of the document or the specific statute that forms the basis for the protest. The protest must include the name, address, and telephone number of the person representing the protesting party. The protest must be signed and submitted under penalty of perjury.

(c) The party filing the protest must concurrently transmit a copy of the initial protest document and any attached documentation to the Bidder whose Bid is being protested, as well as to all other parties with a direct financial interest that may be adversely affected by the outcome of the protest. Such parties shall include all other Bidders who appear to have a reasonable prospect of receiving an award depending upon the outcome of the protest. Faxed or emailed copies are acceptable, with confirmation of receipt by the Bidder or person to whom it was sent.

(d) The protestor must have actually submitted a Bid on the project or have been specifically excluded from submitting a Bid due to an action by the City. A Subcontractor of a party submitting a Bid on this project may not submit a Bid protest. A party may not rely on the Bid protest submitted by another Bidder, but must timely pursue its own protest.

(e) The City Council shall hear the Bid protest prior to adopting a resolution authorizing the Bid award and execution of the contract. In cases where the contract is not executed by the City pursuant to City Council Resolution, the Bid protest shall be heard by the City Council prior to the time the City issues a Notice to Proceed or the appropriate City official executes the contract on behalf of the City. The decision of the Council shall be final.

(f) The protestor shall also submit a non-refundable fee of **\$1,000.00** per protest via certified check made payable to the City of Salinas to reimburse its costs in reviewing and investigating the Bid protest. Any protest submitted without the fee shall be returned without further action by the City.

(g) Any protest not complying with this section shall be returned without further action by the City.

(h) The procedure and time limits set forth in this paragraph are mandatory, are Bidder's sole, and exclusive remedy in the event of Bid protest. Bidder's failure to comply with these procedures shall constitute a waiver of any right to further pursue the Bid protest, including filing a Government Code Claim or any legal proceedings.

SECTION 3 AWARD AND EXECUTION OF CONTRACT

The Contractor's attention is directed to the Provisions in Section 3, "Award and Execution of Contract", of the Standard Specifications and Section 2 the "Proposal Requirements and Conditions", of these Special Provisions for the requirements and conditions concerning award and execution of the Contract.

Certificates of Insurance shall be furnished by the Contractor and shall be returned with the signed Contract and Contract bonds within 15 calendar days after receipt. The Notice to Proceed with the work **shall not** be issued by the City Engineer until all such documents are submitted.

The Contractor shall have 15 calendar days immediately following award of Contract (not Notice to Proceed) to furnish materials submittals.

In determining the lowest "responsible" Bidder, consideration shall be given to the general competency of Contractor in regard to the work covered by the Proposal. To this end, each Proposal shall be supported by the "Bidder's Statement of Financial Responsibility, Technical Ability, and Experience" on the form(s) found herein. Failure of the Bidder to provide requested information in a complete and accurate manner shall be considered non-responsive resulting in rejection of the Bid. Additionally, the City of Salinas reserves the right to disqualify or refuse to consider a Proposal if a Bidder is in default for any of the following reasons:

- a) Lack of competency and adequate machinery, plant and other equipment, as revealed by the documents requested
- b) Uncompleted work, which in the judgment of the City Engineer, might hinder or prevent the prompt completion of additional work if awarded
- c) Failure to comply with any regulation of the City of Salinas
- d) Default under previous Contracts.

If awarded, this Contract shall be awarded to the responsible Bidder submitting the lowest Bid who meets the financial and technical requirements. The City of Salinas reserves the right to withhold award of Bid for 90 calendar days from the Bid opening date.

SECTION 4 BEGINNING OF WORK, TIME OF COMPLETION, LIQUIDATED DAMAGES AND TEMPORARY SUSPENSION OF WORK

The Contractor's attention is directed to the provisions of Section 8, "Prosecution and Progress," of the Standard Specifications and the following provisions:

The Contractor shall begin the work during the first week of, and shall perform the work outlined in these special provisions for the maintenance of the area described for a period of three years (36 months) from said date. This contract may be renewed for two (2) year, provided the Contractor requested, in writing, three (3) months before the expiration date and with the approval of the Director of Public Works.

SECTION 5 GENERAL

SECTION 5-1 MISCELLANEOUS

5-1.01 LABOR NONDISCRIMINATION

Attention is directed to the following Notice that is required by Chapter 5 of Division 4 of Title 2, California Code of Regulations and the City's Federal Mandated Disadvantage Business Enterprise ("DBE") Program.

NOTICE OF REQUIREMENT FOR NONDISCRIMINATION PROGRAM (GOV. CODE, SECTION 12990)

Your attention is called to the "Nondiscrimination Clause", set forth in the Provisions in Section 7 1.01A(4), "Labor Nondiscrimination", of the Standard Specifications, which is applicable to all nonexempt State Contracts and Subcontracts, and to the "Standard California Nondiscrimination Construction Contract Specifications" set forth therein. The Specifications are applicable to all nonexempt state construction Contracts and Subcontracts of **\$5,000.00 or more**.

Furthermore, the prime Contractor or Subcontractor shall not discriminate on the basis of race, color, national origin, or sex in the performance of this Contract. Failure by the Contractor to carry out these requirements is a material breach of this Contract, which may result in the termination of this Contract or such other remedy, as recipient (i.e., the City of Salinas) deems appropriate.

5-1.02 WAGE DETERMINATION

All wage scales shall be in accordance with applicable determinations made by the Director of the Department of Industrial Relations ("DIR") of the State of California, as provided by Article 2, Chapter 1, Division 2, Part 7 of the Labor Code of the State of California, commencing with Section 1771. In accordance with Section 1773.2 of the said Labor Code, copies of the aforesaid determinations of the Director of the DIR are available on the website address <http://www.dir.ca.gov/OPRL/DPreWageDetermination.htm> They shall apply to the Construction Contract and all Subcontractors thereunder.

The wage rates determined by the Director of DIR and published in the Department of Transportation publication entitled General Prevailing Wage Rates refer to expiration dates. If the published wage rate does not refer to a predetermined wage rate to be paid after the expiration date, said published rate of wage shall be in effect for the life of this Contract. If the published wage rate refers to a predetermined wage rate to become effective upon expiration of the published wage rate and the predetermined wage rate is on file with the DIR, such predetermined wage rate shall become effective on the date following the expiration date and shall apply to this Contract in the same manner as if it had been published in said publication. If the predetermined wage rate refers to one or more additional expiration dates with additional predetermined wage rates, which expiration dates occur during the life of this Contract, each successive predetermined wage rate shall apply to this Contract on the date following the expiration date of the previous wage rate. If the last of such predetermined wage rates expires during the life of this Contract, such wage rate shall apply to the balance of the Contract.

The "Statement of Compliance" and "Payroll Report" shall be on forms furnished by the City. Reduced copies of the "Statement of Compliance" and "Payroll Report" forms are attached in Part "C" of these Specifications. **No other forms shall be accepted.**

Additionally, all contractors and subcontractors must furnish certified payroll records directly to the Labor Commissioner (aka Division of Labor Standards Enforcement) on a weekly basis and in the format prescribed by the DIR, which may include electronic submission.

5-1.03 ENFORCEMENT OF THE CITY'S LOCAL HIRING ORDINANCE REQUIREMENTS

During the term of the contract, the Contractor and all subcontractor(s) shall submit a completed and signed “Local Hiring Residency Compliance Documentation” form with each weekly prevailing wage statement as required in the plans and specifications of the project. This form will be reviewed by the Residence Inspector for the City and to be compared to the list of employees to assure compliance. If for any reason the contractor needs to hire additional employees or subcontractors, the Residence Inspector will require an additional “Statement of Good Faith for Local Hire” form be prepared, signed, and submitted along with the weekly report.

5-1.04 DIR REGISTRATION

A contractor or subcontractor shall not be qualified to bid on, be listed in a bid proposal, subject to the requirements of Section 4104 of the Public Contract Code, or engage in the performance of any contract for public work, as defined in this chapter, unless currently registered and qualified to perform public work pursuant to Section 1725.5. It is not a violation of this section for an unregistered contractor to submit a bid that is authorized by Section 7029.1 of the Business and Professions Code or by Section 10164 or of the Public Contract Code, provided the contractor is registered to perform public work pursuant to Section 1725.5 at the time the contract is awarded.

All Contractors (prime and subs) must possess and maintain such registration with DIR in order to be awarded and to perform work on public works projects. The following is the link to DIR’s Contractor Registration searchable database: <https://efiling.dir.ca.gov/PWCR/Search.action>.

5-1.05 SUBCONTRACTING

Per section 5-1.13 of the 2015 Caltrans Standard Specifications, Prime contractor shall perform work equaling at least 30 percent of the value of the original total bid with your employees and with equipment you own or rent, with or without operators.

SECTION 5-2 QUALITY ASSURANCE

A. Qualifications:

1. Experience: The landscape contractor or maintenance subcontractor shall have a full-time employee assigned to the job as foreman for the duration of the contract. He/she shall have a minimum of four (4) years experience in landscape maintenance supervision, with experience or training in turf management, entomology, pest control, soils, fertilizers and plant identification. All tree related work shall be supervised by a Qualified Applicator Certificate holder. All pesticide recommendations shall be made by a Pest Control Advisor.
2. Labor Force: The landscape maintenance labor force shall be thoroughly familiar with, and trained in the work to be accomplished and shall perform the task in a competent, efficient manner acceptable to the City.

The Contractor must have a full-time employee who can competently work on irrigation systems, including the testing, rebuilding and/or replacement of valves, controllers and main irrigation line breaks.

It is the Contractor's responsibility, without further direction from the Inspector (except as specified herein), to assure all work is being done per specifications. Contractor shall inspect every site once per day at a minimum, regardless of minimum requirements stated on the Maintenance Performance Schedule.

3. The Contractor will be required to have a twenty-four (24) hour emergency phone number where he/she can be reached with no more than fifteen (15) minute delay in call back time. Once notified, contractor shall respond to an emergency within thirty (30) minutes. Contractor is further required to have an active email address, to receive any correspondence from the Inspector.
4. Contractor shall not work or perform any operations, particularly during periods of inclement weather, which may destroy or damage ground cover, athletic/turf areas, trees or shrubs. Any debris or litter which collects as a result of inclement weather or flooding, shall be removed during the next scheduled service day.
5. Contractor must have office within the City of Salinas.
6. Contractor must provide the following organizational information:
 - a) Organization Chart inclusive of executives and descending to on-site crew leader.
 - b) Brief description of company personnel and training procedures.
 - c) The Contractor shall provide a qualified, English speaking/writing crew leader or supervisor to oversee workforce.
A listing of guaranteed size of work force by job classification shall be provided to the City prior to beginning work.
7. PROJECT/SITE CONDITIONS- At the beginning of the maintenance period, the City's designated representative and the Contractor shall visit the site and walk it to clarify the scope of work and understand existing project and site conditions. Documentation of the general conditions of all plant materials shall be made to determine which are healthy, damaged, dead or dying. Documentation of the general condition of the irrigation system shall be completed to make sure that faulty electrical valves, controllers and broken or inoperable sprinkler heads are reported.

B. Personal Attire and Equipment

1. The Contractor shall require each of his employees to adhere to basic Public Works standards of working attire. This includes uniforms, proper shoes and other gear required by State Safety Regulations, and proper wearing of the clothing. Shirts shall be worn at all times, buttoned and tucked in. Blue or red colored uniforms are not acceptable.
2. Contractor shall display the name of his firm on any vehicles used by the Contractor's employees to carry supplies and equipment. The firm name shall be in letters large enough to be easily legible from a distance of one-hundred (100) feet. All contractor trucks and other vehicles shall be uniform in color scheme and paint. All vehicles and equipment shall be in good condition and appearance. All vehicles will display a sign on the vehicle while working on City areas indicating the contractor is under contract with the City. This sign shall be visible at all times.

3. Contractor shall be aware of and shall comply with all City ordinances governing landscape maintenance work as applicable to individual locations being maintained.
4. It shall be the Contractor's responsibility to supply all safety equipment and to educate their employees in the rules of safety. Safety vests are to be worn at all times while working on City property.
5. Requirements
 - a) Supervision: The foreman shall directly supervise the work force at all times. Notify City of all changes in supervision.
 - b) Identification: Provide proper identification at all times for landscape maintenance firm's vehicles and labor force.

C. Public Convenience and Safety

1. Contractor acknowledges and agrees that public safety is of utmost importance, and Contractor agrees that during the progress of the Work, Contractor shall constantly protect and preserve the safety of the public.
2. Contractor shall not unnecessarily cause inconvenience to the public during the progress of the Work and shall minimize the inconvenience caused by Contractor's operations. Such operations include, but are not limited to, work performed on or adjacent to the Work site, traffic lane and pedestrian closures and deliveries of material and equipment.
3. If a scheduled service day falls on a Federal, State or City holiday, Contractor must provide scheduled service within two days before or after the holiday.
4. Where public safety is affected, the Contractor shall make immediate equipment repairs or removals of landscape and irrigation material and shall report such repairs or removals within 24- hours to the Maintenance Operations Manager or designee
5. Safety provisions shall conform to Cal-OSHA Safety Orders, and all other applicable federal, state, county, and local laws, ordinances, codes, and regulations in performing the work under this Contract. Where any of these are in conflict, the more stringent requirement shall be followed. The Contractor's failure to thoroughly familiarize itself with the aforementioned safety provisions shall not relieve it from compliance with the obligations and penalties set forth therein. The Contractor shall develop and maintain for the duration of the Contract, a safety program that will effectively incorporate and implement all required safety provisions. The Contractor shall appoint an employee who is qualified and authorized to supervise and enforce compliance with the safety program
6. Signage – The Contractor shall furnish and install all safety street signs, cones, and other facilities, which are necessary to expedite the passage of public traffic through or around the work. This is to prevent accidents, damage, or injury to the public, and to give adequate warning to vehicle or pedestrian traffic or to the public of any dangerous conditions to be encountered.
7. Sound Control Requirements - The Contractor shall comply with all local sound control and noise level rules, regulations and ordinances which apply to any work performed pursuant to the Contract.

Each internal combustion engine, used for any purpose on the job or related to the job, shall be equipped with a muffler of a type recommended by the manufacturer. No internal combustion engine shall be operated on the project without said muffler.

SECTION 5-3 PAYMENT

PROMPT PROGRESS PAYMENT TO SUBCONTRACTORS

A prime Contractor or Subcontractor shall pay any Subcontractor not later than 7 calendar days of receipt of each progress payment in accordance with the Provision in Section 7108.5 of the California Business and Professions Code concerning prompt payment to Subcontractors. The 7 calendar days are applicable unless a longer period is agreed to in writing between the Contractor and the City Engineer. Any delay or postponement of payment over 30 calendar days may take place only for good cause and with the City Engineer prior written approval. Any violation of Section 7108.5 shall subject the violating Contractor or Subcontractor to the penalties, sanction, and other remedies of that Section. Federal law (49CFR26.29) require than any delay or postponement of payment over 30 calendar day of receipt of each payment may take place only for good cause and with the agency's prior written approval. These requirements shall not be construed to limit or impair any contractual, administrative, or judicial remedies otherwise available to the prime Contractor or Subcontractor in the event of a dispute involving late payment or nonpayment by the prime Contractor, deficient subcontract performance, or noncompliance by a Subcontractor. This Provision applies to both Contractors and Subcontractors.

PROMPT PAYMENT OF FUNDS WITHHELD TO SUBCONTRACTORS

The prime Contractor, or Subcontractor, shall return all monies withheld in retention from a Subcontractor within 30 calendar days after receiving payment for work satisfactorily completed and accepted including incremental acceptances of portions of the Contract work by the City of Salinas. Federal law (49CFR26.29) requires that any delay or postponement of payment over 30 calendar days may take place only for good cause and with the City Engineer prior written approval. Any violation of this provision shall subject the violating prime Contractor or Subcontractor to the penalties, sanctions, and other remedies specified in Section 7108.5 of the Business and Professions Code. These requirements shall not be construed to limit or impair any contractual, administrative, or judicial remedies otherwise available to the prime Contractor or Subcontractor in the event of a dispute involving late payment or nonpayment by the prime Contractor, deficient subcontract performance, or noncompliance by a Subcontractor. This Provision applies to both Contractors and Subcontractors.

SECTION 5-4 RESPONSIBILITIES AND MAINTAINING TRAFFIC

The Contractor's attention is directed to the Provisions in Section 7-1.01G, "Water Pollution", of the Standard Specifications

The Contractor shall comply with the requirements of CAL-OSHA, the applicable provisions of local, state, and federal regulations governing the project work.

For Traffic Maintenance, the Contractor's attention is directed to Section 7-1.08, "Public Convenience" and 7-1.09, "Flagging Costs", of the Standard Specifications and these Special Provisions. Nothing in these Special Provisions shall be construed as relieving the Contractor from his/her responsibility as provided in said Section 7-1.09. Contractor shall provide delineators for traffic safety:

- A. Whenever immediate action is required to prevent impending injury, death, or property damage, and precautions which are the Contractor's responsibility have not been taken and are not expected to be taken, the City may, after reasonable attempts to notify the Contractor, cause such precautions to be taken and shall charge the cost thereof against the Contractor, or may deduct such cost from any amount due or becoming due from the City. City action or inaction under such circumstances shall not be construed as relieving the Contractor of his/her surety from liability.
- B. The Contractor shall notify the Police, Fire, Traffic, Monterey-Salinas Transit, Engineering Department of jurisdictional agencies involved, affected property owners and businesses, and news media (radio, TV, newspaper) at least **48 hours** in advance of any work that will delay traffic. The Contractor shall cooperate with local authorities relative to handling traffic through the area and shall make his/her own arrangements relative to keeping the working area clear of parked vehicles.

The Contractor shall also be responsible for compliance with additional public safety requirements which may arise during construction. He/she shall exercise special caution against dangerous conditions, and shall provide, install, and maintain temporary barricades and fencing as may be necessary to protect the public. All construction traffic control devices shall be in place and operational prior to beginning work or different phases throughout the contract. Within the area of work barricades, signs, lights, flashers, and other safety devices shall be used by the Contractor to direct vehicular and pedestrian traffic. During any day between 9:00 a.m. and 3:30 p.m., the Contractor may limit traffic to one lane in each direction with approved traffic control measures, unless otherwise directed by the City Engineer.

Within the area of work barricades, signs, lights, flashers and other safety devices shall be used by the Contractor to direct vehicular and pedestrian traffic. Unless otherwise directed by the City Engineer, the Contractor shall maintain pedestrian and two-way vehicular traffic on the streets at all times. **Closing of any streets will not be allowed.** Traffic safety devices shall be in good repair at all times. Traffic safety devices in need of repair or paint shall be removed immediately from the project on order of the Project Inspector. Upon completion of work, the Contractor shall promptly remove all signs and warning devices.

- C. The Contractor's special attention is directed to Section 10 of the Standard Specifications regarding dust control requirements. The Contractor shall abate dust nuisance by cleaning, sweeping, and sprinkling with water or other means as necessary during all phases of construction including weekends, holidays, and any other times as necessary. No mud or cement slurry resulting from saw cutting is to be washed into catch basins. Cleanup expenses to the City at job site due to the Contractor's failure to comply with the Provisions in the Standard Specifications and these Special Provisions will be charged to the Contractor. The use of water which may result in mud on public streets will not be permitted as substitute for sweeping or other materials. Payment for dust control shall be considered as included in the various pay items and no additional compensation shall be allowed therefore.

Personal vehicles of the Contractor's employees shall not be parked on the traveled way or shoulders, including any section closed to public traffic.

Whenever vehicles or equipment are parked within six feet of a traffic lane, the shoulder area shall be closed with florescent traffic cones or portable delineators placed on a taper in advance of the parked

vehicles or equipment and along the roadway at 25-foot intervals to a point not less than 25 feet past the last vehicles or piece of equipment. A minimum of 9 cones or portable delineators shall be used for the taper. A C23 (Road Work Ahead) or C24 (Shoulder Work Ahead) sign shall be mounted on a telescoping flag tree with flags. The flag tree shall be placed where as directed by the City Engineer.

All traffic cones used on the project shall conform to the requirements for fluorescent traffic cones in said Section 7-1.092. The top of fluorescent traffic cones used in the work during the hours of darkness as defined in Division 1, Section 280, of the California Vehicle Code, shall be covered by a 7-inch flexible vinyl reflective cone sleeve. The Provisions in Section 7-1.095, "Flagging Costs", of the Standard Specifications are amended to provide that the entire cost of furnishing all flagmen will be borne by the Contractor.

Where work is to be performed on private properties (removal and construction of walks, driveway, etc.), the City Engineer will obtain written permission for right-of-entry from the respective owner prior to performing the work. No work shall be commenced by the Contractor until such permission has been granted and until notified by the City Engineer. The Contractor shall be responsible for any and all property damage and public liability resulting from his/her operation on said private properties.

D. Unless otherwise directed by the City Engineer, the Contractor shall at all times maintain vehicular and pedestrian access to all properties fronting City streets. The Resident City Engineer shall determine if temporary driveways will be necessary within the limits of work during construction. Traffic shall be maintained on one-half of the street at all times. The Contractor's special attention is directed to Section 10 of the Standard Specifications regarding dust control requirements. The Contractor shall abate dust nuisance by cleaning, sweeping, and sprinkling with water or other means as necessary during all phases of construction including weekends, holidays, and any other times as necessary. Cleanup expenses to the City at various job sites due to the Contractor's failure to comply with the Provisions in the Standard Specifications and these Special Provisions will be charged to the Contractor. The use of water which may result in mud on public streets will not be permitted as substitute for sweeping or other materials. Payment for dust control shall be considered as included in the various pay items and no additional compensation shall be allowed therefore.

E. The Contractor shall provide necessary safeguards and shall exercise caution against injury or defacement of any existing site improvements and plantings. The Contractor shall be responsible for any damage resulting from his/her operations and shall repair or replace such damage at his/her own expense. No trucks or vehicles of any kind shall be allowed to pass over area unless adequate protection is provided. Unless designated otherwise, all existing improvements shall be repaired or replaced, in kind, at the Contractor's expense.

Temporary ramps, backfill, or covers for incomplete trenching/backfill operations shall also be furnished by the Contractor at the end of each day's work for the protection of vehicular and pedestrian traffic.

The Contractor shall be responsible for any damage to the work which occurs before final acceptance. He/she is to securely cover all openings into the systems and protect all apparatus, equipment, or appliance, both before and after being set in place, to prevent obstructions in the pipes and breakage, misuse, or disfigurement of the apparatus, equipment, or appliance. Contractor shall be responsible for damage to all existing utilities, whether or not they are indicated on the drawings.

F. Contractor shall provide delineators for traffic safety until such time as all cat tracking has been

performed. Cat tracking shall be completed within 8 hours of completed paving/resurfacing at the respective location and shall be maintained in a legible and traffic safety manner by the Contractor until final striping or pavement markings are in place.

SECTION 6 BLANK

SECTION 7 MATERIALS

7-1.01 MISCELLANEOUS

7-1.02 GENERAL

Attention is directed to the Provisions in Section 6, "Control of Materials", of the State Standard Specifications and these Special Provisions.

All materials required to complete the work under this Contract shall be furnished by the Contractor except when otherwise specified herein. The City shall have the right to inspect any material specified herein. The items ordered must be designed to comply with all federal, state, and local safety regulations and/or ordinances. Equipment supplies or services that fail to comply with the specifications herein as regards to design, material or workmanship are subject to rejection at the option of the City. Materials rejected shall be immediately removed from the premises at the Contractor's/vendor's expense.

SECTION 8 BLANK

SECTION 9 DESCRIPTION OF PROJECT

The project shall involve the furnishing of all labor, material, equipment, and incidentals to perform the Landscape Maintenance in the Monte Bella District in accordance with the Plans and these Special Provisions. The maintenance districts are as shown on the location map and described as follows:

SECTION 9-1 SITE DESCRIPTION

MONTE BELLA MAINTENANCE DISTRICT

- 1. Both sides of Monte Bella Boulevard**-between Sconberg Parkway and Williams Road; both sides of Tuscany Boulevard, both sides of Padova Drive, both sides of Penne Way, both sides of Palermo Drive.
- 2. The Southeast side of Williams Road**-from Freedom Parkway to approximately 560 feet southwest of Monte Bella Boulevard.
- 3. The Southwest side of Freedom Parkway**-from Williams Road to Sconberg Parkway.
- 4. The Northwest side of Sconberg Parkway**-between Freedom Parkway and Bardin Road.
- 5. The center island on Freedom Parkway**-between Williams Road and Tuscany Boulevard.
- 6. Monte Bella Bioretention Area at Curb Bulb Outs.** Location list provided. 56 spots total including future locations.
- 7. Monte Bella Stormwater Retention Basin.** Mow, weedeat and trash clean up twice a year. June and October of each year.

SECTION 10 CONSTRUCTION DETAILS

SECTION 10-1 GENERAL

10-1.01 ORDER OF WORK

All work under this project shall be scheduled, coordinated and executed as necessary to meet the frequency of maintenance listed in the proposal within the constraints of the project. All operations shall be coordinated to eliminate any possibility of damage, or unnecessary removal, replacements and/or modifications to existing facilities or to facilities constructed under this project.

10-1.02 LEGAL

The Contractor's attention is directed to Section 7 of the State Standard Specifications.

The Contractor shall exercise special caution against dangerous conditions and provide temporary barricades and fencing as may be necessary to protect the public. During construction within the area of work, barricades, signs, lights, flashers, and other safety devices shall be used by the Contractor to direct vehicular and pedestrian traffic.

The Contractor's special attention is directed to Section 10 of the State Standard Specifications regarding dust control requirements.

The Contractor shall provide necessary safeguards and shall exercise caution against injury or defacement of any existing site improvements and plantings. The Contractor shall be responsible for any damage resulting from his/her operations and shall repair or replace such damage at his/her own expense. No trucks or vehicles of any kind shall be allowed to pass over area unless adequate protection is provided. Unless designated otherwise, all existing improvements shall be repaired or replaced, in kind, at the Contractor's expense.

The Contractor is to be responsible for any damage to the work which occurs before final acceptance. He/she is to securely cover all openings into the systems and protect all apparatus, equipment and appliances, both before and after being set in place, to prevent obstructions in the pipes and breakage, misuse or disfigurement of the apparatus, equipment or appliance.

Temporary ramps, backfill, or covers for incomplete trenching/backfill operations shall also be furnished by the Contractor at the end of each day's work for the protection of vehicular and pedestrian traffic.

Unless otherwise directed by the City Engineer, the Contractor shall at all times maintain vehicular and pedestrian access to all properties fronting on City of Salinas streets. **Two-way traffic shall be maintained at all times.**

10-1.03 INSPECTION AND CONTROL OF WORK

The Contractor's attention is directed to Section 5 of the Standard Specifications and Section 5-1.08 of the Special Provisions.

10-1.04 FINAL INSPECTION AND CLEANUP

At the completion of the work, a final inspection will be made by the City Engineer. The Contractor will be responsible for final cleanup of the project area in accordance of the Provisions with Section 4-1.02 of the State Standard Specifications.

10-1.05 WORKMANSHIP

All work performed under this Contract shall be of the highest quality of the trade and the Contractor shall employ only workers who are skilled and thoroughly familiar with the type of improvements proposed.

10-1.06 PROGRESS SCHEDULE

A progress schedule shall be prepared by the Contractor for this Contract and shall conform to the Provisions in Section 8-1.04 "Progress Schedule" of the State Standard Specifications and shall be delivered to the City Engineer at the pre-construction meeting. **No work shall begin until the Progress Schedule has been approved by the City Engineer.**

10-1.07 OBSTRUCTIONS

Attention is directed to Section 8-1.10, "Utility and Non-Highway Facilities," and Section 15, "Existing Highway Facilities", of the State Standard Specifications and these Special Provisions.

10-1.08 UTILITY DETERMINATION

The Contractor shall coordinate with the utility companies to locate and mark all utility mains and service laterals, including depth within the project area. Contractor shall make full determination of all underground utilities in order to prevent damage or disruption to the existing services during construction. The Contractor shall Dial 811 to contact the **Underground Service Alert ("U.S.A.")**, , **48 hours in advance before performing any trenching or excavation work.**

Contractor shall adhere to all U.S.A.-North rules and regulations. Contractor shall be responsible for protecting all utility facilities (MH lids, water valves, gas valves, etc.).

The Contractor is hereby notified that some utility conflicts, if any, may exist at the start of construction. The Contractor shall be prepared to schedule his/her work around these conflicts. The utility companies have been advised to work in close cooperation with the Contractor. While the Contractor shall be granted time extensions without penalty for utility delays if such delays impede his/her overall progress, no extra payment will be made for utility delays, except as provided in these Special Provisions. Such time extensions will furnish evidence that his/her overall progress is being delayed. Minor reassignment of work forces or equipment which may be in conflict with utility's work shall not be construed as delay in the Contractor's progress.

Utility company's work, if any, shall be done concurrently with this project and shall include work within the street right-of-way. The Contractor shall schedule and coordinate his/her installations with the utility companies to avoid any conflicts which may impede the overall progress of the project. All removals, installations, and relocations of conflicting underground and above ground utilities shall be executed by the respective utility companies at their expense.

The utilities shown on the Plans are for reference only and are based on utility company records. Known conflicts have been investigated and approximate cover indicated on Plans, if any. The Contractor shall prosecute the work exercising reasonable care not to damage any such facilities. **If the Contractor, while performing the work, discovers facilities not identified on the Plans, he/she shall immediately notify the utility company and the City Engineer in writing within 72 hours.**

The Contractor's attention is directed to the existence of certain underground facilities that may require special precautions to be taken by the Contractor to protect the health, safety and welfare of workers and of the public. Facilities requiring special precautions include, but are not limited to: natural gas pipelines, underground

telephone, cable TV and electric supply system conductors or cables either directly buried or in duct or conduit. The Contractor shall notify the City Engineer at least 24 hours prior to performing any work in the vicinity of such facilities.

Repair of pipes due to accidental or convenience removals (including equipment conflicts) shall be at the expense of the Contractor and no additional compensation will be allowed.

10-1.09 EXAMINATION OF SITE

Before submitting a Bid, each Bidder shall carefully examine the Plans and Specifications relating hereto. He/she shall also visit the site of the proposed work and shall fully inform himself/herself as to all the existing conditions relating to the construction and related labor so that he/she may fully understand the facilities, difficulties, restrictions attendant on the execution of the work, limitations applying to the work, and he/she shall estimate and include in his/her Bid a sum sufficient to cover the cost of all items which are required to attain the completed conditions contemplated in the project.

10-1.10 WATERING

Watering, if any, shall conform to the Provisions in Section 17, "Watering" of the Standard Specifications, except that full compensation for developing water supply shall be considered as included in the prices paid for the various Contract items of work involving the use of water and no separate payment will be made. Where applicable, City of Salinas Code Chapter 36A Water Conservation will take priority.

10-1.11 CONSTRUCTION EASEMENTS

Any work to be done on private properties or requiring access through private properties **shall not** be done until the City has acquired easements or right-of-entry from the property owner. Prior to starting such work, the Contractor shall verify with the City Engineer that such authority has been granted.

The Contractor will confine his/her operations within the limitations of construction easements or limits as shown on the drawings. If the Contractor's operations result in damage to plantings or any other privately-owned facility outside the limitations of the construction easements or public right-of-way, the Contractor shall, at his/her expense, repair such damage or indemnify the owner of the damaged property.

If the Contractor negotiates with property owners for use of land for construction operations outside the limits of the construction easements, he/she shall do so at his/her own risk and the City will assume no liability for such use of private property. All agreements between the Contractor and private property owners shall be in writing. The Contractor shall commence no work outside the construction easements until copies of such agreements are furnished to the City.

10-1.12 PARTIAL PAYMENTS AND RETENTION

The Contractor's attention is directed to Section 9-1.06 Partial Payments of the Standard Specifications.

The Contractor shall submit Subcontractor and/or supplier's waiver of liens as required under Civil Code Article 8122-8138. The waiver shall be "conditional" before payment and "unconditional" after payment on forms set forth in the statute.

As provided in Section 22300 of the Public Contract Code and Section 10263 of the Government Code, Contractor may request that any retention to be withheld during the course of a project is paid to an escrow agent at the Contractor's expense. Should the Contractor make such request, it will be required that an appropriate

Escrow Agreement as provided in said government codes be fully executed prior to any payment of retention withheld or to be withheld. The City Engineer or his/her delegate is authorized to execute said Escrow Agreement on behalf of the City.

10-1.13 ARBITRATION

Your attention is directed to Section 9-1.22 "Arbitration," of the Standard Specifications. In the event of a dispute as to whether the conditions materially differ or do involve hazardous waste, the Contractor shall continue to proceed with all work to be performed under the Contract and shall retain all rights provided either by Contract or by law which pertain to the resolution of any dispute or protest.

Arbitration shall be initiated by a Complaint in Arbitration made in compliance with the requirements of said regulations. A Complaint in Arbitration by the Contractor shall be made not later than 180 calendar days after the date of service in person or by mail on the Contractor of the final written decision by the Department of the claim.

10-1.14 NOTICE OF POTENTIAL CLAIM

Section 9-1.04 "Notice of Potential Claim", of the Standard Specifications is amended to read:

Section 9-1.04 Notice of Potential Claim – The Contractor shall not be entitled to the payment of any additional compensation for any act, or failure to act, by the City Engineer, including failure or refusal to issue a change order, or for the happening of any event, thing, occurrence, or other cause, unless he/she shall have given the City Engineer due written notice of potential claim as hereinafter specified. Compliance with this section shall not be a prerequisite as to matters within the scope of the protest Provisions in Section 4-1.03, "Changes", or Section 8-1.06, "Time of Completion", or the notice Provisions in Section 5-1.116, "Differing Site Conditions", or Section 8-1.07, "Liquidated Damages", or Section 8-1.10, "Utility and Non-Highway Facilities", nor to any claim which is based on difference in measurements or errors of computation as to Contract quantities.

The written notice of potential claim shall be submitted to the City Engineer prior to the time that the Contractor performs the work giving rise to the potential claim for additional compensation, if based on an act or failure to act by the City Engineer, or in all other cases within 15 calendar days after the happening of the event, things, occurrence, or other cause, giving rise to the potential claim.

It is the intention of this section that differences between the parties arising under and by virtue of the Contract are brought to the attention of the City Engineer at the earliest possible time in order that such matters may be settled, if possible, or other appropriate action promptly taken. The Contractor hereby agrees that he/she shall have no right to additional compensation for any claim that may be based on such act, failure to act, event, thing or occurrence for which no written notice of potential claim as herein required was filed.

Should the Contractor, in connection with or subsequent to the assertion of a potential claim, request inspection and copying of documents or records in the possession of the City that pertain to the potential claim, Contractor shall make its records of the project, as deemed by the City to be pertinent to the potential claim, available to the City for inspection and copying.

Submission of a claim, properly certified, with all required supporting documentation, and written rejection or denial of all or part of the claim by owner, is a condition precedent to any action, proceeding, litigation, suit, or demand for arbitration by Contractor.

10-1.15 CLAIMS

Submission of a claim, properly certified with all required supporting documentation, and written rejection or denial of all or part of the claim by the City Engineer, is a condition precedent to any action, proceeding, litigation, sutor demand for arbitration by Contractor. The Contractor's attention is directed to Section 9-1.07B "Final Payment and Claims" of the Standard Specifications.

Payment for graffiti, if required, shall be borne by the Contractor, and no additional compensation shall be allowed therefore.

10-1.16 PUBLIC CONTRACTS CODE 9204 PUBLIC WORKS PROJECT

Contract Dispute Procedures

Sections 9204(e) and (g) of the California Public Contract Code ("PCC") provides that the text or a summary of PCC 9204, effective January 1, 2017, shall be included in the plans and specifications for any public works projects that may give rise to a claim under this section and that Section 9204 applies to contracts for public works projects entered into on or after January 1, 2017. In accordance therewith, City of Salinas hereby provides notice and includes the statutory text:

10-1.17 "9204.

(a) The Legislature finds and declares that it is in the best interests of the state and its citizens to ensure that all construction business performed on a public works project in the state that is complete and not in dispute is paid in full and in a timely manner.

(b) Notwithstanding any other law, including, but not limited to, Article 7.1 (commencing with Section 10240) of Chapter 1 of Part 2, Chapter 10 (commencing with Section 19100) of Part 2, and Article 1.5 (commencing with Section 20104) of Chapter 1 of Part 3, this section shall apply to any claim by a contractor in connection with a public works project.

(c) For purposes of this section:

(1) "Claim" means a separate demand by a contractor sent by registered mail or certified mail with return receipt requested, for one or more of the following:

(A) A time extension, including, without limitation, for relief from damages or penalties for delay assessed by a public entity under a contract for a public works project.

(B) Payment by the public entity of money or damages arising from work done by, or on behalf of, the contractor pursuant to the contract for a public works project and payment for which is not otherwise expressly provided or to which the claimant is not otherwise entitled.

(C) Payment of an amount that is disputed by the public entity.

(2) “Contractor” means any type of contractor within the meaning of Chapter 9 (commencing with Section 7000) of Division 3 of the Business and Professions Code who has entered into a direct contract with a public entity for a public works project.

(3) (A) “Public entity” means, without limitation, except as provided in subparagraph (B), a state agency, department, office, division, bureau, board, or commission, the California State University, the University of California, a city, including a charter city, county, including a charter county, city and county, including a charter city and county, district, special district, public authority, political subdivision, public corporation, or nonprofit transit corporation wholly owned by a public agency and formed to carry out the purposes of the public agency.

(B) “Public entity” shall not include the following:

(i) The Department of Water Resources as to any project under the jurisdiction of that department.

(ii) The Department of Transportation as to any project under the jurisdiction of that department.

(iii) The Department of Parks and Recreation as to any project under the jurisdiction of that department.

(iv) The Department of Corrections and Rehabilitation with respect to any project under its jurisdiction pursuant to Chapter 11 (commencing with Section 7000) of Title 7 of Part 3 of the Penal Code.

(v) The Military Department as to any project under the jurisdiction of that department.

(vi) The Department of General Services as to all other projects.

(vii) The High-Speed Rail Authority.

(4) “Public works project” means the erection, construction, alteration, repair, or improvement of any public structure, building, road, or other public improvement of any kind.

(5) “Subcontractor” means any type of contractor within the meaning of Chapter 9 (commencing with Section 7000) of Division 3 of the Business and Professions Code who either is in direct contract with a contractor or is a lower tier subcontractor.

(d) (1) (A) Upon receipt of a claim pursuant to this section, the public entity to which the claim applies shall conduct a reasonable review of the claim and, within a period not to exceed 45 days, shall provide the claimant a written statement identifying what portion of the claim is disputed and what portion is undisputed. Upon receipt of a claim, a public entity and a contractor may, by mutual agreement, extend the time period provided in this subdivision.

(B) The claimant shall furnish reasonable documentation to support the claim.

(C) If the public entity needs approval from its governing body to provide the claimant a written statement identifying the disputed portion and the undisputed portion of the claim, and the governing body does not meet within the 45 days or within the mutually agreed to extension of time following receipt of a claim sent by registered mail or certified mail, return receipt requested, the public entity shall have up to three days following the next duly publicly noticed meeting of the governing body after the 45-day period, or extension, expires to provide the claimant a written statement identifying the disputed portion and the undisputed portion.

(D) Any payment due on an undisputed portion of the claim shall be processed and made within 60 days after the public entity issues its written statement. If the public entity fails to issue a written statement, paragraph (3) shall apply.

(2) (A) If the claimant disputes the public entity's written response, or if the public entity fails to respond to a claim issued pursuant to this section within the time prescribed, the claimant may demand in writing an informal conference to meet and confer for settlement of the issues in dispute. Upon receipt of a demand in writing sent by registered mail or certified mail, return receipt requested, the public entity shall schedule a meet and confer conference within 30 days for settlement of the dispute.

(B) Within 10 business days following the conclusion of the meet and confer conference, if the claim or any portion of the claim remains in dispute, the public entity shall provide the claimant a written statement identifying the portion of the claim that remains in dispute and the portion that is undisputed. Any payment due on an undisputed portion of the claim shall be processed and made within 60 days after the public entity issues its written statement. Any disputed portion of the claim, as identified by the contractor in writing, shall be submitted to nonbinding mediation, with the public entity and the claimant sharing the associated costs equally. The public entity and claimant shall mutually agree to a mediator within 10 business days after the disputed portion of the claim has been identified in writing. If the parties cannot agree upon a mediator, each party shall select a mediator and those mediators shall select a qualified neutral third party to mediate with regard to the disputed portion of the claim. Each party shall bear the fees and costs charged by its respective mediator in connection with the selection of the neutral mediator. If mediation is unsuccessful, the parts of the claim remaining in dispute shall be subject to applicable procedures outside this section.

(C) For purposes of this section, mediation includes any nonbinding process, including, but not limited to, neutral evaluation or a dispute review board, in which an independent third party or board assists the parties in dispute resolution through negotiation or by issuance of an evaluation. Any mediation utilized shall conform to the timeframes in this section.

(D) Unless otherwise agreed to by the public entity and the contractor in writing, the mediation conducted pursuant to this section shall excuse any further obligation under Section 20104.4 to mediate after litigation has been commenced.

(E) This section does not preclude a public entity from requiring arbitration of disputes under private arbitration or the Public Works Contract Arbitration Program, if mediation under this section does not resolve the parties' dispute.

(3) Failure by the public entity to respond to a claim from a contractor within the time periods described in this subdivision or to otherwise meet the time requirements of this section shall result in the claim being deemed rejected in its entirety. A claim that is denied by reason of the public entity's failure to have responded to a claim, or its failure to otherwise meet the time requirements of this section, shall not constitute an adverse finding with regard to the merits of the claim or the responsibility or qualifications of the claimant.

(4) Amounts not paid in a timely manner as required by this section shall bear interest at 7 percent per annum.

(5) If a subcontractor or a lower tier subcontractor lacks legal standing to assert a claim against a public entity because privity of contract does not exist, the contractor may present to the public entity a claim on behalf of a subcontractor or lower tier subcontractor. A subcontractor may request in writing, either on his or her own behalf or on behalf of a lower tier subcontractor, that the contractor present a claim for work, which was performed by

the subcontractor or by a lower tier subcontractor on behalf of the subcontractor. The subcontractor requesting that the claim be presented to the public entity shall furnish reasonable documentation to support the claim. Within 45 days of receipt of this written request, the contractor shall notify the subcontractor in writing as to whether the contractor presented the claim to the public entity, and if the original contractor did not present the claim, provide the subcontractor with a statement of the reasons for not having done so.

(e) The text of this section or a summary of it shall be set forth in the plans or specifications for any public works project that may give rise to a claim under this section.

(f) A waiver of the rights granted by this section is void and contrary to public policy, provided, however, that (1) upon receipt of a claim, the parties may mutually agree to waive, in writing, mediation and proceed directly to the commencement of a civil action or binding arbitration, as applicable; and (2) a public entity may prescribe reasonable change order, claim, and dispute resolution procedures and requirements in addition to the provisions of this section, so long as the contractual provisions do not conflict with or otherwise impair the timeframes and procedures set forth in this section.

(g) This section applies to contracts entered into on or after January 1, 2017.

(h) Nothing in this section shall impose liability upon a public entity that makes loans or grants available through a competitive application process, for the failure of an awardee to meet its contractual obligations.

(i) This section shall remain in effect only until January 1, 2020, and as of that date is repealed, unless a later enacted statute, that is enacted before January 1, 2020, deletes or extends that date.”

10-1.18 DUST CONTROL

Dust Control shall be as specified in Section 10 of the State Standard Specifications, except as herein modified.

Payment for dust control shall be considered as included in the prices paid for the various Contract items of work as listed in the proposal, and no additional compensation shall be allowed therefore.

10-1.19 RECYCLING AND CLEANUP

Throughout all phases of work including suspension of work, and until final acceptance of the project, the Contractor shall keep the work site clean and free from rubbish and debris. Salinas Municipal Code 9-4.1 requires all Construction and Demolition (“C&D”) projects within the City to divert at least 50% of the C&D debris and 100% of inert materials generated by the project. All building and demolition project contractors must prepare and submit a C&D Waste Reduction and Recycling Plan prior to commencement of project and a final C&D Waste Reduction and Recycling Report to the City Engineer’s Office upon completion of the project. Further information can be found in Part E of this document. A copy of the instructions for preparing a C&D Waste Reduction and Recycling Plan can also be obtained from the City of Salinas Permit Center (65 W. Alisal Street, Salinas, CA 93901).

The Contractor shall also abate dust nuisance by cleaning, sweeping, and sprinkling with water, or other means as necessary. The use of water resulting in mud on public streets **will not** be permitted as a substitute for sweeping or other methods.

Failure of the Contractor to comply with the City Engineer's clean up orders may result in an order to suspend the work until the condition is corrected. **No additional compensation will be allowed as a result of such suspension.**

10-1.20 TRAFFIC CONTROL

10-1.21 GENERAL

All work shall be in accordance with Part 6 of the California Manual on Uniform Traffic Control Devices (“California MUTCD”), Contractor Shall maintain two-way traffic at all times, unless flaggers are provided to control traffic.

Contractor shall provide all signs, barricades, markers, striping, delineators, lights, and flaggers as required by the City Engineer.

Attention is directed to the California MUTCD. A current copy of the California MUTCD is available for free download via the California DOT website <http://www.dot.ca.gov/hq/traffops/signtech/mutcdsupp/>.

All work shall be in accordance with the Provisions in Section 12, “Construction Area Traffic Control Devices”; Section 7-1.08, “Public Convenience”; Section 7-1.09, “Public Safety”; and Section 4-1.04, “Detours”, of the Standard Specifications, the Provisions in Chapter 5, “Traffic Controls for Highway Construction”, of the CalTrans Traffic Manual. Contractor shall maintain two-way traffic at all times, unless flagman is provided to control traffic.

The Contractor’s attention is directed to the Provisions in Section 7-1.08, “Public Convenience”, of the Standard Specifications. The Contractor shall provide all signs, barricades, markers, striping, delineators, lights, and flagmen as required by the City Engineer.

The Contractor’s attention is directed to the Provisions in Section 7-1.09, “Public Safety”, of the Standard Specifications. The Contractor shall provide and install all necessary signs, fences, temporary K railings, barricades, lights, and other devices and take such other protective measures to prevent accidents or damage or injury to the public.

The Contractor’s attention is directed to the Provisions in Section 12, “Construction Area Traffic Control Devices”, of the Standard Specifications. All signs, lights, barricades, delineators, and other devices used for detouring and traffic control shall conform to the requirements within the Provisions in Section 12-3, “Traffic Devices”, of the State Standard Specifications.

The Contractor shall submit an Area Sign Plan and Detour Plan per the State Standard Plans, these Special Provisions, and City of Salinas “Channelization Devices Detail” and “Typical Lane Closure Detail” within Part E of the Special Provisions. **The City Engineer prior to the beginning of construction shall approve Sign Plan and Detour Plan.**

No streets shall be closed to thru traffic. All streets listed in this Contract shall be resurfaced on half street portions to provide access to thru traffic. No lane closures shall be allowed without an approved Access Plan showing barricading, signing, and necessary detour signing in accordance with the latest edition of the “Manual of Warning Signs, Lights, and Devices for use in Performance of Work Upon Highways” as published by the California Department of Transportation. Arterial streets **shall not** be impacted Monday thru Friday; 7:00-8:30 a.m. and 4:00-6:00 p.m.

The Contractor shall notify local authorities (City of Salinas Police and Fire Departments, Monterey-Salinas Transit, City of Salinas, etc.) and news media (radio, TV, and **all** local newspapers) of his/her intent to begin work at least **5 calendar days** before work is begun. The Contractor shall cooperate with local authorities relative

to handling traffic through the area and shall make his/her own arrangements relative to keeping the working area clear of parked vehicles.

Payment for all traffic detours and traffic control, including all required temporary construction signs and posts, lights, barricades, delineators, and other devices shall include all labor, materials, tools, equipment, all necessary hardware for signs, and other appurtenances required and shall be considered as included in the prices paid for the various Contract items of work as listed in the Proposal and no additional compensation shall be allowed therefore.

10-1.22 CHANGES IN WORK

For work done on a "Time and Materials" basis, the Contractor shall submit all required documents for a specific change within ten (10) calendar days of completing the work.

Outstanding proposals at the end of the project: The Contractor shall submit all outstanding proposals, in the specified format, within ten (10) calendar days of the date established as "Substantial Completion". The City reserves the right to not process any proposals received after that date unless specifically agreed in advance.

10-1.23 PRESERVATION OF PROPERTY

The Contractors attention is directed to the Provisions in Section 7-1.11, "Preservation of Property", of the State Standard Specifications, and these Special Provisions.

Existing trees, shrubs, and other plants, that are not to be removed, and are injured or damaged by reason of the Contractor's operations, shall be replaced by the Contractor in accordance with the requirements within the Provisions in Section 20-4.07, "Replacement", of the State Standard Specifications.

Damaged or injured plants shall be removed and disposed of outside the City of Salinas right-of-way in accordance with the Provisions in Section 7-1.13 of the State Standard Specifications. At the option of the Contractor, removed trees and shrubs may be reduced to chips. The chipped material shall be spread within the highway right-of-way at locations designated by the City Engineer.

Replacement planting of injured or damaged trees, shrubs, and other plants, caused by the Contractor/Staff shall be completed not less than 20 working days once agreed upon by the Engineer and the Contractor. Replacement trees, shrubs, and other plants shall be watered as necessary to maintain the trees, shrubs, and other plants in a healthy condition.

10-1.24 ENVIRONMENTAL/POLLUTION PREVENTION REQUIREMENTS

Contractor shall comply with all environmental pollution prevention regulations, ordinances, and statutes that apply to the project and any work performed pursuant to the contract. Salinas City Code Chapter 29-9 states:

"No person shall contribute or cause to be contributed, directly or indirectly, to the city's storm drainage system any pollutant, wastewater or any substance or material which will interfere with the operation or performance of the storm drainage system, violate the city's NPDES permit or violate other applicable law or regulations."

The Contractor shall comply with the City of Salinas NPDES Permit Order No. R3-2012-0005 and, if applicable, the State's current Construction Stormwater General Permit. Projects that disturb one or more acres of soil, or disturb less than one acre but are part of a larger common plan of development, are required to obtain coverage

under the General Permit for Discharges of Stormwater associated with Construction Activity, Construction General Permit Order No. 2012-0006-DWQ.

Construction activity subject to the CGP includes clearing, grading, and disturbances to the ground such as stockpiling or excavation, or construction activities associated with Linear Underground/Overhead Projects (“LUPs”). The City of Salinas NPDES permit also has additional requirements applicable to construction projects of any size.

10-1.25 MOBILIZATION

Mobilization shall conform to the Provisions in Section 11, “Mobilization”, of the State Standard Specifications.

Payment for mobilization shall be considered as included in the prices paid for the various Contract items of work as listed in the Proposal no additional compensation shall be allowed therefore.

SECTION 11 LANDSCAPE MAINTENANCE

SECTION 11-1 DEFINITIONS

For the purpose of this contract, the following terms and wordings have definitions hereinafter specified:

Hand-Sweeping – Removal of refuse by the use of hand tools including brooms and shovels. Compensation for Hand-Sweeping shall be considered as included in other items of work.

Refuse – All deposits of dirt, rock, glass, cans, leaves, sticks, papers, or any like materials so designated by the Engineer within the areas to be swept within the terms of this contract and of a size which can be practically removed by mechanical sweeping or hand-sweeping operations.

Engineer – Engineer of Public Works Department, or designated representative(s), City of Salinas.

City of Salinas BMPs for pesticide, herbicide, and fertilizer application, storage, and disposal, including the following:

- Training activities, permits, certifications, and other measures for municipal applicators and distributors;
- Integrated pest management measures that rely on non-chemical solutions for all municipal areas;
- Eliminating the use of pesticides and fertilizers within **48 hours** prior to a likely precipitation event or irrigation. A likely precipitation event is any weather pattern that is forecast to have a **50 percent or greater** probability of producing precipitation in the application area;
- Collection and proper disposal of unused pesticides, herbicides, and fertilizers;
- A standardized protocol for the routine and non-routine application of pesticides, herbicides (including pre-emergents), and fertilizers;
- Prohibition of storage or application of banned or unregistered pesticides;

- Implementation of procedures to encourage the retention and planting of native vegetation to reduce water, pesticide, herbicide, and fertilizer needs;
- Limiting or replacing pesticide use (e.g., manual weed and insect removal);
- Limiting or eliminating the use of fertilizers. Prohibition fertilizer application within 5 feet of pavement, 25 feet of storm drain inlet, or 50 feet of a water body;
- Reducing mowing of grass to allow for greater pollutant attenuation, but not jeopardizing motorist safety;
- Storage of pesticides and fertilizers indoors or under cover on paved surfaces or use of secondary containment;
- Reduction in the use, storage, and handling of hazardous materials to reduce the potential for spills;
- Regular inspection of storage areas;
- Prohibition of use of pesticides on the CWA section 303(d) list for any water bodies the Permittee's MS4 is tributary to; and
- Provide direct supervision by a pesticide applicator, certified in the appropriate category, of municipal employees or contractors applying restricted pesticides.
- Contractor shall not use pyrethroid pesticides. Alternate materials should be considered. Utilize BMP's to replace materials/chemicals with more environmentally benign materials or methods (e.g., use mechanical methods rather than herbicides).

A. Weed Control – General

1. At the discretion of the Engineer, weeds in all lawn areas, planting beds, planted islands, tree wells, shrub wells, parking lots, traffic islands, curb and gutters, sidewalks, and open space shall be removed or killed weekly as the weeds emerge. Weeds shall be mechanically removed (not just killed) if they are larger than 2 inches (5 cm) in height or diameter. Unsightly weeds throughout the Districts will be mechanically removed or prevented against throughout all districts.
2. All debris resulting from weeding operations shall be removed from the project area on the same day that the weeding operation occurs.
3. Should the Contractor desire to use a chemical weed control program, they shall develop said program and submit in writing to the Engineer within 15 days of approval of contract for review and approval. Said program shall be administered in accordance with applicable laws and practices governing the use of chemicals. Said program shall be adhered to unless written approval to change such program is granted by the Engineer. Weed oils, granular pellets or any other weed control materials shall be used only in strict conformance with Federal, State, County, and local regulations and codes. The materials must be approved by the Engineer.
4. The Contractor or the Pest Control Operator of the Contractor must have a valid certification appropriate to the pesticide application undertaken, and all weed control must have a written recommendation prepared by a Certified Pest Control Advisor, as required by the Monterey

County Agriculture Commissioner.

5. Any new or existing plants or soil which, in the opinion of the Engineer, have been damaged by applying or lack of applying weed control materials shall be replaced by the Contractor no later than one (1) week after notice of such damage at Contractor's expense.
6. Planter Maintenance: Complete trimming and cultivating of planters and ground cover shall be completed monthly. Weeding shall be performed regularly to avoid establishment of seedlings.

All vegetation shall be sprayed and removed for a distance of eighteen (18) inches from tree trunks to form tree wells. Any additional weed control in turf areas shall be as needed or as directed by the Maintenance Operations Manager or designee.

Weed control required and approved within turf areas by the Maintenance Operations Manager or designee is considered as part of contract.

7. Handling of Pesticides: Care shall be taken in transferring and mixing of pesticides to prevent contaminating areas outside the target area. Application methods shall be used to which ensure that materials are confined to the target area. Spray tanks containing leftover materials shall not be drained on the site. Disposal of pesticides and tank rinsing materials shall be within the guidelines established in the State of California Food and Agricultural Code or EPA regulations.
8. Timing: Pesticides shall be applied at times, which limit the possibility of contamination from climatic or other factors and at the proper life cycle of the pests. Early morning application shall be used when possible to avoid contamination from drift. Applicator shall monitor forecast weather conditions to avoid making application prior to inclement weather to eliminate potential runoff of treated areas
9. Contractor shall apply spray chemicals when air currents are still; preventing drifting onto adjacent property and preventing any toxic exposure to persons whether or not they are in, or near, the project.

B. Insect and Disease Control

1. The Contractor or the Operator must have a valid certification appropriate to the pesticide application undertaken, and all weed control must have a written recommendation prepared by a Certified Pest Control Advisor as required by the Department of Pesticide Regulation and the Monterey County Agriculture Commissioner.
2. The spray materials shall meet all Federal, State, County, and local requirements. The spray materials must be approved by the Engineer.
3. Any applications within 500 feet of any school shall not be made within one hour before or one hour after school hours, as required by applicable pesticide regulations.
4. The Contractor shall use a dormant spray fungicide that controls anthracnose and other plant diseases as needed.
5. The Contractor shall use an appropriate insecticide and fungicide spray that prevents or controls disease and insect infestations.

6. Application of insect and disease control materials shall be within the time best suited to the eradication of the insects and diseases.
7. Any new or existing plants or soil which, in the opinion of the Engineer, have been damaged by applying or lack of applying control materials shall be replaced by the Contractor within a week after notice of such damage at his expense.
8. Scheduled spraying shall be applied twice annually to all deciduous trees and shrubs. The first spraying shall be accomplished while trees or shrubs are in full dormancy. The second spray shall be applied just as the buds start to open. Contractor's choice of specific spraying times must be approved by the Engineer.
9. A program for control of insects and diseases shall be developed by the Contractor and Submitted with supporting manufacturer's data and submitted in writing to the Engineer within 15 days of the approval of the contract for the Engineer's review and approval.
10. Pesticides shall be stored, transported and applied only in strict conformance with Federal, State, County, and local regulations and codes. The materials must be approved by the Engineer in advance of the application.
11. If spraying cannot be performed for any reason, the contractor shall use tree injections to control infestations according to pesticide label.
12. Irrigation water applied after treatment shall be reduced to eliminate runoff. When water is required to increase pesticide efficiency, it shall be applied only in quantities of which each area is capable of receiving without runoff.
13. Contractor shall be responsible to update daily all pesticide, herbicide and fertilization applications to the City's PHF on-line app.

C. Ground Squirrel, Gopher and Other Rodent Damage Control

Contractor shall repair all rodent damage. All fresh mounds are to be removed and rodents eradicated within four (4) days by the Contractor in planted areas and seven (7) days in non- planted areas. All rodent damage done to turf areas shall be leveled out and re-sodded to match existing grade. All damage done to existing plant material by rodents shall be replaced by contractor with new plant material.

Rodent Control—Contractor shall keep all turf and landscaped areas free of gophers by using Macabee gopher traps or other devices approved by the contract manager. **Rodenticide use is not allowed.**

D. Debris, Graffiti and Litter Removal

Areas:

1. All debris and litter shall be removed by the Contractor from all project areas within two (2) days (twice a week) of deposit. Debris and litter removal shall be disposed of immediately by Contractor.
2. Debris and litter to be removed shall include but is not limited to all debris generated by the work included in this project, paper, glass, trash, leaves, pine needles and all other forms of debris and

litter from all sources including those outside the project site.

3. Contractor shall remove “graffiti” or other unsightly markings placed upon visible faces including, but not limited to, cinder block walls, bench seats, picnic tables, irrigation/lighting boxes, light poles, tree trunks, sidewalks, and any other surface within the district boundary within the next working day during the term of this contract. Graffiti removal shall be considered as part of regular maintenance activities and shall not be compensated as additional work.
4. Complete policing; litter pickup and supplemental hand sweeping of parking lot corners, street medians, storm drain grates and areas along gutters/curbs inaccessible to power equipment shall be accomplished to ensure a neat appearance.
5. Contractor shall dump all trash receptacles located throughout the Landscape District. This also includes installing plastic bags as needed, contractor supplied.

E. Signs/Improvements

Contractor shall not post signs or advertising material upon the site premises unless prior approval is obtained from the inspector.

Contractor will remove all advertisements and election signs from the work site, including from utility poles and trees, each time site is serviced. Signs shall be stored by contractor until City staff gives approval for their disposal.

F. Removal of Dead, Damaged, or Diseased Plant Materials

Contractor shall remove dead, severely damaged or diseased plant material no later than seven

(7) days after identification. Broken tree limbs or other items that may cause hazardous conditions to the public shall be removed immediately.

G. Staking and Guying

1. Newly planted trees shall be kept adequately staked at all times. Ties shall be loosened periodically to prevent girdling. A detailed drawing of the staking system to be used is included in Appendix “A”, Street Tree Planting Plan.
2. Newly planted trees shall not be left unstaked for more than two (2) working days, unless written permission is granted by the Engineer.
3. Trees that have reached a size and stability so as not to require staking shall be exempt from these requirements upon the approval of the Engineer. Trees under the size of a standard 5 gallon size for the variety shall also be exempt from these requirements unless otherwise required by the Engineer.

H. Inclement Weather

1. During the periods when inclement weather hinders normal operations, the Contractor shall adjust

his work force in order to accomplish those activities that are not affected by weather.

2. The Contractor shall re-stake, re-tie or remove trees or other such activities as required as a result of inclement weather. The Contractor will stay available to assist in any storm related damage repair to sites in this contract.
3. Contractor shall not work or perform any operations during inclement weather that may destroy or damage ground cover or turf areas. The Contractor shall contact the Maintenance Operations Manager or designee for the determination of non-operation conditions.
4. The Contractor shall immediately notify the Maintenance Operations Manager or designee when the work force has been removed from the job site due to inclement weather or other reasons.

I. Fire Prevention

Contractor shall take all precautionary measures to ensure that while working with (power equipment, vehicles, etc.) in weeded or grassy areas they do not start a fire. All contractor vehicles shall be equipped with fire extinguishers.

The City of Salinas shall not be held liable for any fires due to contractor negligence.

J. Irrigation of Plant Materials

1. All planted areas shall be watered deeply as weather conditions require to promote normal growth and insure the health of the vegetation therein. Water for the irrigation systems shall be furnished by the City. Water usage shall be in accordance with the City's water conservation Ordinance No. 2123. Lawns at no time shall show a lack of fresh green color or a loss of resilience due to a lack of water.

Control watering to prevent runoff and/or erosion, puddling, or over watering. Prevent watering roadways, walkways or private property. Provide adequate coverage of all landscape areas. Match precipitation rates. Limit hazardous conditions. Adjust irrigation as required due to seasonal changes and rain. A current schedule of automatic watering cycles must be provided to the Engineer's representative upon request. Automatic controllers shall be set to operate irrigation systems between 9:00 p.m. and 5:30 a.m., or as directed by the Engineer.

2. Emergency irrigation not conforming to the City's Water Conservation Ordinance will require prior approval by the Engineer prior with notification to the water purveyor of the time, location and reason for the non-conforming irrigation.
3. All irrigation systems shall be tested and inspected and a written report submitted to the City when requested.
4. All irrigation systems shall be tested and inspected as necessary when damage is suspected or observed, or reported daily if necessary.

Battery operated controllers will be kept in continuous operating condition by replacing batteries

when necessary at Contractor's expense.

5. All replacements shall be in strict accordance with City of Salinas equipment and installation standard plans, no substitutions will be permitted.
6. Unplug all clogged heads, flush lines free of rocks, mud and debris.
7. Contractor shall maintain all irrigation systems in a manner that shall assure correction or malfunction and allow their use in a manual or automatic condition within two (2) working days after identification of malfunction. All valve boxes, valves, vacuum breakers, hydrants, and sprinklers shall be kept clear of debris and vegetation. Contractor is responsible for cost to repair or replace irrigation systems which malfunction due to Contractor's negligence.
8. The payment for the repair and maintenance of the irrigation systems shall be considered as included in the monthly price paid for landscape maintenance and no separate payment shall be made therefor. The prices paid shall include full compensation for furnishing all labor, materials, tools, and equipment and doing all work involved as specified. Major irrigation repairs, such as repairing control valves, controllers, vacuum breakers, and backflow preventers, shall not be considered as normal maintenance for the purpose of billing. Contractor shall obtain approval from the City before incurring expenses for major irrigation repairs. Contractor may replace any malfunctioning portion of the irrigation system with the same or a substitute type of product or operation with prior consent of the Engineer.
9. Major irrigation repairs, such as replacement of defective remote control valves, major controller repairs, major backflow prevention unit repairs, extensive wiring, repairs to the irrigation mainline, or any other single major irrigation repair project, which necessitates costs for materials in excess of \$150, shall not be considered as normal maintenance for the purpose of billing. Contractor shall obtain approval from the Engineer before incurring expenses for major irrigation repairs.
10. In the event of a malfunctioning remote control valve, the Contractor shall be responsible for manual watering by utilizing the use of a water truck or water bubble, hand bleeding remote control valves, setting out additional hoses and sprinklers, and/or hand watering as required to uniformly irrigate affected areas until said valve is repaired.
11. Controller enclosures shall be maintained by the Contractor at no extra cost to the City. This maintenance shall include rust removal, painting, sealing, or other measures which are intended to preserve the controller enclosure. Any replacement of the controller box necessitated by vandalism or deterioration, after all reasonable efforts have been made by the contractor to preserve the enclosure will be paid for as extra work.
12. Contractor shall keep irrigation controllers securely locked at all times when they are not required to be open for programming, repairs, or checking the operation of the controller.
13. Controllers shall be checked at least weekly to assure proper operation and programming.

K. Water Conservation

Contractor shall, whenever possible, minimize the use of water during maintenance operations. Watering equipment shall be kept in good working order; water leaks shall be repaired promptly; and washing of equipment, except when necessary for the safety of and for the protection of equipment, shall be discouraged. In no case shall the Contractor use water to rinse or flush chemicals of any kind from equipment onto the work site and/or drainage or sewage systems.

Drought Impact on Irrigation: The Contractor shall comply with all water use regulations and restrictions. In addition, Contractor shall comply with City directed changes in irrigation in response to drought conditions.

L. Underground Excavations

Contractor shall be responsible for locating all underground utility lines to insure the safety of his/her work crew and to protect in place existing utility equipment before commencing any excavation. Contractor shall contact the Maintenance Operations Manager or designee and Underground Service Alert (1/800-227-2600) 48 hours before commencing any excavation, to locate underground service lines.

M. Fertilizing

The contractor shall provide ten (10) days advance written notice to Engineer of each intended application of fertilizer.

Lawn and All Types of Ground Cover. Commercial fertilizer shall conform to the provisions of Section 20 of the City of Salinas, Standard Specifications Design Standards, 2008. Fertilizer shall be a complete fertilizer, part if the elements of which are derived from organic sources; and shall have a guaranteed analysis of:

Element	Minimum
Nitrogen	16%
Phosphoric Acid	6%
Water Soluble Potash	4%

and shall be applied at such a rate to insure one pound of actual nitrogen per 1,000 square feet of area per application or as approved by the Engineer. Turf fertilizer shall be applied a minimum of three (3) times during the growing season, two (2) times per growing season for other planted areas to maintain healthy, vigorous growing conditions of all plants at all times.

1. Trees and Shrubs – Fertilizer tablets shall be 21-gram size with a guaranteed analysis of, or a departmentally approved equivalent product:

Nitrogen	20.00%
Phosphoric Acid	10.00%
Water Soluble Potash	5.00%
Combined Sulfur	1.60%

Iron

0.35%

and shall be applied at the following rate:

One tablet for each one-half inch of tree trunk diameter (tree trunk diameter shall be measured within six inches of the ground line) or three tablets per tree, whichever is greater, inserted up to two feet deep, but not less than 8 inches deep, equidistant round the dripline at the end of March each year.

One tablet for each shrub shall be inserted up to two feet deep, but not less than eight inches deep, near each shrub at the end of March of each year

N. Tree Work – Shall be considered Extra Work.

Staff - Any personnel engaged in the pruning of City of Salinas urban forest trees must be authorized to do so by the Director or an Urban Forestry designated representative. Prior to pruning please contact the City of Salinas Parks and Forestry Division. All personnel engaged in pruning operations shall do so under the supervision of an International Society of Arboriculture (ISA) Certified Arborist. Prior to approval of any tree pruning operation, it shall be the responsibility of the Contractor to provide the City of Salinas with proof of current ISA Arborist Certification for staff engaged in project supervision. Inspection of project work will be done by Urban Forestry Division staff members, designated by the Director.

1. Schedule – No tree work shall commence before 7:30 a.m. Crews are prohibited from working beyond dusk.
2. Health Maintenance – Removal of dead, diseased or hazardous limbs.
3. Structural – Pruning to maintain the strength and shape.
4. Safety – Prune to prevent wind damage and protect the public or adjacent property. No tree limbs shall protrude into vehicle roadways or streets below fourteen (14) feet from the ground and no tree limbs shall be less than nine (9) feet from the ground overhanging walkway. Clearance shall be as determined by the Engineer in all other areas.
5. General Pruning – No “stubbing” cuts shall be allowed. Any deadwood shall be removed to the point of attachment. Final cuts shall be made in such a way as to retain the bark collar without leaving a stub or cutting into the collar. When removing a dead branch, pruning cuts shall be made outside the callus tissue that has begun to form around the branch. All limbs two inches in diameter or over must be precut to prevent splitting. If splitting does occur, the wound shall be traced.
6. Crown Thinning – Pruning to thin crowns of trees shall be undertaken with the purpose of opening a tree to light, reducing weight on limbs, decreasing the wind sail effect, invigoration of the growth of the tree, and to increase the overall structural stability of the tree. Thinning operations should conform to ISA Standards provided in “Attachment A”.
7. Crown Reduction – Crown reduction shall be completed to reduce the overall height and spread of the trees. The goal of this pruning operation is to enhance the structural integrity of the trees designated for the pruning operations. No tree shall have more than 1/3 of the canopy removed in this pruning operation without prior approval of the City Engineer or the designated Urban Forestry staff representative. All crown reduction shall be performed in conformance with the ISA Pruning

Standards included as Appendix A.

8. Crown Restoration – Structural integrity shall be enhanced through crown restoration pruning. A natural appearing crown shall be developed through pruning which is done to a lateral to control the tree's growth to wood which is securely attached to healthy wood. It is anticipated that this process is one which requires an initial pruning with additional follow-up prunings to direct and accomplish a complete crown restoration project. All crown reduction shall be performed in conformance with the ISA Pruning Standards.
9. Clearance Pruning – Limbs growing in the direction of adjacent structures shall be pruned to minimize conflict with the structures (i.e. street signs). Lower limbs, suckers, and hanging foliage shall be raised to approximately Fourteen (14) above the street for traffic clearance, and 9 feet above sidewalks and lawns for pedestrian access. Deviation from clearance height requires approval of the Public Works Engineer or designated Urban Forestry staff representative. Immature specimens may require an adjustment appropriate to the individual tree size and stage of growth.
10. Miscellaneous
 - a. Pruning sealant or paint is not required, or allowed, on pruning cuts.
 - b. Trees which are infected with a disease shall require removal of all infected limbs to a point in the limb at least 6 inches below the diseased area. Any tree found to be fully infected with a disease shall be inspected by the designated Urban Forestry staff member prior to any pruning which would reduce the size of the infected tree substantially or require removal of the tree.
 - c. Height – Prune to specific height as directed by the Engineer.

O. Hedge Trimming

1. All hedge and ground cover plants growing in the subject areas shall be trimmed and pruned, to maintain plants in a healthy, growing condition and to maintain plant growth, within reasonable bounds as determined by the Engineer, and to maintain uniform height to prevent encroachment of passageways, walks and streets, and to provide adequate view of signs and vision for vehicular traffic. Dead or damaged limbs or branches, trees or shrubs shall be removed immediately, and all pruning cuts shall be made cleanly with sharp pruning or hedging tools with no projections or stubs remaining. All cuttings, branches, and leaves shall be removed and disposed of before the end of the workday. Traffic signs, cones, etc., shall be used in accordance with City Standards.
2. Site Clean-Up
 - a. Disposal – All disposal of material generated from the pruning operations is the sole responsibility of the Contractor engaged in the operation. This shall include wood, foliage, and other organic material. Dust and dirt shall be kept to a minimum during the pruning process and shall be removed at the end of each day's operations or at the completion of work at individual sites prior to the Contractor leaving the site. No wood shall be left at the site of work unless prior approval of the Engineer or designated representative has been obtained. The costs of disposal of all wood and other debris generated by the project is included in the cost of the project costs and shall not be declared as additional costs to the project.

3. Signage – The Contractor shall furnish and install all safety street signs, cones, and other facilities, which are necessary to expedite the passage of public traffic through or around the work. This is to prevent accidents, damage, or injury to the public, and to give adequate warning to

vehicle or pedestrian traffic or to the public of any dangerous conditions to be encountered.

4. Sound Control Requirement – The Contractor shall comply with all local sound control and noise level rules, regulations, and ordinances which apply to any work performed pursuant to the Contract.

P. Trimming Edging

1. All lawns shall be trimmed and edged around irrigation systems, fire hydrants, tree wells, shrub basins, along ground cover, and curbs/sidewalks every week from March through October and every month from November through February.
2. Grass shall be trimmed around sprinkler heads as necessary to provide the maximum water coverage of spray nozzles. Removal of turf from around sprinkler heads will not be permitted.
3. Damage to sprinklers, headers, irrigation and utility boxes, and other structures shall be avoided. All damage to shall be reported to the Engineer’s representative and contractor shall make repairs promptly.

All debris generated by edging shall be removed from the project site by the end of the working day. All trimming and debris shall be raked from all planted and unplanted areas and shall be disposed of off-site by the Contractor. Costs for same are to be included in the routine maintenance fee.

4. All ground cover shall be trimmed to the inside edge of planting areas when ground cover grows three inches outside planting areas.

Contractor shall exercise care not to spray tree trunks with any chemicals or injure the tree trunk with any chemicals or injure the tree trunks with mechanical equipment. Trim lawn edges or tree wells with power edgers or by hand, but in no case will soil sterilents be permitted.

Q. Mowing

1. Ground cover plants other than lawns, e.g. ivy, hypericum, etc., shall be mowed once each year in the appropriate season to a height of three inches from ground level.

Ground cover plants shall be edged along curbs and planter edges so that no more than 4” of growth extends beyond the planter areas.

2. Lawn area shall be mowed at 2” height once every week from March through October; once every other week from November through February.
3. Lawns shall be renovated yearly by aerating and/or verti cutting. This shall be done during the

spring. If required for optimum water penetration, repeat as needed. Reseed bare areas as needed.

4. All mowing equipment shall be kept in good repair with cutting surfaces sharpened to ensure a clean and effective cutting of grass blades.
5. All mowing equipment shall be free of leaking fluids which would adversely affect the health of turf or other surfaces within the areas of responsibility.
The Contractor shall submit a mowing schedule of days and times for each designated park and landscape site. The Contractor shall maintain the schedule as closely as possible unless a change is authorized or directed by the Maintenance Operations Manager or designee. Should weather or site conditions prove to be prohibitive to the regularly scheduled mowing, Contractor shall contact the Engineer to reschedule the mowing service to a time and date acceptable to the Engineer. The Contractor shall not be compensated for mowing services which have not been provided, either through a regularly scheduled mowing or an acceptable rescheduled dated approved in advance by the Engineer.

In case of equipment failure Contractor shall notify the inspector of the failure immediately and reschedule that week's service to be completed within two days of said failure upon approval of Inspector.

Turf clippings and debris shall be lifted the same day of each mowing, trimming or edging operation and shall be removed from each district and landscape site. The use of mulching mower blades is acceptable as long as large amounts turf clippings are not impeding on normal turf growth.

R. Hauling

1. Spillage resulting from hauling operations on or across public thoroughfares shall be immediately removed at Contractor's expense.
2. If the spillage is of a hazardous substance, such as petroleum products, or pesticides, Contractor is required to contact the Maintenance Operations Manager or designee immediately and also prevent the substance from running into storm drains.

S. Playground inspections

Contractor shall perform daily, weekly and monthly playground inspections:

1. Daily-This includes checking for broken glass, graffiti, trash, or other foreign objects. Empty all trash receptacles. Check playground for major hazards. Daily cleaning of barbecue pits including emptying ash pales.
2. Weekly-Playgrounds with loose fill surfacing shall have minimum of 12 inches of fill placed under all swings, slides and major play equipment. Keep play area free of vegetation. (No Pesticides or Herbicides allowed in play area.)
3. Monthly- Check all play structures: Footings (loose, cracked), All moving parts for wear, rust, broken or missing parts (s-hooks, grommets, chains), and vandalism. Check all handrails, floors, steps, fasteners for excessive wear or damage.
4. Contractor shall be responsible to secure broken equipment until replacement or repair is completed.
5. Contractor shall report any findings immediately to Engineer.
6. Contractor shall supply daily, weekly and monthly inspection reports (checklist) to the City at the end of each month for each individual playground. This also includes exercise equipment and horseshoe

pits areas.

SECTION 11-2 HAULING

The payment for hauling shall be considered included in the various items of work, and no additional compensation will be allowed therefore.

SECTION 11-3 UNSUITABLE MATERIAL

The excavation and removal of additional unsuitable materials beyond the depths of excavations at site, and additional backfill, if required by the City Engineer, shall be in accordance with Section 19-2.02 of the Standard Specifications.

SECTION 11-4 PAYMENT

Payment for Excavation shall be as included in the various items of work and shall include: Compaction of native soil, disposal and all other work necessary except unsuitable material to attain the completed conditions contemplated in this project shall be included under the various items of work in the Proposal, and no additional compensation shall be allowed therefore. Unsuitable Material shall be paid for under Section 19-2.02 of the Standard Specifications. Hauling of excavated materials shall be as included in the Contract price paid for various items of work listed in the Proposal, and no additional compensation shall be allowed therefore.

SECTION 12 TEMPORARY TRAFFIC SIGNAGE

SECTION 12-1 GENERAL

All work and materials for signs shall conform to the Provisions in Section 56 of the Standard Specifications, these Special Provisions, California 2014 California Manual on Uniform Traffic Control Devices, and as shown on the Plans. The Contractor shall furnish all mounting hardware. Signs shall be constructed of 0.080" thick aluminum alloy.

SECTION 12-2 TEMPORARY TRAFFIC SIGNS

All temporary traffic signs shall have Diamond Grade 3-M reflective sheeting (or approved equal by the City Engineer). The reflective sheeting shall conform to the Federal Specifications L-S300A.

The Contractor shall remove all temporary traffic signs, hardware, and posts when the work is complete.

SECTION 13 BLANK

SECTION 14 CONTROL OF WORK

SECTION 14-1 GENERAL

- A. Damages to Existing Facilities – Plant materials, portions of existing structures or facilities, including irrigation systems, which are damaged or altered in any way during the performance of work in this project, shall be immediately repaired or replaced in kind by the Contractor at their expense and in a manner approved by the Engineer.

- B. Emergency Call – Contractor shall respond to emergency calls for matters covered by this contract immediately without additional cost to the City. Contractor shall furnish the department with names and phone numbers of personnel available for emergency call-out purposes.
- C. Lock and Keys - The Contractor shall be responsible for the series of 3 keys assigned to it and shall assign these keys to its personnel for use in maintaining the facilities. The Contractor shall properly use and keep safe all keys or locks issued by the City to the Contractor. The Contractor shall report all lost or stolen keys or locks to the City within 24 hours of discovery. The Contractor shall reimburse the City for the total cost of replacement keys and/or locks that have been lost.

SECTION 14-2 PAYMENT OF LANDSCAPE MAINTENANCE

- A. Each month, the Contractor shall submit one invoice for payment as described in Section – “Progress Payments”, of these Special Provisions for payment for all work performed during the previous month. Payment shall be made on receipt of said invoice at the contract unit price per month for landscape maintenance of subject areas. Department pre-approval must be granted prior to work which ultimately shall be billed as separate payment items, except in the case of emergency repairs. If the invoice submitted by Contractor exceeds the contract unit price per month for landscape maintenance, Contractor shall also submit invoices verifying the purchase of materials, labor, and a clear description of the location of the installation(s), type of work done, and the date of the work.
- B. The price paid per month for landscape maintenance at each area shall include full compensation for labor, tools, equipment, and materials for landscape maintenance of each area, including weed control, scheduled spraying for insect and disease control, debris and litter removal, removal of dead, damaged, or diseased plant materials, staking and guying, irrigation of plant materials, fertilizer, pruning, edging, trimming, mowing, maintenance and repair of the irrigation system. The price paid shall not include compensation for repair of irrigation systems when the system malfunctions as a result of Contractor negligence.

At the request of the Engineer, the Contractor shall perform such work or repairs and replacements associated with the maintenance of the area that is not covered under the basic services under the terms of this contract. Extra services shall be performed according to a quotation submitted by the Contractor, approved by the Engineer, or shall be done on a time and

material basis. Compensation for extra work shall be made in accordance with the specified amount approved in this contract. No mark-up for handling fees or other fees beyond the basic labor and materials cost is allowable. The Contractor shall obtain written approval from the Engineer before proceeding with the work. The quotation shall show a complete breakdown of all labor and material costs.

- C. Monthly Payments - The Contractor shall submit one invoice for payment in proper form to the City for all work performed during the previous month within five (5) calendar days following the last day of the previous month. The invoice shall list the area maintained and the date of the service with a total for all areas maintained during that month. Compensation will not be made for services not provided, as per Section 9 Work Description. If the invoice submitted by the Contractor exceeds the contract unit price per month for maintenance services, the Contractor shall also submit proof of approval to proceed from Engineer along with invoices of the location and scope of the services provided. The invoice shall indicate the areas in which work was performed, the dates upon which work was done, and the type of service provided. Work resulting in separate and additional billing

requires prior departmental approval before incurring costs

- D. Invoices for payments shall be submitted to:
- City of Salinas, Attn: Maintenance Manager
 - Public Works Department
 - 426 Work Street
 - Salinas, CA 93901

Invoice shall be received within five (5) calendar days following the last day of the previous month.

- E. After completion of the term of this contract and of all work called for under the contract and the value thereof, the City shall pay the entire sum so found to be due after deducting there from all previous payments and all amounts to be retained under the provisions of the contract. All prior partial estimates and payments shall be subject to correction in the final estimate and payment.

The final payment shall be in no way construed as an acceptance of any defective work. The Contractor agrees that the tender of the final payment by the City and acceptance thereof by the Contractor shall release the City, the Governing Body, the Engineer, and all other officers and employees of the City from any and all claims for liability or further payment on account of work done under the contract or alterations, additions, or reductions thereof.

SECTION 14-3 SCHEDULE OF WORK

- A. Schedule of Work – The Contractor’s schedule for carrying out the work as specified shall be submitted to the Engineer for review and approval prior to the award of the contract by the City. The schedule shall include the time, days, and areas to be maintained.
- B. The Progress and Standard of Quality of Work – The progress and standard of quality of work to be accomplished under this contract shall be of high quality. In the event of unsatisfactory maintenance as determined by the Engineer, Engineer shall require Contractor to correct the unsatisfactory work at no additional cost to the City for expenditures incurred in making the correction.

14-3.01 WORK SCHEDULE

1. The Contractor shall deliver to the City a complete landscape maintenance weekly work schedule along with the size of work crew and equipment summary sheet, prior to start of the maintenance contract.
2. The City retains the right to have certain work sites maintained on certain days.
3. Contractor is expected to have the same maintenance work crew assigned to its work sites at all times on a continuous basis.
4. Contractor at no time shall leave a work site to complete another sections project, without having completed the work assignment for that day.
5. No blowing in residential areas before 8:00 am.

SECTION 14-4 INSPECTIONS

- A. Inspections – Monthly inspections of the project site shall be scheduled by the City’s authorized representative. This site inspection shall require that both the Contractor and City representative review the progress and satisfaction of the work product and to plan any work necessary to meet the landscape maintenance. Deficiencies noted during inspections shall be fixed as soon as possible, but in no case will the same deficiency be tolerated on the next monthly inspection.
- B. Should the Contractor fail to correct maintenance deficiencies within the first month of observation by the designated City staff project inspector, a payment reduction of an amount up to 25% of the total monthly maintenance fee may be withheld. In the event the Contractor fails to correct said deficiencies within the next month’s billing period, the City may then retain an additional amount, up to 35% of that month’s regular maintenance fee. Failure to correct deficiencies may result in termination of this contract.
- C. Deficiency Notice The Contractor is required to correct deficiencies within the time specified by the City of Salinas. If the deficiency is not corrected within the time specified by the City, City labor will be called out to complete the work. Such work shall be done on a force account basis with an additional call out charge of \$75.00 per hour for each call-out. Call-out of City forces during off hours, resulting from improper programming of sprinkler controllers, will be charged to the Contractor at time and a half. It also should be noted that there is a minimum two-hour charge for labor on any call-out.

SECTION 15 MEASUREMENT AND PAYMENT

Payment for all labor, materials, tools, equipment and other appurtenances required for the proper, substantial and complete-in-place project construction for LANDSCAPE SERVICES FOR THE MONTE BELLA MAINTENANCE DISTRICT, as shown on the Plan and/or outlined in these Special Provisions.

Except for authorized changes in the work, payment for said complete-in-place finished work or improvement shall be made only on the basis of the Contract item of work listed in the Proposal. The various Contract item prices paid for the work required, for LANDSCAPE SERVICES FOR THE MONTE BELLA MAINTENANCE DISTRICT, complete-in-place, including full compensation for furnishing all labor, materials, tools, equipment and incidentals, for doing all the work involved in removing and disposal of various items of materials, provided for in these Specifications and Contract, or required for the proper completion of the work as a whole, for which no separate payment has been provided shall be a supplementary obligation for the Contractor and payment therefore shall be considered included in the price paid for the Contract item of work listed in the Proposal.

Reference Section 9-1.06 (page 9-11) of the Standard Specifications. Delete the last paragraph on page 9-11 and continuing first paragraph on page 9-12 and substitute the following:

The Contractor shall submit Subcontractor and/or suppliers waiver of liens as required under Civil Code Article 8122-8138. The waiver shall be “conditional” before payment and “unconditional” after payment on forms set forth in the statute.

The Contractor shall submit the progress payment pay application to the Engineer for review and approval. The Engineer shall review it within seven (7) calendar days of receipt. The Engineer shall either deny and return the progress payment pay application to the Contractor for correction, or recommend approval and forward it

to the Agency for processing. The required attachments to the monthly progress payment pay application shall include:

- A. Certified Payroll Reports: All current payroll reports and statement of compliance for the Contractors and all subcontractors (to be completed through the date of pay application).

Daily Reports: All current Daily Reports for the Contractor and all subcontractors and owner operators. Daily reports shall contain the name, classification and detailed task listing of all personnel and equipment, including all subcontractors and owner operators (to be completed through the date of pay application).

- B. Quantity Calculations: Certified quantity calculations to justify all pay quantities and amount requested.
- C. Monthly Schedule: The contractor shall submit an updated, revised construction schedule to the Engineer with each pay application.
- D. Unconditional Waiver of Lien Releases: The contractor shall submit Subcontractor and/or supplier's waiver of liens as required under Civil Code Article 8122-8138. The waiver shall be "conditional" before payment and "unconditional" after payment on forms set forth in the statute.

Failure to provide any of the documents as listed above will result in the Engineer returning the monthly pay application to the Contractor with no action.

Payment for all labor, materials, tools, equipment, and other appurtenances required for the proper, substantial and complete-in-place for the project as shown on or outlined in these Special Provisions.

**PART E -
CONSTRUCTION SITE BEST MANAGEMENT PRACTICES,
CONSTRUCTION AND DEMOLITION DIVERSION
REQUIREMENTS, EROSION AND SEDIMENT CONTROL
PLAN REQUIREMENTS AND OTHER MISCELLANEOUS
INFORMATION**

Handling Materials & Wastes

- ✓ Practice Source Reduction- minimize waste when ordering materials. Order only the amounts needed to complete the job.
- ✓ Use recycled and recyclable materials whenever possible.
- ✓ Never bury waste materials or leave them in the street.
- ✓ Dispose of all waste properly. Many construction materials, including solvents, water-based paints, vehicle fluids, broken asphalt and concrete, wood, and cleared vegetation can be recycled. Nonrecyclable materials must be taken to an appropriate landfill or disposed of as hazardous waste. For disposal information, call the numbers listed in this pamphlet.

Disposal Options

Use a crushing company to recycle concrete, asphalt and porcelain rather than taking them to the landfill. Call:

Recycling & Hazardous Waste Disposal:

Sun Street Transfer Station
Salinas Valley Solid Waste Authority
(831) 424-5520
139 Sun Street
Salinas, 93901

To Report a Spill, Illegal Dumping or a Clogged Storm Drain Call:

(831) 758-7233
City of Salinas
Department of Public Works
Maintenance Division

This is one in a series of pamphlets describing storm drain protection measures. Other pamphlets include:

- Automotive Maintenance & Car Care
- Equipment Rentals
- Food Service Industry
- Fresh Concrete & Mortar Application
- Heavy Equipment & Earthmoving Activities
- Home Repair & Remodeling
- Landscaping, Gardening & Pest Control
- Mobile Washers and Cleaners
- Painting
- Roadwork & Paving
- Swimming Pool, Jacuzzi & Fountain Maintenance

Stormwater Best Management Practices (BMPs): General Construction & Site Supervision



Safe Environmental Habits and Procedures for:

- General Contractors
- Construction Inspectors
- Home Builders
- Developers
- Masons & Bricklayers
- Sidewalk Construction Crews



City of Salinas

Permit Center

65 West Alisal St., Suite 101
Salinas, California 93901
(831) 758-7251

For more information about storm drain protection or additional pamphlets, call:

(831) 758-7233
City of Salinas
Department of Public Works
Maintenance Division

DETAIL B

City of Salinas
Permit Center

65 West Alisal St., Suite 101

Salinas, California 93901

(831) 758-7251

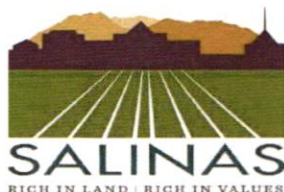

Stormwater Best Management Practices (BMPs):

General Construction and Site Supervision

Safe Environmental Habits and Procedures for:

- General Contractors
- Construction inspectors
- Home Builders
- Developers
- Masons and Bricklayers
- Sidewalk Construction Crews

Water Pollution Prevention It's Up to Us:



Only "Stormwater" is allowed in our storm drain system. This pamphlet tells you how to prevent waterway pollution from "Stormwater" or "urban runoff."

Rain, industrial and household water mixed with urban pollutants creates Stormwater pollution. The pollutants include: oil and other automotive fluids, paint and construction debris, yard and pet wastes, pesticides and litter.

Urban runoff pollution flows through the storm drain to the Salinas River and the Reclamation Ditch that takes water and debris straight from Salinas streets to the Monterey Bay Marine Sanctuary. Each day, polluted urban runoff enters our rivers untreated, leaving toxic chemicals and trash to be carried downstream.

Urban runoff pollution contaminates our rivers, and ditches, harms aquatic life and increases the risk of flooding by clogging gutters and catch basins.

Utilizing Best Management Practices (BMPs) will ensure cleaner receiving waters and a cleaner City.

REMEMBER: ONLY RAIN DOWN THE DRAIN!!!!

General Construction Problems

Construction sites are common sources of urban runoff pollution. Materials and wastes blown or washed into a street, gutter or storm drain flow directly to the ocean.

Sediment is the most common pollutant washed from work sites, creating multiple problems once it enters the ocean. Sediment clogs the gills of fish, blocks light transmission and increases ocean water temperature, all of which both fish and people depend on.

Sediment also carries with it other work site pollutants such as pesticides, cleaning solvents, cement wash, asphalt and car fluids like motor oil, grease and fuel. Thus, poorly maintained vehicles and heavy equipment leaking fuel and oil on the construction site also contribute to ocean pollution.

As a Contractor, site supervisor, owner or operator of a site, you may be held responsible for the environmental damage caused by your Subcontractors or employees.

Solutions

Best Management Practices that include the proper handling, storage and disposal of materials can prevent pollutants from entering the storm drain system.

General Business Practices

- ✓ **Keep pollutants off exposed surfaces.** Place trash cans and recycling receptacles around the site.
- ✓ **Cover and maintain dumpsters.** Check frequently for leaks. Place dumpsters under a roof or cover with tarps or plastic sheeting. Never clean a dumpster by hosing it down on-site!
- ✓ **Keep materials out of the rain.** Cover exposed piles of soil or construction materials with plastic sheeting or temporary roofs.
- ✓ **Designate one area for auto parking,** vehicle refueling and routine equipment maintenance. The designated area should be well away from gutters or drains. Make all major repairs off-site.
- ✓ **Make sure portable toilets are in good working order.** Check frequently for leaks.
- ✓ **Use as little water as possible** for dust control.

Cleaning Up

1. **Clean up leaks, drips, and other spills immediately.** This will prevent contaminated soil or residue on paved surfaces.
2. **Never hose down "dirty" pavement or surfaces where materials have spilled.** Use dry cleanup methods whenever possible.

Advanced Planning to Prevent Pollution

An erosion control program, worked out before construction begins, prevents or minimizes most erosion and sedimentation problems.

- ❑ **Train your employees and Subcontractors.** Make these pamphlets available to everyone working on site. Inform Subcontractors about their own responsibilities.
- ❑ **Schedule excavation and grading activities** for dry weather periods.

- ❑ **Control surface runoff to reduce erosion,** especially during excavation. Use drainage ditches to divert water flow.

- ❑ **Prevent erosion by planting** fast - growing annual and perennial grasses. These will shield and bind the soil.

- ❑ **Do not remove trees or shrubs unnecessarily.** They help decrease erosion.

Handling Materials and Wastes

- **Practice Source Reduction** - minimize waste when ordering materials. Order only the amounts needed to complete the job.

- **Use recycled and recyclable materials** whenever possible.

- **Never bury waste materials** or leave them in the street.

- **Dispose of all waste properly.** Many construction materials, including solvents, water-based paints, vehicle fluids, broken asphalt and concrete, wood, and cleared vegetation can be recycled. Non-recyclable materials must be taken to an appropriate landfill or disposed of as hazardous waste. For disposal information, call the numbers listed in this pamphlet.

Disposal Options

Use a crushing company to recycle concrete, asphalt and porcelain rather than taking them to the landfill.
Call:

Recycling and Hazardous Waste Disposal:

Sun Street Transfer Station
Salinas Valley Solid Waste Authority
(831) 424-5520
139 Sun Street
Salinas, 93901

To Report a Spill, Illegal Dumping or a Clogged Storm Drain Call:

(831) 758-7233

City of Salinas

Department of Public Works Maintenance Division

For more information about storm drain protection or additional pamphlets, call:

(831) 758-7233

City of Salinas

Department of Public Works Maintenance Division

This is one in a series of pamphlets describing storm drain protection measures.

Other pamphlets include:

- Automotive Maintenance and Car Care**
- Equipment Rentals**
- Fresh Concrete and Mortar Application**
- Heavy Equipment and Earthmoving Activities**
- Landscaping, Gardening, and Pest Control**
- Mobile Washers and Cleaners**
- Roadwork and Paving**

CONTRACTORS: Save Time and \$ on Your Next Job...



Separate your Materials for Recycling!

REDUCE, REUSE & RECYCLE!

Ask the local waste hauler, Republic Services how to save by separating recyclables, or if self-hauling, bring the following source-separated materials to Sun St Transfer Station in the heart of Salinas for a discounted rate:

- ⇒ Yard waste
- ⇒ Wood waste
- ⇒ Mixed Construction and Demolition materials
- ⇒ Clean Concrete and asphalt (with or without rebar)*

For pricing and questions please call:

Republic Services: (831) 775-3840

Sun St Transfer Station: (831) 775-3000

Recycle Cardboard, Paper, Metal and Plastics for FREE!

**Larger clean loads (1 ton or greater) of concrete and asphalt must be taken to the Johnson Canyon Landfill, outside of Gonzales, call for more information.*



Sun Street Transfer Station

139 Sun St
Salinas, CA 93901

Phone: 831-775-3000

Fax: 831-755-1322

E-mail: mandyb@svswa.org



**Need help on your project?
Free technical assistance is
available, call (831) 775-3000**

For more information, visit :

www.salinasvalleyrecycles.org



"Working Toward a Future without Landfills"

PART F – TECHNICAL SPECIFICATIONS

ACCEPTABLE DEVICES

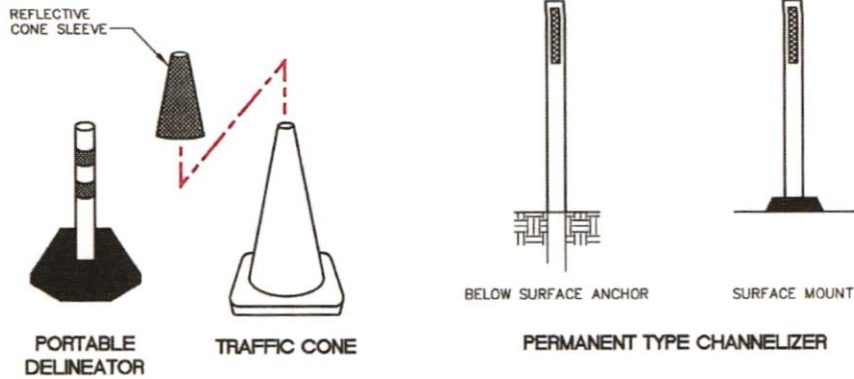

NOT ACCEPTABLE DEVICES

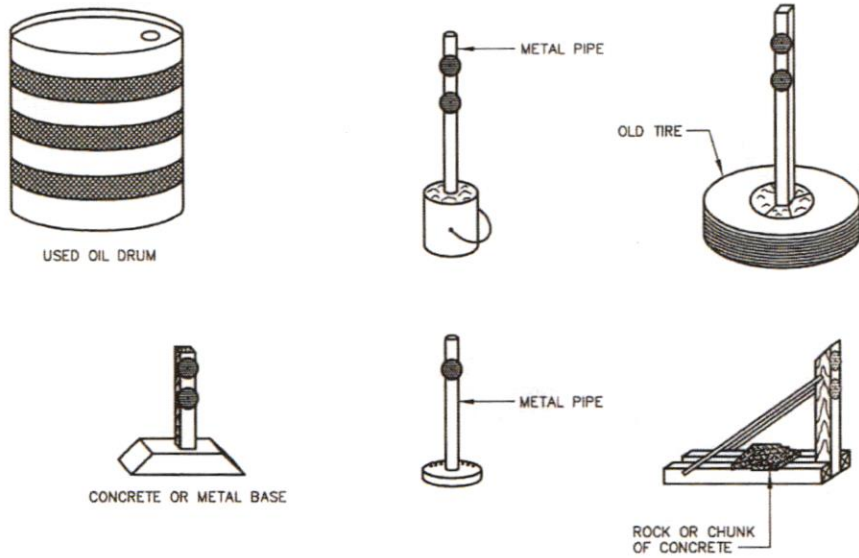

GENERAL NOTES

1. REFLECTORIZED MATERIAL FOR THE ACCEPTABLE DEVICES SHALL BE WHITE PER THE MOST CURRENT MANUAL ON UNIFORM TRAFFIC CONTROL DEVICE FOR STREETS AND HIGHWAYS.
2. DRAWING NOT TO SCALE.

DEVELOPMENT & ENGINEERING SERVICES DEPARTMENT		CITY OF SALINAS
ENGINEERING SERVICES DIVISION		
TITLE: CHANNELIZATION DEVICES		STANDARD PLAN
DESIGNED BY: STAFF	DATE: 10/21/2008	45
CADD BY: STAFF		
PROJECT MANAGER: FRANK A. AGUAYO, P.E.	ROBERT C. RUSSELL, CITY ENGINEER R.C.E. 42871, EXPIRES 3-31-2010	

WORK AREA TRAFFIC CONTROLS

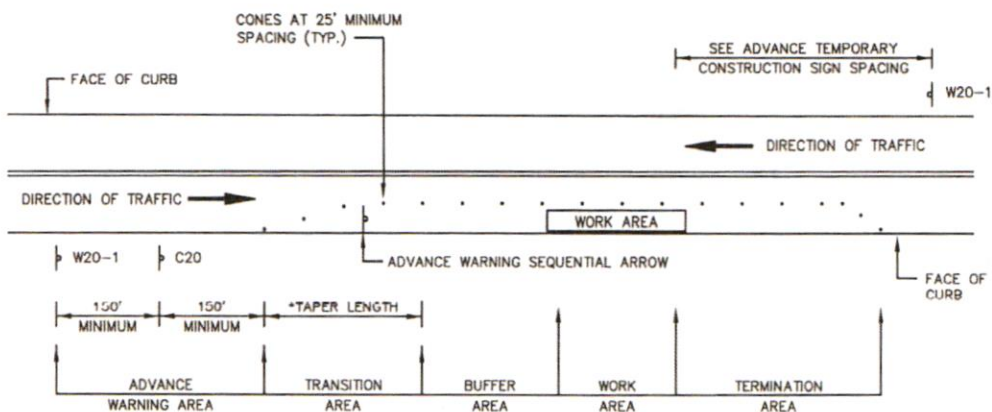

TEMPORARY
CONSTRUCTION
SIGN(S)

ADVANCE TEMPORARY
CONSTRUCTION SIGN SPACING

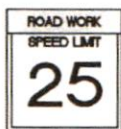
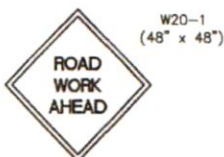

SPEED LIMIT
25 TO 35 MPH
40 MPH AND HIGHER

(ADVANCE OF TAPER AND
BETWEEN SIGNS)
100'
350'

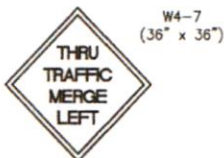

SPEED LIMIT
40 MPH OR LESS
45 MPH OR MORE

TRAFFIC CONE TAPER

TAPER LENGTH (L) FEET
 $L = ws^2 \div 60$
 $L = ws$

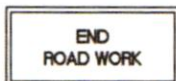
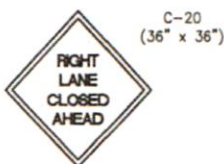

WHERE: L = TAPER LENGTH IN FEET
w = WIDTH OF OFFSET IN FEET
s = POSTED SPEED LIMIT, OR OFF-PEAK 85TH PERCENTILE SPEED PRIOR TO WORK STARTING, OR THE ANTICIPATED OPERATION SPEED IN MPH

GENERAL NOTES

- DRAWING NOT TO SCALE.

DEVELOPMENT & ENGINEERING SERVICES DEPARTMENT
ENGINEERING SERVICES DIVISION CITY OF SALINAS

TITLE: TYPICAL LANE CLOSURE		STANDARD PLAN <h1 style="font-size: 2em; margin: 0;">46</h1>
DESIGNED BY: STAFF CADD BY: STAFF PROJECT MANAGER: FRANK A. AGUAYO, P.E.	DATE <u>10/21/2008</u> ROBERT C. RUSSELL, CITY ENGINEER R.C.E. 42871, EXPIRES 3-31-2010 	

PART G- APPENDIX



Legend
 □ City of Salinas
 Boundary



MONTE BELLA MAINTENANCE DISTRICT ENTIRE SUBDIVISION MAP : See Site Description
 Section 9-1 (1-5)



9.028 0

The City of Salinas has made every reasonable effort to provide accurate and timely information. The City of Salinas does not, however, assume any responsibility, implied or otherwise, and makes no representations, warrant, or claim regarding the accuracy, omissions, or the reliance on second party data. Users are advised to seek independent verification before relying on this information.



WGS_1984_Web_Mercator_Auxiliary_Sphere
 THIS MAP IS NOT TO BE USED FOR NAVIGATION

Monte Bella Bioretention Area at Curb Bulb-Out

Campania Way	DMA 1-5
Sardinia Way	DMA 6 & 7
Sardinia Way & Bellagio	DMA 8 & 9
Bellagio Way, Palermo, Palermo Ct	DMA 10-15
Palermo Drive & Palermo Ct.	DMA 16-19
Palermo Drive & Marsala Way & Marsala Cir.	DMA 20-27
Palermo Drive & Napoli Cir. & Etna Cir.	DMA 28-33
Palermo Drive & Pisa Circle	DMA 34-39
Palermo Drive & Future	DMA 40-44
Future	DMA 45-48
Future	DMA 49 & 50
Rossano & Future	DMA 51-56

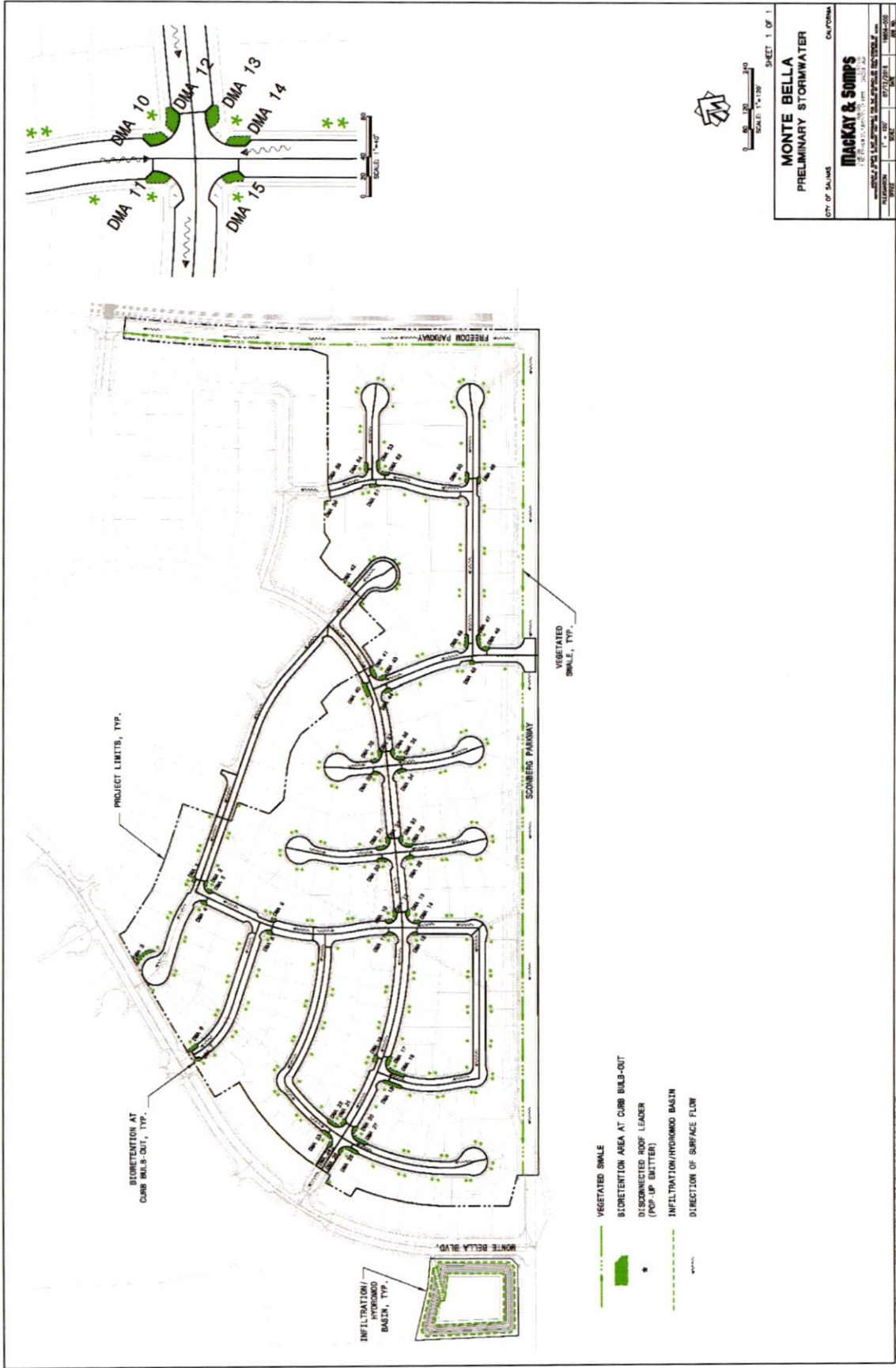



Monte Bella Retention Basin



Legend

City of Salinas Boundary

2018 Aerials

- Red: Band_1
- Green: Band 2
- Blue: Band_3



1:2,257



The City of Salinas has made every reasonable effort to provide accurate and timely information. The City of Salinas does not, however, assume any responsibility, implied or otherwise, and makes no representation, warrant, guarantee, or claim regarding accuracy, omissions, or the reliance on second party data. Users are advised to seek independent verification before relying on this information.

WGS_1984_Web_Mercator_Auxiliary_Sphere
THIS MAP IS NOT TO BE USED FOR NAVIGATION



(<https://www.dir.ca.gov/>)

State of California

Department of Industrial Relations

Contractor Information

Legal Entity Name
SMITH & ENRIGHT LANDSCAPING

Legal Entity Type
Corporation

Status
Active

Registration Number
1000011127

Registration effective date
07/01/21

Registration expiration date
06/30/23

Mailing Address

540 WORK ST SUITE C SALINAS 93901 CA United S...

Physical Address

540 WORK ST SUITE C SALINAS 93901 CA United S...

Email Address
selena@smithenright.com

Trade Name/DBA
SMITH & ENRIGHT LANDSCAPING, INC

License Number (s)
CSLB:757700

CSLB:757700

Registration History

Effective Date	Expiration Date
05/10/18	06/30/19
06/16/17	06/30/18
06/22/16	06/30/17
08/17/15	06/30/16
02/20/15	06/30/15
07/01/19	06/30/21
07/01/21	06/30/23

[Back to DIR>> \(https://www.dir.ca.gov/\)](https://www.dir.ca.gov/)

Legal Entity Information

Corporation Entity Number:

C2060437

Federal Employment Identification Number:

770468457

President Name:

JAMES SMITH

Vice President Name:
Treasurer Name:
Secretary Name:
CEO Name:

RICHARD ENRIGHT
RICHARD ENRIGHT
JAMES SMITH
JAMES SMITH

Agency for Service:
Agent of Service Name:
Agent of Service Mailing Address:

RICHARD ENRIGHT
540 WORK ST SUITE C SALINAS 93901 CA United States of America

Worker's Compensation

Do you lease employees through Professional Employer Organization (PEO)?: No

Please provide your current worker's compensation insurance information below:
PEO PEO PEO
PEO InformationName Phone Email

Insured by Carrier
Policy Holder Name: Smith & Enright Landscaping, Inc
Insurance Carrier: Service American Indemnity Co
Policy Number: SAAWC0000133-00
Inception date: 10/01/20
Expiration Date: 10/01/21

About DIR Work with Us Learn More
Who we are Jobs at DIR Acceso al idioma
(<https://www.dir.ca.gov/about/>) (<https://www.dir.ca.gov/dir/jobs/>) (<https://www.dir.ca.gov/idioma/>)
DIR Divisions, Boards Licensing, Services-
& Commissions registrations, Act/default.html
(https://www.dir.ca.gov/divisions_boards_and_commissions/)



State of California
Department of Industrial Relations

Contractor Information

Registration History

Legal Entity Name
Silvino Sanchez Landscaping

Effective Date	Expiration Date
03/15/21	06/30/21
07/01/21	06/30/22

Status

Active

Registration Number

[Back to DIR>> \(https://www.dir.ca.gov/\)](https://www.dir.ca.gov/)

PW-LR-1000726545

Registration effective date

07/01/21

Registration expiration date

06/30/22

Mailing Address

P.O. Box 1521 Carmel Valley 93924 CA United States of...

Physical Address

328 Roberts Ave. Seaside 93955 CA United States of A...

Email Address

cleanadmi@gmail.com

Trade Name/DBA

Silvino Sanchez Landscaping

License Number (s)

CSLB:1009392

Legal Entity Information

Federal Employment Identification Number:

614539631

Sole Proprietor Name:

Silvino Sanchez



State of California

Department of Industrial Relations

Contractor Information

Registration History

Legal Entity Name	HEMIT'S LANDSCAPING AND CONCRETE INC.	Effective Date	06/24/18	Expiration Date	06/30/19
Legal Entity Type	Corporation		07/12/17		06/30/18
Status	Active		04/23/15		06/30/15
Registration Number	1000020090		Back to DIR>> (https://www.dir.ca.gov/)		
Registration effective date	07/01/20		07/16/19		06/30/20
Registration expiration date	06/30/23		07/01/20		06/30/23
Mailing Address	446 Boronda Road SALINAS 93907 CA United State...				
Physical Address	446 Boronda Road SALINAS 93907 CA United State...				
Email Address	hemi0425@yahoo.com				
Trade Name/DBA					
License Number (s)	CSLB:903795				
	CSLB:903795				

Legal Entity Information

Corporation Entity Number:
Federal Employment Identification Number:
President Name:
Vice President Name:

C3766798
 ISIDRO HERNANDEZ
 MARISA HERNANDEZ

Treasurer Name:
Secretary Name:
CEO Name:

JUANA HERNANDEZ

Agency for Service:
Agent of Service Name:
Agent of Service Mailing Address:

MARTIN TRUJILLO
202 PAJARO ST SALINAS 93901 CA United States of America

Worker's Compensation

Do you lease employees through Professional Employer Organization (PEO)?: No
Please provide your current worker's compensation insurance information below:

PEO PEO PEO
PEO InformationName Phone Email

Insured by Carrier
Policy Holder Name: HEMI'S LANDSCAPING AND CONCRETE INC.
Insurance Carrier: Markel Insurance Company
Policy Number: MWC0153183-01
Inception date: 08/01/20
Expiration Date: 08/01/21

- About DIR
- Who we are
- DIR Divisions, Boards & Commissions
- Jobs at DIR
- Licensing, registrations, certifications & garnishments
- Work with Us
- Learn More
- Acceso al idioma
- Frequently Asked Questions

Contractor's License Detail for License # 757700

DISCLAIMER: A license status check provides information taken from the CSLB license database. Before relying on this information, you should be aware of the following limitations.

- ▶ CSLB complaint disclosure is restricted by law (B&P 7124.6) If this entity is subject to public complaint disclosure click on link that will appear below for more information. [Click here for a definition of disclosable actions.](#)
- ▶ Only construction related civil judgments reported to CSLB are disclosed (B&P 7071.17).
- ▶ Arbitrations are not listed unless the contractor fails to comply with the terms.
- ▶ Due to workload, there may be relevant information that has not yet been entered into the board's license database.

Data current as of 6/2/2021 3:28:10 PM

Business Information

SMITH AND ENRIGHT LANDSCAPING INC
540 WORK ST, SUITE C
SALINAS, CA 93901
Business Phone Number:(831) 758-6766

Entity Corporation
Issue Date 01/05/1999
Expire Date 01/31/2023

License Status

This license is current and active.

All information below should be reviewed.

Classifications

C27 - LANDSCAPING

Bonding Information

Contractor's Bond

This license filed a Contractor's Bond with OLD REPUBLIC SURETY COMPANY.

Bond Number: W150369413

Bond Amount: \$15,000

Effective Date: 02/21/2020

[Contractor's Bond History](#)

Bond of Qualifying Individual

The qualifying individual JAMES FRANKLAND SMITH certified that he/she owns 10 percent or more of the voting stock/membership interest of this company; therefore, the Bond of Qualifying Individual is not required.

Effective Date: 01/05/1999

Workers' Compensation

This license has workers compensation insurance with the SERVICE AMERICAN INDEMNITY COMPANY

Policy Number: SAAWC000013300

Effective Date: 10/01/2020

Expire Date: 10/01/2021

[Workers' Compensation History](#)

Contractor's License Detail for License # 1009392

DISCLAIMER: A license status check provides information taken from the CSLB license database. Before relying on this information, you should be aware of the following limitations.

- ▶ CSLB complaint disclosure is restricted by law (B&P 7124.6) If this entity is subject to public complaint disclosure click on link that will appear below for more information. Click here for a definition of disclosable actions.
- ▶ Only construction related civil judgments reported to CSLB are disclosed (B&P 7071.17).
- ▶ Arbitrations are not listed unless the contractor fails to comply with the terms.
- ▶ Due to workload, there may be relevant information that has not yet been entered into the board's license database.

Data current as of 6/2/2021 3:51:59 PM

Business Information

SILVINO SANCHEZ LANDSCAPING
PO BOX 143
SEASIDE, CA 93955
Business Phone Number:(831) 521-3782

Entity Sole Ownership
Issue Date 12/03/2015
Expire Date 12/31/2021

License Status

This license is current and active.

All information below should be reviewed.

Classifications

- ▶ C27 - LANDSCAPING
- ▶ C-61 / D49 - TREE SERVICE

Bonding Information

Contractor's Bond

This license filed a Contractor's Bond with BUSINESS ALLIANCE INSURANCE COMPANY.

Bond Number: G81009807280

Bond Amount: \$15,000

Effective Date: 11/11/2018

[Contractor's Bond History](#)

Workers' Compensation

This license has workers compensation insurance with the OHIO SECURITY INSURANCE COMPANY

Policy Number: XWS57238875

Effective Date: 02/15/2019

Expire Date: 02/15/2022

[Workers' Compensation History](#)

Contractor's License Detail for License # 903795

DISCLAIMER: A license status check provides information taken from the CSLB license database. Before relying on this information, you should be aware of the following limitations.

- ▶ CSLB complaint disclosure is restricted by law (B&P 7124.6) If this entity is subject to public complaint disclosure click on link that will appear below for more information. [Click here for a definition of disclosable actions.](#)
- ▶ Only construction related civil judgments reported to CSLB are disclosed (B&P 7071.17).
- ▶ Arbitrations are not listed unless the contractor fails to comply with the terms.
- ▶ Due to workload, there may be relevant information that has not yet been entered into the board's license database.

Data current as of 7/20/2021 12:39:51 PM

Business Information

HEMI'S LANDSCAPING AND CONCRETE INC
446 BORONDA RD
SALINAS, CA 93907
Business Phone Number:(831) 594-6182

Entity Corporation
Issue Date 09/21/2007
Reissue Date 07/31/2015
Expire Date 07/31/2023

License Status

This license is current and active.

All information below should be reviewed.

Classifications

- ▶ C-8 - CONCRETE
- ▶ C27 - LANDSCAPING

Bonding Information

Contractor's Bond

This license filed a Contractor's Bond with SURETEC INSURANCE COMPANY.

Bond Number: 130255
Bond Amount: \$15,000
Effective Date: 07/01/2020
[Contractor's Bond History](#)

Bond of Qualifying Individual

The qualifying individual ISIDRO HERNANDEZ-MURILLO certified that he/she owns 10 percent or more of the voting stock/membership interest of this company; therefore, the Bond of Qualifying Individual is not required.

Effective Date: 07/31/2015

Workers' Compensation

This license has workers compensation insurance with the PREFERRED PROFESSIONAL INSURANCE COMPANY

Policy Number: ON1016001
Effective Date: 08/01/2020
Expire Date: 08/01/2021
[Workers' Compensation History](#)



California Secretary of State
Electronic Filing



Corporation - Statement of Information No Change

Entity Name: SMITH & ENRIGHT LANDSCAPING, INC.

Entity (File) Number: C2060437

File Date: 09/09/2020

Entity Type: Corporation

Jurisdiction: CALIFORNIA

Document ID: GJ34667

There has been no change in any of the information contained in the previous complete Statement of Information filed with the California Secretary of State.

By signing this document, I certify that the information is true and correct and that I am authorized by California law to sign.

Electronic Signature: Selena Herrin

Use bizfile.sos.ca.gov for online filings, searches, business records, and resources.

Document ID: GJ34667



California Secretary of State
Electronic Filing



Corporation - Statement of Information

Entity Name: HEMI'S LANDSCAPING AND
CONCRETE INC.

Entity (File) Number: C3766798

File Date: 05/17/2021

Entity Type: Corporation

Jurisdiction: CALIFORNIA

Document ID: GT34455

Detailed Filing Information

1. Entity Name: HEMI'S LANDSCAPING AND
CONCRETE INC.

2. Business Addresses:
 - a. Street Address of Principal
Office in California: 446 Boronda Road
Salinas , California 93907
United States of America

 - b. Mailing Address: 446 Boronda Road
Salinas , California 93907
United States of America

 - c. Street Address of Principal
Executive Office: 446 Boronda Road
Salinas , California 93907
United States of America

3. Officers:
 - a. Chief Executive Officer: Isidro Hernandez
446 Boronda Road
Salinas , California 93907
United States of America

 - b. Secretary: Juana Hernandez
446 Boronda Road
Salinas , California 93907
United States of America

Use bizfile.sos.ca.gov for online filings, searches, business records, and resources.

Document ID: GT34455



California Secretary of State Electronic Filing

Officers (cont'd):

- c. Chief Financial Officer: Marisa Marie Hernandez
446 Boronda Road
Salinas , California 93907
United States of America
4. Director: Isidro Hernandez
446 Boronda Road
Salinas , California 93907
United States of America
- Number of Vacancies on the Board of Directors: 0
5. Agent for Service of Process: Marisa Marie Hernandez
446 Boronda Road
Salinas, California 93907
United States of America
6. Type of Business: Landscaping and Concrete

By signing this document, I certify that the information is true and correct and that I am authorized by California law to sign.

Electronic Signature: Isidro Hernandez

Use bizfile.sos.ca.gov for online filings, searches, business records, and resources.

Document ID: GT34455

City of Salinas

Business License



19 26 CONTRACTORS

License Section

30 Jun 2022

Expiration Date

**Smith & Enright Landscaping
540 WORK ST C
SALINAS, CA 93901**

Business Name and Address

License Number

07666

This license evidences that the person(s), firm, or corporation named herein has paid the applicable fee required by the Salinas City Code through the date indicated above. Under provisions of Chapter 19-3 of the Salinas City Code, issuance of this license shall not be construed as compliance with other City Ordinances, State Law, or Federal Laws.

DISPLAY IN A CONSPICUOUS PLACE

THIS LICENSE IS NOT TRANSFERABLE

Smith & Enright Landscaping

540 Work St #C
Salinas, CA 93901

Type of Business
Specialty Contractor

City of Salinas

Business License



19 26 CONTRACTORS

License Section

30 Jun 2022

Expiration Date

**Silvino Sanchez Landscaping
328 Roberts AVE
Seaside, CA 93955**

Business Name and Address

License Number

FINBL21-00148

This license evidences that the person(s), firm, or corporation named herein has paid the applicable fee required by the Salinas City Code through the date indicated above. Under provisions of Chapter 19-3 of the Salinas City Code, issuance of this license shall not be construed as compliance with other City Ordinances, State Law, or Federal Laws.

DISPLAY IN A CONSPICUOUS PLACE

THIS LICENSE IS NOT TRANSFERABLE

Silvino Sanchez Landscaping
Silvino Sanchez
PO BOX 143
Seaside, CA 93955

Type of Business
SPECIALTY CONTRACTOR

City of Salinas

Business License



19 26 CONTRACTORS

License Section

30 Jun 2022

Expiration Date

**Hemi's Landscaping & Concrete Inc
446 BORONDA RD (COUNTY)
SALINAS, CA 93907**

Business Name and Address

License Number

63684

This license evidences that the person(s), firm, or corporation named herein has paid the applicable fee required by the Salinas City Code through the date indicated above. Under provisions of Chapter 19-3 of the Salinas City Code, issuance of this license shall not be construed as compliance with other City Ordinances, State Law, or Federal Laws.

DISPLAY IN A CONSPICUOUS PLACE

THIS LICENSE IS NOT TRANSFERABLE

Hemi's Landscaping & Concrete Inc
Isidiro Hernandez
446 Boronda Rd
Salinas, CA 93907

Type of Business
Specialty Contractor

Great American Insurance Company

AMB #: 002213 NAIC #: 16691 FEIN #: 310501234

Domiciliary Address

301 E. Fourth Street
Cincinnati, Ohio 45202
United States

Web: www.greatamericaninsurancegroup.com

Phone: 513-369-5000

Fax: 513-369-3873

AM Best Rating Unit: AMB #: 005990 - Great American Insurance Companies

Assigned to insurance companies that have, in our opinion, a superior ability to meet their ongoing insurance obligations.



[View additional news, reports and products for this company.](#)

Based on AM Best's analysis, 058317 - American Financial Group, Inc. is the **AMB Ultimate Parent** and identifies the topmost entity of the corporate structure. [View a list of operating insurance entities in this structure.](#)

Best's Credit Ratings

Financial Strength View Definition

Rating (Rating Category): A+ (Superior)

Outlook (or Implication): Stable

Action: Affirmed

Effective Date: October 28, 2020

Initial Rating Date: September 30, 1908

Long-Term Issuer Credit View Definition

Rating (Rating Category): aa- (Superior)

Outlook (or Implication): Stable
Action: Affirmed
Effective Date: October 28, 2020
Initial Rating Date: June 17, 2005

Financial Size Category [View Definition](#)

Financial Size Category: XV (\$2 Billion or greater)

u Denotes Under Review Best's Rating

Best's Credit Rating Analyst

Rating Office: A.M. Best Rating Services, Inc.

Associate Director : Erik Miller

Director: Jennifer Marshall, CPCU, ARM

Note: See the Disclosure information Form or Press Release below for the office and analyst at the time of the rating event.

Disclosure Information

Disclosure Information Form

[View AM Best's Rating Disclosure Form](#)

Press Release

AM Best Affirms Credit Ratings of American Financial Group, Inc.; Upgrades Ratings of Key Life and Workers' Comp Entities
October 28, 2020

Rating History

AM Best has provided ratings & analysis on this company since 1908.

Financial Strength Rating

Effective Date	Rating
10/28/2020	A+
9/11/2019	A+

8/17/2018	A+
8/11/2017	A+
5/12/2016	A+

Long-Term Issuer Credit Rating

Effective Date	Rating
10/28/2020	aa-
9/11/2019	aa-
8/17/2018	aa-
8/11/2017	aa-
5/12/2016	aa-

Related Financial and Analytical Data

The following links provide access to related data records that AM Best utilizes to provide financial and analytical data on a consolidated or branch basis.

AMB #	Company Name	Company Description
005990	Great American Insurance Companies (SG) Rating Unit	Represents the AM Best Consolidated financials for the Property/Casualty business of this legal entity.
087045	Great American Insurance Company CAB	Represents the Property/Casualty financials for the Canada Branch of this legal entity.
094364	Great American Insurance Company (SGB)	Represents the Property/Casualty financials for the Singapore Branch of this legal entity.

Best's Credit & Financial Reports

 Best's Credit Report - financial data included in Best's Credit Report reflects the data used in determining the current credit rating(s) for AM Best Rating Unit: AMB #: 005990 - Great American Insurance Companies.

 Best's Credit Report - Archive - reports which were released prior to the current Best's Credit Report.

 Best's Financial Report - financial data included in Best's Financial Report reflects the most current data available to AM Best, including updated financial exhibits and additional company information, and is available to subscribers of Best's Insurance Reports.

View additional news, reports and products for this company.

Press Releases

<u>Date</u>	<u>Title</u>
Jan 28, 2021	AM Best Places Credit Ratings of American Financial Group's L/A Subs Under Review After Announced Sale; Comments on P/C Subs
Nov 19, 2020	AM Best Affirms Credit Ratings of El Águila, Compañía de Seguros, S.A. de C.V.
Oct 28, 2020	AM Best Affirms Credit Ratings of American Financial Group, Inc.; Upgrades Ratings of Key Life and Workers' Comp Entities
Nov 14, 2019	AM Best Affirms Credit Ratings of El Águila, Compañía de Seguros, S.A. de C.V.
Sep 11, 2019	AM Best Affirms Credit Ratings of American Financial Group, Inc. and Its Insurance Subsidiaries
Dec 14, 2018	AM Best Affirms Credit Ratings of El Águila, Compañía de Seguros, S.A. de C.V.

		1	2	3	4		
--	--	---	---	---	---	--	--

Page size: 10

33 items in 4 pages

Find a Best's Credit Rating

[Advanced Search](#)

**How to Get a
Best's Credit Rating**



**Best's Credit Ratings
Mobile App**



European Union Disclosures

A.M. Best (EU) Rating Services B.V. (AMB-EU), a subsidiary of A.M. Best Rating Services, Inc., is an External Credit Assessment Institution (ECAI) in the EU. Therefore, credit ratings issued and endorsed by AMB-EU may be used for regulatory purposes in the EU as per Directive 2013/36/EU.

United Kingdom Disclosures

A.M. Best – Europe Rating Services Limited (AMBERS), a subsidiary of A.M. Best Rating Services, Inc., is an External Credit Assessment Institution (ECAI) in the United Kingdom (UK). Therefore, Credit Ratings issued and endorsed by AMBERS may be used for regulatory purposes in the United Kingdom as per the Credit Rating Agencies (Amendment, etc.) (EU Exit) Regulations 2019.

Australian Disclosures

A.M. Best Asia-Pacific Limited (AMBAP), Australian Registered Body Number (ARBN No.150375287), is a limited liability company incorporated and domiciled in Hong Kong. AMBAP is a wholesale Australian Financial Services (AFS) Licence holder (AFS No. 411055) under the Corporations Act 2001. Credit ratings emanating from AMBAP are not intended for and must not be distributed to any person in Australia other than a wholesale client as defined in Chapter 7 of the Corporations Act. AMBAP does not authorize its Credit Ratings to be disseminated by a third-party in a manner that could reasonably be regarded as being intended to influence a retail client in making a decision in relation to a particular product or class of financial product. AMBAP Credit Ratings are intended for wholesale clients only, as defined.

Credit Ratings determined and disseminated by AMBAP are the opinion of AMBAP only and not any specific credit analyst. AMBAP Credit Ratings are statements of opinion and not statements of fact. They are not recommendations to buy, hold or sell any securities or any other form of financial product, including insurance policies and are not a recommendation to be used to make investment /purchasing decisions.

Important Notice: AM Best's Credit Ratings are independent and objective opinions, not statements of fact. AM Best is not an Investment Advisor, does not offer investment advice of any kind, nor does the company or its Ratings Analysts offer any form of structuring or financial advice. AM Best's credit opinions are not recommendations to buy, sell or hold securities, or to make any other investment decisions. For additional information regarding the use and limitations of credit rating opinions, as well as the rating process, information requirements and other rating related terms and definitions, please view Guide to Best's Credit Ratings.

[About Us](#) | [Careers](#) | [Contact](#) | [Events](#) | [Offices](#) | [Press Releases](#) | [Social Media](#) | [Legal & Licensing](#) | [Privacy](#) | [Site Map](#) | [Terms of Use](#)

[Regulatory Affairs](#) - [Form NRSRO](#) - [Code of Conduct](#) - [Rating Methodology](#) - [Historical Performance Data](#)

Copyright © 2021 A.M. Best Company, Inc. and/or its affiliates ALL RIGHTS RESERVED.

Service American Indemnity Company

AMB #: 020601 NAIC #: 39152 FEIN #: 592048400

Mailing Address

P.O. Box 26850
Austin, Texas 78755
United States

Web: www.servicelloyds.com

Phone: 512-637-3100

Fax: 512-485-2735

[View Additional Address Information](#)

AM Best Rating Unit: AMB #: 018385 - Service Insurance Group

Assigned to insurance companies that have, in our opinion, an excellent ability to meet their ongoing insurance obligations.



[View additional news, reports and products for this company.](#)

Based on AM Best's analysis, 046834 - Service Insurance Holdings, Inc. is the **AMB Ultimate Parent** and identifies the topmost entity of the corporate structure. [View a list of operating insurance entities in this structure.](#)

Best's Credit Ratings

Financial Strength View Definition

Rating (Rating Category): A- (Excellent)

Affiliation Code: p (Pooled)

Outlook (or Implication): Stable

Action: Affirmed

Effective Date: June 18, 2021

Initial Rating Date: July 05, 2018

Long-Term Issuer Credit View Definition

Rating (Rating Category): a- (Excellent)

Outlook (or Implication): Stable

Action: Affirmed

Effective Date: June 18, 2021

Initial Rating Date: July 05, 2018

Financial Size Category [View Definition](#)

Financial Size Category: VIII (\$100 Million to \$250 Million)

u Denotes Under Review Best's Rating

Best's Credit Rating Analyst

Rating Office: A.M. Best Rating Services, Inc.

Financial Analyst: Kourtnie Beckwith, CPCU, AU, AMIM

Associate Director : Daniel Teclaw

Note: See the Disclosure information Form or Press Release below for the office and analyst at the time of the rating event.

Disclosure Information

Disclosure Information Form

[View AM Best's Rating Disclosure Form](#)

[View AM Best's Rating Review Form](#)

Rating History

AM Best has provided ratings & analysis on this company since 2018.

Financial Strength Rating

Effective Date	Rating
6/18/2021	A-
7/30/2020	A-
8/15/2019	A-
7/5/2018	A-

3/23/2018

NR

Long-Term Issuer Credit Rating

Effective Date	Rating
6/18/2021	a-
7/30/2020	a-
8/15/2019	a-
7/5/2018	a-
3/23/2018	nr

Best's Credit & Financial Reports

 Best's Credit Report - financial data included in Best's Credit Report reflects the data used in determining the current credit rating(s) for AM Best Rating Unit: AMB #: 018385 - Service Insurance Group.

 Best's Credit Report - Archive - reports which were released prior to the current Best's Credit Report.

 Best's Financial Report - financial data included in Best's Financial Report reflects the most current data available to AM Best, including updated financial exhibits and additional company information, and is available to subscribers of Best's Insurance Reports.

View additional news, reports and products for this company.

Press Releases

<u>Date</u>	<u>Title</u>
Jul 05, 2018	A.M. Best Assigns Credit Ratings to Service American Indemnity Company

Find a Best's Credit Rating

[Advanced Search](#)

**How to Get a
Best's Credit Rating**



**Best's Credit Ratings
Mobile App**



European Union Disclosures

A.M. Best (EU) Rating Services B.V. (AMB-EU), a subsidiary of A.M. Best Rating Services, Inc., is an External Credit Assessment Institution (ECAI) in the EU. Therefore, credit ratings issued and endorsed by AMB-EU may be used for regulatory purposes in the EU as per Directive 2013/36/EU.

United Kingdom Disclosures

A.M. Best – Europe Rating Services Limited (AMBERS), a subsidiary of A.M. Best Rating Services, Inc., is an External Credit Assessment Institution (ECAI) in the United Kingdom (UK). Therefore, Credit Ratings issued and endorsed by AMBERS may be used for regulatory purposes in the United Kingdom as per the Credit Rating Agencies (Amendment, etc.) (EU Exit) Regulations 2019.

Australian Disclosures

A.M. Best Asia-Pacific Limited (AMBAP), Australian Registered Body Number (ARBN No.150375287), is a limited liability company incorporated and domiciled in Hong Kong. AMBAP is a wholesale Australian Financial Services (AFS) Licence holder (AFS No. 411055) under the Corporations Act 2001. Credit ratings emanating from AMBAP are not intended for and must not be distributed to any person in Australia other than a wholesale client as defined in Chapter 7 of the Corporations Act. AMBAP does not authorize its

Credit Ratings to be disseminated by a third-party in a manner that could reasonably be regarded as being intended to influence a retail client in making a decision in relation to a particular product or class of financial product. AMBAP Credit Ratings are intended for wholesale clients only, as defined.

Credit Ratings determined and disseminated by AMBAP are the opinion of AMBAP only and not any specific credit analyst. AMBAP Credit Ratings are statements of opinion and not statements of fact. They are not recommendations to buy, hold or sell any securities or any other form of financial product, including insurance policies and are not a recommendation to be used to make investment /purchasing decisions.

Important Notice: AM Best's Credit Ratings are independent and objective opinions, not statements of fact. AM Best is not an Investment Advisor, does not offer investment advice of any kind, nor does the company or its Ratings Analysts offer any form of structuring or financial advice. AM Best's credit opinions are not recommendations to buy, sell or hold securities, or to make any other investment decisions. For additional information regarding the use and limitations of credit rating opinions, as well as the rating process, information requirements and other rating related terms and definitions, please view Guide to Best's Credit Ratings.

[About Us](#) | [Careers](#) | [Contact](#) | [Events](#) | [Offices](#) | [Press Releases](#) | [Social Media](#) | [Legal & Licensing](#) | [Privacy](#) | [Site Map](#) | [Terms of Use](#)

[Regulatory Affairs](#) - [Form NRSRO](#) - [Code of Conduct](#) - [Rating Methodology](#) - [Historical Performance Data](#)

Copyright © 2021 A.M. Best Company, Inc. and/or its affiliates ALL RIGHTS RESERVED.