

TYPE A

TYPE B

TYPE C

INTEGRAL CURB AND GUTTER

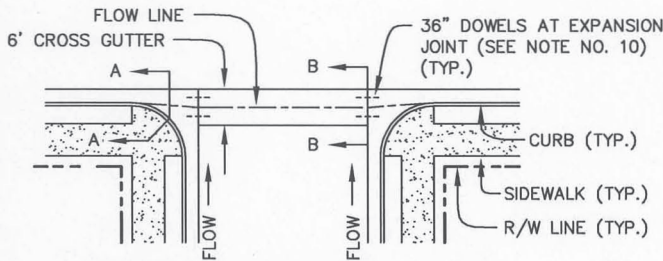

TYPICAL CROSS GUTTER DETAIL

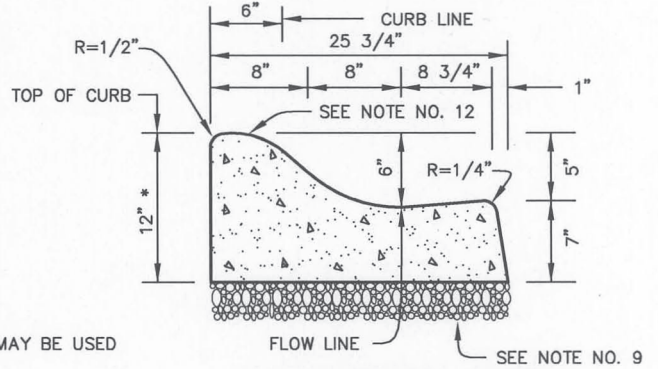

STANDARD ROLL CURB

GENERAL NOTES

* NOMINAL DIMENSION BACK-FORM MAY BE USED EXCEPT IN INDUSTRIAL AREAS

- DRAWING NOT TO SCALE.
- ALL WORK SHALL BE DONE IN ACCORDANCE WITH SECTION 73 OF THE CITY STANDARD SPECIFICATIONS.
- EXPANSION JOINTS SHALL BE SLIP DOWELED AT CURB RETURNS (SEE CITY STANDARD PLAN NO. 2).
- TOP AND FRONT OF ALL CURBS SHALL BE FINE BROOM FINISHED.
- CURB RETURNS SHALL BE TYPE "C" EXCEPT ADJACENT TO CROSS GUTTERS, WHERE MODIFIED TYPE "C" CURB AND APRON SHALL BE USED.
- CURB AND GUTTER AT COMMERCIAL DRIVEWAYS SHALL HAVE 2 #4 BARS INSTALLED FOR THE WIDTH OF THE DRIVEWAY (HEAVY DUTY TYPE "C" CURB AND GUTTER).
- INSTALL 3/8" EXPANSION JOINTS AT 20' INTERVALS MAX. ON TYPE "C" CURB. PROVIDE WEAKENED PLANE JOINTS AT 10' INTERVALS WITH EXPANSION AT 60' INTERVALS ON EXTRUDED CURB (SEE CITY STANDARD PLAN NO. 2).
- CLASS "3" CONCRETE PER CITY STANDARD SPECIFICATIONS SHALL BE USED.
- 6" MINIMUM CLASS 2 A.B. OR HIGHER TYPE SHALL BE USED FOR BASE MATERIALS.
- CROSS GUTTERS SHALL HAVE TWO #4 x 36" LONG STEEL DOWELS AT MID-DEPTH CENTERED AT EXPANSION JOINT. FOR SLIP DOWEL DETAIL SEE CITY STANDARD PLAN NO. 2.
- AN ADHESIVE APPROVED BY THE CITY ENGINEER MAY BE USED IN LIEU OF DOWELS IN TYPE "A" EXTRUDED CURB FOR PLACEMENT ON EXISTING PAVEMENT. OMIT HORIZONTAL STEEL IN EXTRUDED CURB (EXCEPT ACROSS COMMERCIAL DRIVEWAYS).
- CONTRACTOR SHALL STAMP TOP OF CURB WITH THE LETTERS "G" (GAS), "S" (SEWER), AND/OR "W" (WATER) TO IDENTIFY UTILITY SERVICE LOCATIONS.
- WITHIN INDUSTRIAL AREAS SUBJECT TO HEAVY TRUCK TRAFFIC, THE CONCRETE THICKNESS SHALL BE a=14", b=8", AND c=9 1/4".

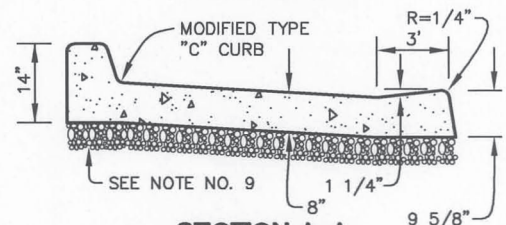
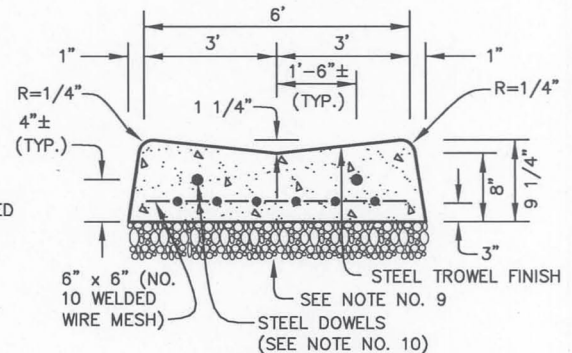

DEVELOPMENT & ENGINEERING SERVICES DEPARTMENT

ENGINEERING SERVICES DIVISION

CITY OF SALINAS

TITLE: **CURBS AND GUTTERS**

STANDARD PLAN

DESIGNED BY:
STAFF

DATE 10/21/2008

CADD BY:
STAFF

Robert C. Russell

PROJECT MANAGER:
FRANK A. AGUAYO, P.E.

ROBERT C. RUSSELL, CITY ENGINEER
R.C.E. 42871, EXPIRES 3-31-2010



1

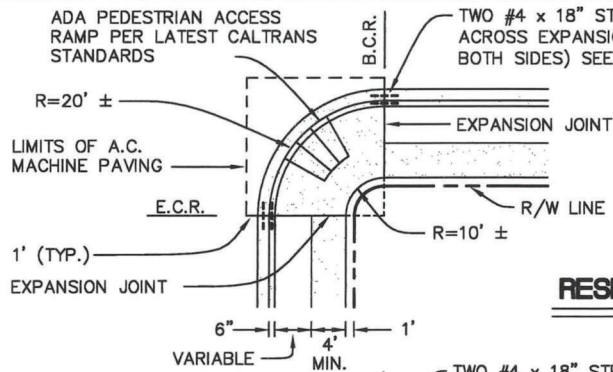

RESIDENTIAL STANDARDS

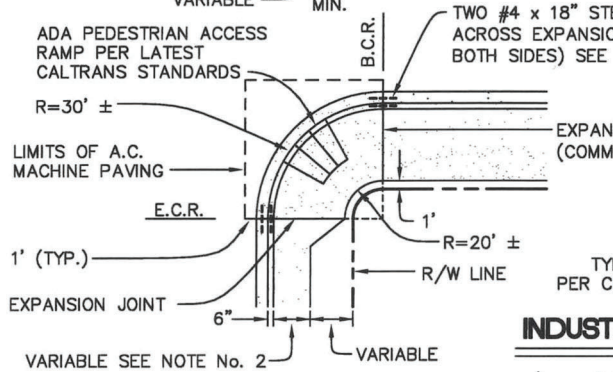
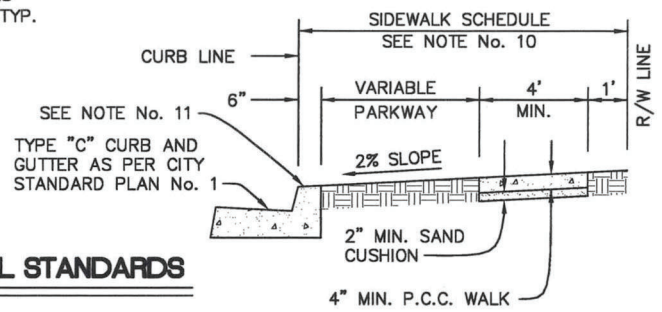

INDUSTRIAL-COMMERCIAL STANDARDS

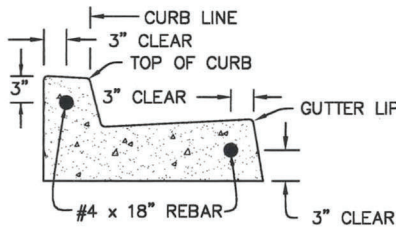
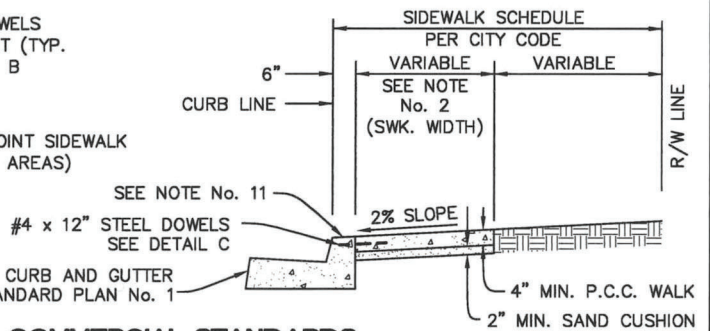

DETAIL 'B'

TYPICAL DOWEL DETAIL AT CURB RETURNS

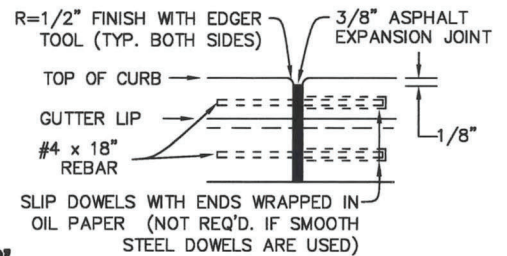

DETAIL 'A'

TYPICAL SIDEWALK EXPANSION JOINT

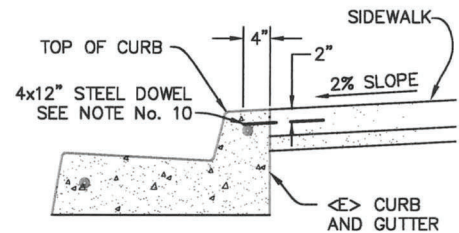
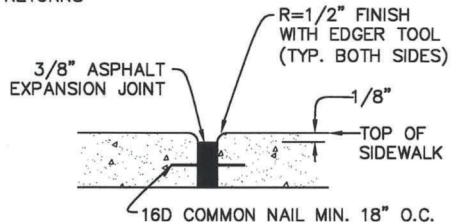

DETAIL 'C'

TYPICAL DOWEL DETAIL AT CURB/SIDEWALK

GENERAL NOTES

- DRAWING NOT TO SCALE.
- CONCRETE SIDEWALK SHALL BE 8.5' MINIMUM IN COMMERCIAL AREAS AND 5.5' MINIMUM FOR INDUSTRIAL AREAS. A 6' SIDEWALK CAN BE USED IN COMMERCIAL AREAS UPON APPROVAL OF THE CITY ENGINEER. ALL SIDEWALKS SHALL HAVE A MINIMUM 4' CLEAR PASSAGE, FREE OF OBSTRUCTIONS AND/OR HINDRANCES, AS OUTLINED IN TITLE 24 OF THE CALIFORNIA BUILDING CODE.
- ALL SIDEWALKS SHALL BE ONE COURSE, CLASS "3" P.C.C. WITH A FINE BROOM FINISH.
- ASPHALT EXPANSION JOINTS SHALL BE PLACED WITH MAXIMUM SPACING OF 60' AND WHEREVER SIDEWALK ADJOINS EXISTING BUILDING OR SIDEWALK. SCORE LINES SHALL BE PROVIDED FOR EVERY 16 TO 22 S.F. AT 4' INTERVALS AND PROPORTIONAL OR AS DIRECTED BY THE CITY ENGINEER.
- ASPHALT EXPANSION JOINT SHALL BE COMPOSED OF ASPHALT, FIBER, AND MINERAL FILLER PREMOLDED INTO SHEETS WITH ASPHALT IMPREGNATED LINERS ON BOTH SIDES AND SHALL CONFORM WITH ASTM 1751 AND AASHTO M-33-48 SPECIFICATIONS.
- REBAR SHALL BE INSTALLED PER DETAIL "B" AT B.C.R. AND E.C.R.
- CONTRACTOR SHALL STAMP HIS/HER NAME, MONTH, AND YEAR OF CONSTRUCTION ON SIDEWALK, WITH A MINIMUM OF ONCE PER CONSTRUCTION AND ONCE PER EACH 500 S.F., MONTH AND YEAR MAY BE STAMPED IN NUMBERS.
- ALL DIMENSIONS AS SHOWN UNLESS OTHERWISE SPECIFIED ON PLANS.
- ADA PEDESTRIAN ACCESS RAMP SHALL BE PER LATEST CALTRANS STANDARDS.
- SIDEWALKS LOCATED ADJACENT TO CURB, SHALL HAVE DOWELS BETWEEN CURB AND SIDEWALK REQUIRED AT 12' ON CENTER.
- CONTRACTOR SHALL STAMP TOP OF CURB WITH THE LETTERS "G" (GAS), "S" (SEWER), AND/OR "W" (WATER) TO IDENTIFY UTILITY LOCATIONS.

PUBLIC WORKS DEPARTMENT

ENGINEERING SERVICES DIVISION

CITY OF SALINAS

TITLE: SIDEWALKS AND CURB RETURNS

STANDARD PLAN

DESIGNED BY:
STAFF

CADD BY:
STAFF

PROJECT MANAGER:
EDA HERRERA P.E.

DATE 2/3/2017

Francisco A. Aguayo

FRANCISCO A. AGUAYO,
CITY ENGINEER, R.C.E. 59378

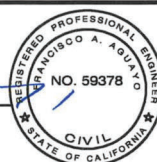

2R

RESIDENTIAL DRIVEWAY APPROACH

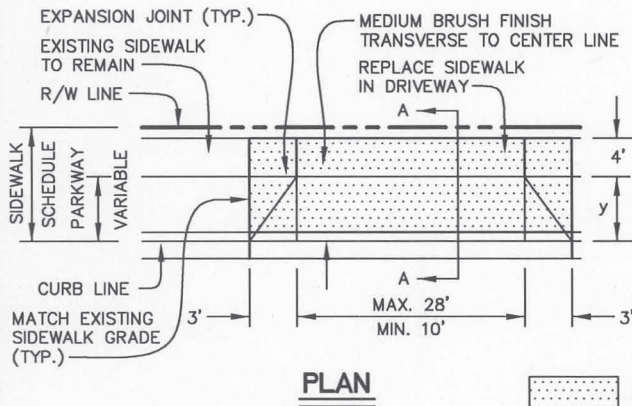

PLAN



DRIVEWAY APPROACH LIMITS

COMMERCIAL DRIVEWAY APPROACH

OPTION: 4' SIDEWALK MAY BE BEHIND PROPERTY LINE

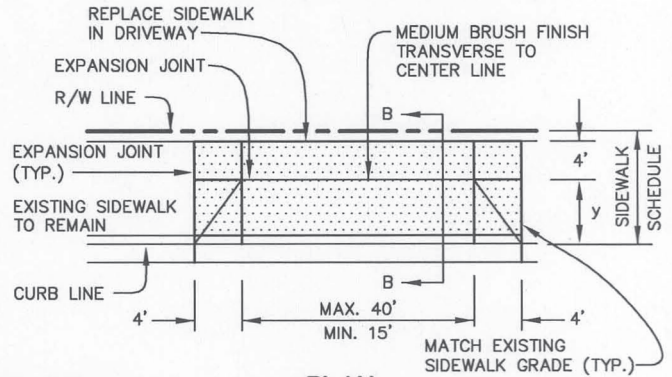

PLAN

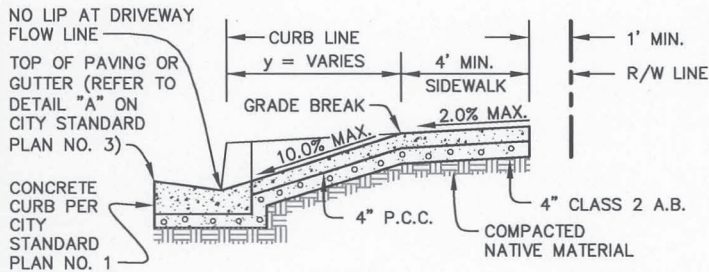

SECTION A-A

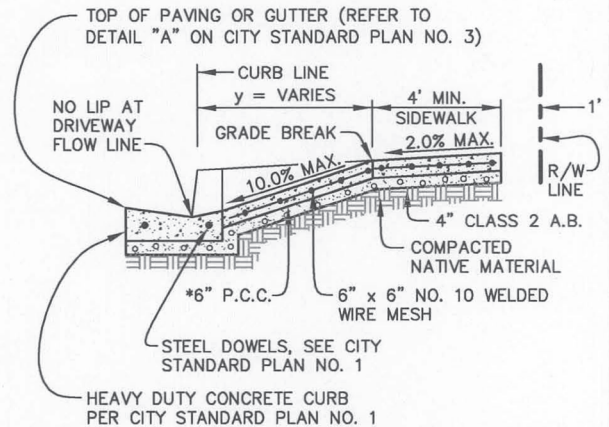

SECTION B-B

GENERAL NOTES

- DRAWING NOT TO SCALE.
- ALL WORK SHALL BE CONSTRUCTED IN ACCORDANCE WITH THE LATEST ADOPTED CITY STANDARD SPECIFICATIONS.
- THE AREA INCLUDED WITHIN THE "y" SLOPES SHALL BE MEDIUM BRUSH FINISH. THE BALANCE OF THE DRIVEWAY SHALL BE FINE BROOM FINISH TO MATCH THE ADJOINING SIDEWALK. SCORING LINES SHALL BE SPACED TO EVENLY DIVIDE THE AREA INTO BLOCKS OF NOT LESS THAN 3' AND NOT MORE THAN 4' OR MATCH EXISTING.
- RESIDENTIAL DRIVEWAYS SHALL HAVE 4" MINIMUM CLASS 4 A.B. (OR BETTER). COMMERCIAL DRIVEWAYS SHALL HAVE 4" MINIMUM CLASS 2 A.B. AND 6" x 6" NO. 10 WELDED WIRE MESH PLACED AT MID-DEPTH OF CONCRETE.
- CONCRETE SHALL BE CLASS "3" PER CITY STANDARD SPECIFICATIONS.
- ON RESIDENTIAL DRIVEWAY CONSTRUCTION ONLY, CONTRACTOR MAY REMOVE VERTICAL CURB AND CONSTRUCT DRIVEWAY AGAINST REMAINING GUTTER. CITY ENGINEER APPROVED BONDING AGENT OR EPOXY SHALL BE APPLIED TO JOIN CONCRETE SURFACES.
- CURB HEIGHT HIGHER THAN 6 1/2" SHALL BE APPROVED BY THE CITY ENGINEER PRIOR TO CONSTRUCTION.
- * INCREASE CONCRETE THICKNESS BY 2" FOR DRIVEWAYS SERVING INDUSTRIAL SITES WHICH ARE SUBJECT TO HEAVY TRUCK TRAFFIC.
- ALL DRIVEWAYS SHALL INCLUDE SIDEWALKS THAT ARE ADA COMPLIANT.

DEVELOPMENT & ENGINEERING SERVICES DEPARTMENT

ENGINEERING SERVICES DIVISION

CITY OF SALINAS

TITLE: **DRIVEWAY APPROACH**

STANDARD PLAN

DESIGNED BY:
STAFF

DATE 10/21/2008

CADD BY:
STAFF

PROJECT MANAGER:
FRANK A. AGUAYO, P.E.

ROBERT C. RUSSELL, CITY ENGINEER
R.C.E. 42871, EXPIRES 3-31-2010



5

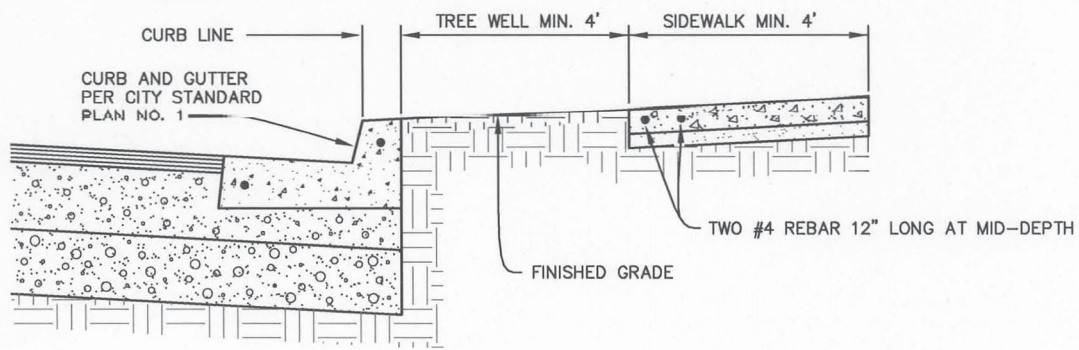
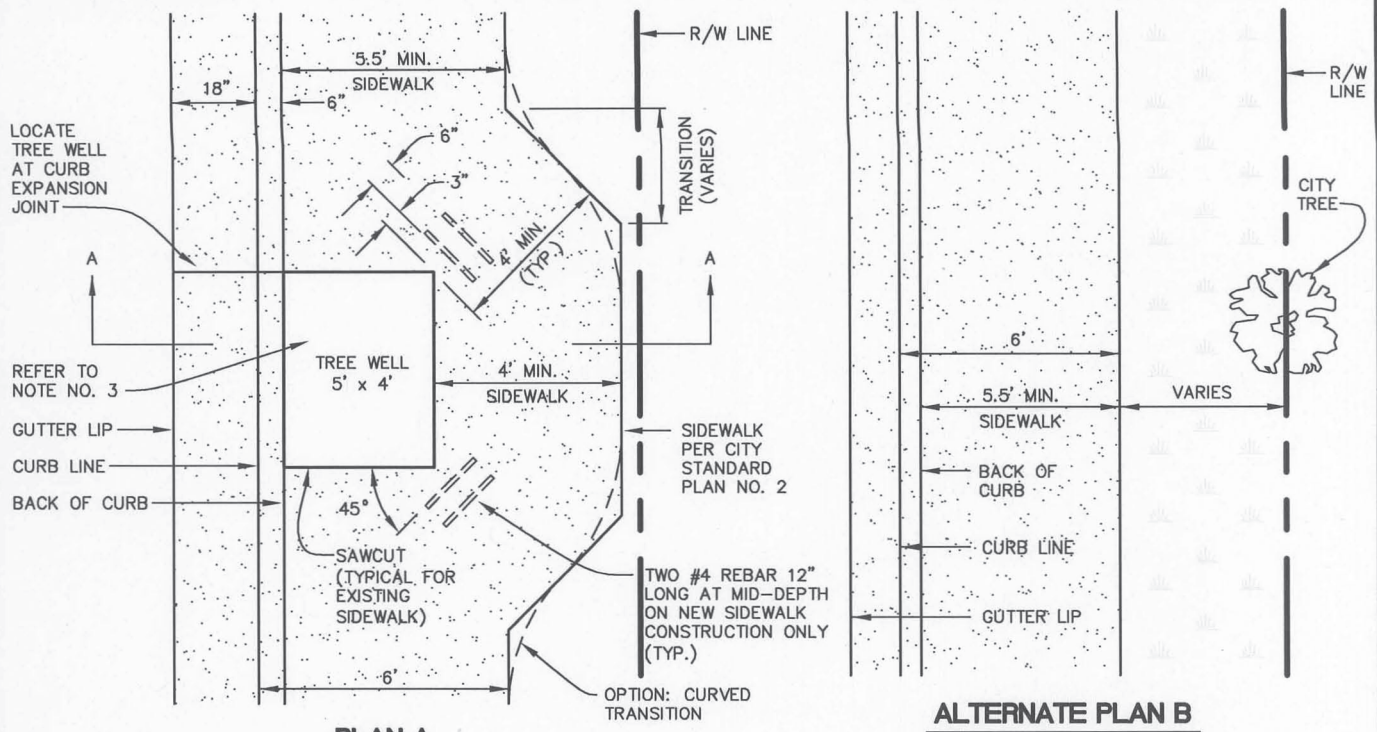

GENERAL NOTES

1. DRAWING NOT TO SCALE.
2. FOR STREET TREE PLANTING SEE CITY STANDARD PLAN NO. 11.
3. TREE WELL SHALL BE 5' x 4' MINIMUM RECTANGLE.
4. UNLESS OTHERWISE SPECIFIED IN THE SPECIFICATIONS AND/OR PLANS ALL PLACEMENT OF TREE WELL LOCATIONS SHALL BE AS FOLLOWS:
 - a. MINIMUM OF 40' FROM THE POINT OF INTERSECTION OF CURB LINE (P.I.).
 - b. MINIMUM OF 40' FROM THE TRAFFIC SIGNAL POLES.
 - c. MINIMUM OF 15' FROM COMMERCIAL DRIVEWAYS AND 10' FROM RESIDENTIAL DRIVEWAYS.
 - d. MINIMUM OF 25' FROM CATCH BASINS, SANITARY SEWER MAINS AND LATERALS, AND MANHOLES.
 - e. MINIMUM OF 5' FROM WATER METERS, WATER LINES, GAS LINES, STORM DRAIN LINES, AND UNDERGROUND ELECTRICAL LINES.
 - f. MINIMUM OF 10' FROM FIRE HYDRANTS.
 - g. MINIMUM OF 20' FROM STREET LIGHT POLES.
 - h. MINIMUM OF 10' FROM UTILITY POLES.
 - i. MINIMUM OF 40' TO 80' OF SPACING BETWEEN TREES (AVERAGE SPACING IS 60' APART) OR ONE TREE PER LOT. SPECIES OF TREE AND SPACING SHALL BE DETERMINED BY CITY ENGINEER.

DEVELOPMENT & ENGINEERING SERVICES DEPARTMENT
 ENGINEERING SERVICES DIVISION CITY OF SALINAS

TITLE: TREE WELL	
DESIGNED BY: STAFF	DATE <u>10/21/2008</u>
CADD BY: STAFF	
PROJECT MANAGER: FRANK A. AGUAYO, P.E.	ROBERT C. RUSSELL, CITY ENGINEER R.C.E. 42871, EXPIRES 3-31-2010

STANDARD PLAN

10

