



# City of Salinas, California



## **STANDARD SPECIFICATIONS DESIGN STANDARDS AND STANDARD PLANS**

**2008 EDITION**

**ISSUED BY:  
DEVELOPMENT & ENGINEERING SERVICES  
DEPARTMENT**



**CITY OF SALINAS, CALIFORNIA**

**PART I STANDARD SPECIFICATIONS**

**PART II DESIGN STANDARDS**

**PART III STANDARD PLANS**

**2008 EDITION**

*ISSUED BY:*

**DEVELOPMENT AND ENGINEERING SERVICES  
DEPARTMENT**

COPIES OF THIS BOOK MAY BE PURCHASED AT THE COUNTER FOR \$43.00 (TAX INCLUDED) PER EACH AND \$53.00 FOR MAIL ORDER (TAX, SHIPPING AND HANDLING INCLUDED) PER EACH, SEND ORDER AND REMITTANCE TO:

CITY OF SALINAS  
DEVELOPMENT AND ENGINEERING SERVICES DEPARTMENT  
200 LINCOLN AVENUE  
SALINAS, CA 93901

ALSO COPIES CAN BE DOWNLOADED AT  
<http://www.ci.salinas.ca.us/services/engineering/pdf/2008CityStandards.pdf>  
WITHOUT CHARGE.





# PART I

## STANDARD SPECIFICATIONS

### TABLE OF CONTENTS

#### GENERAL PROVISIONS

<i>Section No.</i>	<i>Title Description</i>	<i>Page No.</i>
<b>1.</b>	<b>Definitions and Terms .....</b>	<b>Pg. 1-3</b>
1-1.02	Abbreviations .....	Pg. 1
1-1.10	Contractor .....	Pg. 1-2
1-1.18	Engineer.....	Pg. 2
1-1.19	Engineer’s Estimate.....	Pg. 2
1-1.25	Laboratory .....	Pg. 2
1-1.255	Legal Holidays .....	Pg. 2
1-1.37	Special Provisions .....	Pg. 2
1-1.49	Right-of-Way.....	Pg. 2
1-1.50	Attorney General .....	Pg. 2
1-1.51	State Highway Engineer.....	Pg. 2
1-1.52	Local Public Agency .....	Pg. 2
1-1.53	Owner .....	Pg. 2
1-1.54	Provide.....	Pg. 2
1-1.55	Site.....	Pg. 2
1-1.56	City of Salinas or City.....	Pg. 2-3
<b>2.</b>	<b>Proposal Requirements and Conditions .....</b>	<b>Pg. 3-5</b>
2-1.01	Contents of Proposal Forms .....	Pg. 3
2-1.03	Examination of Plans, Specifications, Contract and Site of Work.....	Pg. 3-4
2-1.05	Proposal Forms.....	Pg. 4
2-1.07	Proposal Guaranty .....	Pg. 4
2-1.08	Withdrawal of Proposals .....	Pg. 4
2-1.09	Compliance with Local Hiring for Public Works .....	Pg. 4-5
2-1.12	Material Guaranty.....	Pg. 5
<b>3.</b>	<b>Award and Execution of Contract.....</b>	<b>Pg. 5-6</b>
3-1.02	Contract Bonds .....	Pg. 5
3-1.03	Execution of Contract.....	Pg. 6
3-1.04	Failure to Execute Contract.....	Pg. 6
<b>4.</b>	<b>Scope of Work .....</b>	<b>Pg. 6</b>
4-1.03	Changes .....	Pg. 6
4-1.04	Detours .....	Pg. 6
<b>5.</b>	<b>Control of Work .....</b>	<b>Pg. 6-9</b>
5-1.01	Authority of the City Engineer .....	Pg. 7
5-1.02B	Open Trench Excavations Deeper Than 4 Feet Below the Surface.....	Pg. 7

TABLE OF CONTENTS (PART I STANDARD SPECIFICATIONS) – Continued

5-1.04	Coordination and Interpretation of Plans, Standard Specifications, and Special Provisions .....	Pg. 7-8
5-1.06	Superintendence .....	Pg. 8
5-1.07	Lines and Grades .....	Pg. 8
5-1.08	Inspection .....	Pg. 9
5-1.09	Work Done by Others.....	Pg. 9
<b>6.</b>	<b>Control of Materials.....</b>	<b>Pg. 9-10</b>
6-3.02	Testing by Contractor.....	Pg. 9-10
<b>7.</b>	<b>Legal Relations and Responsibility.....</b>	<b>Pg. 10-13</b>
7-1.01A(3)	Payroll Records.....	Pg. 10
7-1.01F	Air Pollution Control.....	Pg. 10
7-1.01G	Water Pollution.....	Pg. 10-11
7-1.01I	Sound Control Requirements .....	Pg. 11
7-1.04	Permits and Licenses .....	Pg. 11
7-1.08	Public Convenience.....	Pg. 11
7-1.09	Public Safety.....	Pg. 11-12
7-1.09A	Street Closures.....	Pg. 12
7-1.12	Responsibility for Damage.....	Pg. 12-13
7-1.15	Relief from Maintenance and Responsibility .....	Pg. 13
<b>8.</b>	<b>Prosecution and Progress .....</b>	<b>Pg. 13-18</b>
8-1.01	Subcontracting.....	Pg. 13-14
8-1.03	Beginning of Work.....	Pg. 14
8-1.04	Progress Schedule.....	Pg. 14
8-1.041	Schedule Review .....	Pg. 14
8-1.06	Time of Completion .....	Pg. 14
8-1.08	Termination of Control.....	Pg. 14-15
8-1.10	Utility and Non-Highway Facilities .....	Pg. 15-18
<b>9.</b>	<b>Measurement and Payment.....</b>	<b>Pg. 18-21</b>
9-1.01	Measurement and Quantities .....	Pg. 18-19
9-1.02	Scope of Payment.....	Pg. 19
9-1.06	Partial Payments.....	Pg. 19-20
9-1.061	Beneficial Use .....	Pg. 20
9-1.065	Payment of Withheld Funds .....	Pg. 20
9-1.07B	Final Payment and Claims.....	Pg. 20-21
9-1.07C	Satisfaction of Liens.....	Pg. 21
9-1.08	Adjustment of Overhead Costs.....	Pg. 21

MISCELLANEOUS

<b>10.</b>	<b>Dust Control.....</b>	<b>Pg. 21-22</b>
10-1.03	Cleanup.....	Pg. 21
10-1.04	Payment .....	Pg. 22
<b>11.</b>	<b>Mobilization .....</b>	<b>Pg. 22</b>

TABLE OF CONTENTS (PART I STANDARD SPECIFICATIONS) – Continued

<b>12.</b>	<b>Construction Area Traffic Control Devices .....</b>	<b>Pg. 22</b>
12-2.02	Flagging Costs.....	Pg. 22
12-3.03	Flashing Arrow Signs.....	Pg. 22
12-3.08	Temporary Railing (Type K).....	Pg. 22
12-3.12	Portable Changeable Message Signs.....	Pg. 22
12-4.	Measurement and Payment .....	Pg. 22
<b>13. through 14. (Blanks) .....</b>		<b>Pg. 22</b>
<b>15.</b>	<b>Existing Highway Facilities .....</b>	<b>Pg. 22-23</b>
15-2.02A	Obliterating Roads and Detours .....	Pg. 23
15-2.05A	Frames, Covers, Grates, and Manholes.....	Pg. 23
15-2.07	Payment .....	Pg. 23
15-3.02	Concrete Removal Methods .....	Pg. 23
15-3.04	Removing Concrete Payment.....	Pg. 23

GRADING

<b>16.</b>	<b>Clearing and Grubbing.....</b>	<b>Pg. 23</b>
<b>17.</b>	<b>Watering.....</b>	<b>Pg. 23</b>
17-1.04	Payment .....	Pg. 24
<b>18.</b>	<b>Dust Palliative .....</b>	<b>Pg. 24</b>
18-1.05	Payment .....	Pg. 24
<b>19.</b>	<b>Earthwork .....</b>	<b>Pg. 24-35</b>
19-1.03	Grade Tolerance .....	Pg. 24
19-2.01A	Preparation of Subgrade .....	Pg. 24-25
19-2.06	Surplus Material .....	Pg. 25
19-3.	Structure Excavation and Backfill.....	Pg. 25
19-3.06	Structure Backfill .....	Pg. 25-26
19-3.062	Slurry Cement Backfill.....	Pg. 26
19-4.	Open Trench Operations .....	Pg. 26
19-4.01	Trench Excavation.....	Pg. 26-27
19-4.011	Maximum and Minimum Width of Trench.....	Pg. 27
19-4.012	Access to Trenches .....	Pg. 27
19-4.013	Removal and Replacement of Surface Improvements .....	Pg. 27
19-4.014	Bracing Excavations.....	Pg. 27-28
19-4.015	Bedding .....	Pg. 28-29
19-4.016	Pipe Laying.....	Pg. 29-30
19-4.02	Trenching in Improved Areas.....	Pg. 30
19-4.021	Trench Excavation.....	Pg. 30-31
19-4.022	Trench Backfill.....	Pg. 31-32
19-4.022A	Backfill Material.....	Pg. 32
19-4.022B	Backfill for Cast-In-Place Concrete Pipe .....	Pg. 32
19-4.023	Trench Requirements .....	Pg. 32-33
19-4.03	Trenches in Unimproved Areas.....	Pg. 33
19-4.031	Trench Excavation.....	Pg. 33

TABLE OF CONTENTS (PART I STANDARD SPECIFICATIONS) – Continued

19-4.032	Trench Backfill.....	Pg. 33-34
19-4.032A	Backfill for Cast-In-Place Concrete Pipe.....	Pg. 34
19-4.04	Subdivision and Unimproved Streets.....	Pg. 34
19-4.041	Trench Excavation.....	Pg. 34
19-4.042	Trench Backfill.....	Pg. 34
19-4.05	Payment.....	Pg. 34
19-4.06	Ditch Excavation.....	Pg. 35
19-4.061	Measurement.....	Pg. 35
19-4.062	Payment.....	Pg. 35
<b>20.</b>	<b>Landscape and Irrigation .....</b>	<b>Pg. 35-59</b>
20-1.	General.....	Pg. 35-36
20-2.	Landscape Materials.....	Pg. 36
20-2.01	Topsoil.....	Pg. 36
20-2.011	Class “A” Topsoil.....	Pg. 36
20-2.011a	Gradation Limits.....	Pg. 36
20-2.011b	Permeability Rate.....	Pg. 36
20-2.011c	Agricultural Suitability.....	Pg. 36
20-2.012	Class “B” Topsoil.....	Pg. 37
20-2.013	Class “C” Topsoil.....	Pg. 37
20-2.02	Soil Fertilizing and Conditioning Materials.....	Pg. 37
20-2.021	Commercial Fertilizer.....	Pg. 37
20-2.022	Organic Soil Amendment.....	Pg. 37-38
20-2.023	Mulch.....	Pg. 38
20-2.03	Seed.....	Pg. 38
20-2.04	Plants.....	Pg. 38-39
20-2.041	Trees.....	Pg. 39
20-2.042	Shrubs.....	Pg. 39
20-2.043	Prostrate Growing Plants.....	Pg. 39
20-2.044	Sod and Stolons (turf grass).....	Pg. 39
20-2.045	Cuttings.....	Pg. 39
20-2.05	Headers, Stakes, and Ties.....	Pg. 39
20-2.051	Headers and Stakes.....	Pg. 40
20-2.052	Tree Stakes.....	Pg. 40
20-3.	Irrigation System Materials.....	Pg. 40
20-3.01	Pipe and Fittings.....	Pg. 40
20-3.011	Steel Pipe.....	Pg. 40
20-3.012	Plastic Pipe for use with Solvent Weld Socket or Threaded Fittings.....	Pg. 40-41
20-3.013	Plastic Pipe for use with Rubber Ring Gaskets.....	Pg. 41
20-3.014	Copper Pipe.....	Pg. 41
20-3.02	Valves and Valve Boxes.....	Pg. 41
20-3.021	Gate and Ball Valves.....	Pg. 41
20-3.022	Manual Control Valves.....	Pg. 41
20-3.023	Remote Control Valves.....	Pg. 41-42
20-3.024	Garden Valves.....	Pg. 42
20-3.025	Quick-Coupling Valves and Assemblies.....	Pg. 42
20-3.025A	Master Valve and a flow meter in all irrigation systems.....	Pg. 42
20-3.026	Valve Boxes.....	Pg. 42

TABLE OF CONTENTS (PART I STANDARD SPECIFICATIONS) – Continued

20-3.03	Backflow Preventer Assembly .....	Pg. 42-43
20-3.04	Sprinkler Equipment.....	Pg. 43-44
20-3.05	Electrical Materials.....	Pg. 44
20-3.051	Conduit .....	Pg. 44
20-3.052	Conductors.....	Pg. 44
20-3.053	Controller Unit .....	Pg. 44
20-3.054	Pullboxes .....	Pg. 44
20-4.	Landscape and Irrigation Installation .....	Pg. 44-45
20-4.01	Earthwork and Topsoil Placement .....	Pg. 45
20-4.02	Trench Excavation and Backfill .....	Pg. 45
20-4.03	Topsoil Preparation and Conditioning .....	Pg. 45
20-4.031	Fertilizing and Conditioning Procedures.....	Pg. 46
20-4.032	Finished Grading .....	Pg. 46
20-4.04	Header Installation .....	Pg. 46
20-4.05	Planting.....	Pg. 46
20-4.051	Protection and Storage.....	Pg. 46
20-4.052	Layout and Plant Location .....	Pg. 46-47
20-4.053	Specimen Planting.....	Pg. 47
20-4.054	Tree and Shrub Planting .....	Pg. 47
20-4.06	Plant Staking and Guying.....	Pg. 48
20-4.061	Tree Staking .....	Pg. 48
20-4.062	Guying.....	Pg. 48
20-4.07	Ground Cover and Vine Planting .....	Pg. 48
20-4.08	Lawn Planting.....	Pg. 48
20-4.081	Seed Lawn Planting.....	Pg. 48-49
20-4.082	Sod Lawn Planting .....	Pg. 49
20-4.083	Stolon Planting .....	Pg. 49-50
20-4.09	Erosion Control Planting.....	Pg. 50
20-4.091	Straw Stabilization .....	Pg. 50
20-4.092	Seeding and Mulching.....	Pg. 50
20-4.10	Sprigging .....	Pg. 50-51
20-4.11	Watering .....	Pg. 51
20-5.	Irrigation System Installation .....	Pg. 51
20-5.01	Irrigation Pipeline Installation.....	Pg. 51-52
20-5.011	Steel Pipeline.....	Pg. 52
20-5.012	Plastic Pipeline .....	Pg. 52-53
20-5.013	Copper Pipeline .....	Pg. 53
20-5.02	Installation of Valves, Valve Boxes, and Special Equipments .....	Pg. 53-54
20-5.03	Sprinkler Head Installation and Adjustment .....	Pg. 54
20-5.031	Location, Elevation and Spacing.....	Pg. 54
20-5.032	Riser and Nozzle Line Installation .....	Pg. 54-55
20-5.033	Sprinkler Head Adjustment.....	Pg. 55
20-5.04	Automatic Control System Installation .....	Pg. 55-56
20-5.05	Flushing and Testing .....	Pg. 56-57
20-6.	Plant Establishment Work.....	Pg. 57-59
20-7.	Guarantee.....	Pg. 59
20-8.	Measurement and Payment .....	Pg. 59
<b>21.</b>	<b>(Blank) .....</b>	<b>Pg. 59</b>



TABLE OF CONTENTS (PART I STANDARD SPECIFICATIONS) – Continued

**22. Finishing Roadway .....Pg. 59**  
**23. (Blank) .....Pg. 60**

SUBBASES AND BASES

**24. Lime Treatment .....Pg. 60**  
**25. Aggregate Subbases.....Pg. 60-61**  
25-1.02D Class 6, Class 7, and Class 8 Aggregate Subbases.....Pg. 60  
25-1.06 Measurement .....Pg. 60-61  
25-1.07 Payment .....Pg. 61  
**26. Aggregate Bases .....Pg. 61-62**  
26-1.01 Description .....Pg. 61  
25-1.02C Class 4 Aggregate Base.....Pg. 61-62  
26-1.04 Spreading.....Pg. 62  
26-1.05 Compacting .....Pg. 62  
26-1.07 Payment .....Pg. 62  
**27. Cement Treated Bases.....Pg. 62**  
**28. Lean Concrete Base.....Pg. 62**  
**29. Treated Permeable Bases.....Pg. 63**  
**30. through 36. (Blanks) .....Pg. 63**

SURFACING AND PAVEMENTS

**37. Bituminous Seals.....Pg. 63**  
37-1.04 Preparation for Seal Coat .....Pg. 63  
37-1.05 Applying Asphaltic Emulsion .....Pg. 63  
37-1.07 Finishing.....Pg. 63  
37-1.09 Payment .....Pg. 63  
**38. (Blank) .....Pg. 63**  
**39. Asphalt Concrete .....Pg. 64-66**  
39-4.02 Prime Coat and Paint Binder (Tack Coat).....Pg. 64  
39-6.01 General Requirements .....Pg. 64-65  
39-6.03 Compacting .....Pg. 65  
39-8.02 Payment .....Pg. 66  
**40. Portland Cement Concrete Pavement .....Pg. 66**  
**41. Pavement Subsealing.....Pg. 66**

TABLE OF CONTENTS (PART I STANDARD SPECIFICATIONS) – Continued

**42. Groove and Grind Pavement.....Pg. 65**  
**43. through 48. (Blanks) .....Pg. 66**

STRUCTURES

**49. Piling.....Pg. 66**  
**50. Prestressing Concrete.....Pg. 66**  
**51. Concrete Structures .....Pg. 66-67**  
 51-1.12C Premolded Expansion Joint Fillers .....Pg. 67  
**52. Reinforcement.....Pg. 67**  
**53. Shotcrete.....Pg. 67**  
 53-1.01 Description .....Pg. 67  
**54. Waterproofing .....Pg. 67**  
**55. Steel Structures.....Pg. 67**  
**56. Signs.....Pg. 68**  
 56-2.01 Description .....Pg. 68  
**57. Timber Structures .....Pg. 68**  
**58. Preservative Treatment of Lumber, Timber, and Piling.....Pg. 68**  
**59. Painting.....Pg. 68**  
**60. (Blank) .....Pg. 68**

DRAINAGE AND SEWER FACILITIES

**61. Culvert and Drainage Pipe Joints.....Pg. 68**  
**62. Alternative Culverts .....Pg. 68**  
**63. Cast-In-Place.....Pg. 68-71**  
 63-1.05 Construction .....Pg. 69-70  
 63-1.06 Curing.....Pg. 70  
 63-1.07 Reinforced Cast-In-Place Pipe .....Pg. 70  
 63-1.08 Measurement .....Pg. 70-71  
 63-1.09 Payment .....Pg. 71  
**64. Plastic Pipe .....Pg. 71**  
 64-1.01 Description .....Pg. 71

TABLE OF CONTENTS (PART I STANDARD SPECIFICATIONS) – Continued

<b>65.</b>	<b>Reinforced Concrete Pipe .....</b>	<b>Pg. 71</b>
65-1.10	Payment .....	Pg. 71
<b>66.</b>	<b>Corrugated Metal Pipe .....</b>	<b>Pg. 71</b>
<b>67.</b>	<b>Structural Steel Plate Pipe.....</b>	<b>Pg. 71</b>
<b>68.</b>	<b>Subsurface Drains .....</b>	<b>Pg. 72</b>
<b>69.</b>	<b>Overside Drains .....</b>	<b>Pg. 72</b>
<b>70.</b>	<b>Miscellaneous Facilities.....</b>	<b>Pg. 72</b>
<b>71.</b>	<b>Sewers.....</b>	<b>Pg. 72-106</b>
71-1.	Description .....	Pg. 72
71-2.	Materials .....	Pg. 72
71-2.01	Vitrified Clay Sewer Pipe.....	Pg. 72-73
71-2.011	Blisters .....	Pg. 73
71-2.012	Cracks .....	Pg. 73
71-2.013	Chips.....	Pg. 73
71-2.014	Repairable Imperfections .....	Pg. 73-74
71-2.015	Fittings and Stoppers .....	Pg. 74
71-2.016	Joints.....	Pg. 74-75
71-2.017	Clay Pipe Repair.....	Pg. 75-76
71-2.018	Installation and Field Inspection .....	Pg. 76
71-2.02	Acrylonitrile-Butadiene-Styrene (ABS) Solid Wall Pipe .....	Pg. 76-77
71-2.021	Chemical Resistance (Pickle Jar Test) .....	Pg. 77-78
71-2.022	Pipe Acceptance .....	Pg. 78
71-2.023	Marking .....	Pg. 78
71-2.024	Installation and Field Inspection .....	Pg. 79
71-2.025	Installation Time Limit.....	Pg. 79
71-2.03	ABS or PVC Composite Pipe.....	Pg. 79
71-2.031	Material Composition and Testing .....	Pg. 79
71-2.032	Chemical and Physical Testing .....	Pg. 79
71-2.033	Pipe Acceptance .....	Pg. 79
71-2.034	Marking .....	Pg. 79
71-2.035	Repair .....	Pg. 79-80
71-2.036	Installation and Field Inspection .....	Pg. 80
71-2.04	PVC Plastic Pipe .....	Pg. 80
71-2.041	Manufacturer Identification Marks .....	Pg. 80
71-2.042	Cell Classification .....	Pg. 80
71-2.043	Joining Systems.....	Pg. 80-81
71-2.044	Test Requirements.....	Pg. 81-82
71-2.05	Annular High Density Polyethylene Pipe with Smooth Interior, Corrugated Exterior, with Bell-and-Spigot Joints.....	Pg. 82
71-2.051	Specification for HDPE Profile Wall Pipe .....	Pg. 82-83
71-2.052	Reworked Material .....	Pg. 83
71-2.053	Installation and Field Inspection .....	Pg. 83
71-2.06	Polyethylene (PE) Solid Wall Pipe .....	Pg. 83

TABLE OF CONTENTS (PART I STANDARD SPECIFICATIONS) – Continued

71-2.061	Material Composition.....	Pg. 83-84
71-2.062	Pipe Acceptance .....	Pg. 84
71-2.063	Chemical Resistance and Physical Testing .....	Pg. 84-85
71-2.064	Installation and field Inspection .....	Pg. 85
71-2.07	Ductile Iron Pipe (DIP) and Fittings .....	Pg. 85
71-2.08	Miscellaneous Iron and Steel .....	Pg. 85
71-2.09	Manholes .....	Pg. 85-86
71-2.10	Guide Specification for HDPE Manholes .....	Pg. 86
71-2.101	General .....	Pg. 86
71-2.102	Materials .....	Pg. 86-87
71-2.103	Manufacturer’s Quality Control .....	Pg. 87
71-2.104	Requirements.....	Pg. 87
71-2.105	Inspection and Testing.....	Pg. 88
71-2.106	Installation.....	Pg. 88
71-2.107	Delivery.....	Pg. 89
71-2.11	Pipe Laying.....	Pg. 89
71-2.12	Trench Resurfacing .....	Pg. 89
71-3.	Testing of Sewers .....	Pg. 89
71-3.01	Mandrel Testing of Plastic Pipe and Fittings .....	Pg. 90-92
71-3.02	Air Pressure Testing .....	Pg. 92-93
71-3.02(A)	Air Tables.....	Pg. 93-104
71-3.03	Television Inspection .....	Pg. 104-105
71-4.	Measurement .....	Pg. 105
71-5.	Payment .....	Pg. 106
<b>72.</b>	<b>Slope Protection .....</b>	<b>Pg. 106</b>
<b>73.</b>	<b>Concrete Curbs and Sidewalks .....</b>	<b>Pg. 106-111</b>
73-1.01	Description .....	Pg. 106
73-1.02	Subgrade Preparation .....	Pg. 107
73-1.03	Existing Curbs, Gutters, Driveways, and Sidewalks.....	Pg. 107
73-1.04	Forms.....	Pg. 107
73-1.05	Curb Construction .....	Pg. 107-108
73-1.051	Extruded or Slip-Formed Curb Construction .....	Pg. 108-110
73-1.052	Drainage Outlets Through Curb.....	Pg. 110
73-1.06	Sidewalk, Gutter Depression, Island Paving, ADA Pedestrian Access Ramp, and Driveway Construction.....	Pg. 110-111
73-1.07	Measurement .....	Pg. 111
73-1.08	Payment .....	Pg. 111
<b>74.</b>	<b>Pumping Plant Equipment .....</b>	<b>Pg. 111</b>
<b>75.</b>	<b>Miscellaneous Metal .....</b>	<b>Pg. 111</b>
<b>76. through 79.</b>	<b>(Blanks) .....</b>	<b>Pg. 111</b>
RIGHT-OF-WAY AND TRAFFIC CONTROL FACILITIES		
<b>80.</b>	<b>Fences .....</b>	<b>Pg. 112</b>

TABLE OF CONTENTS (PART I STANDARD SPECIFICATIONS) – Continued

<b>81.</b>	<b>Monuments.....</b>	<b>Pg. 112</b>
81-1.01	Description .....	Pg. 112
81-1.03	Construction .....	Pg. 112
81-1.04	Installation .....	Pg. 112
81-1.05	Measurement .....	Pg. 112
81-1.06	Payment .....	Pg. 112
<b>82.</b>	<b>Markers and Delineators .....</b>	<b>Pg. 113</b>
<b>83.</b>	<b>Railing and Barriers.....</b>	<b>Pg. 113</b>
<b>84.</b>	<b>Traffic Stripes and Pavement Markings .....</b>	<b>Pg. 113-120</b>
84-1.02	Control of Alignment and Layout .....	Pg. 113
84-1.03	Tolerances and Appearance.....	Pg. 113
84-2.02	Materials .....	Pg. 114
84-2.021	Characteristics .....	Pg. 114-115
84-2.022	Packaging .....	Pg. 115-116
84-2.03	Testing .....	Pg. 116
84-2.04	Application .....	Pg. 116-118
84-2.041	Traffic Control.....	Pg. 118
84-2.042	Application Equipment.....	Pg. 118-119
84-2.043	Curb Painting.....	Pg. 119
84-2.044	Alignment.....	Pg. 119
84-2.045	Changes in the Work .....	Pg. 119
84-2.046	Correction of Work .....	Pg. 119
84-2.047	Warranty .....	Pg. 120
84-2.048	Thermoplastic Removals.....	Pg. 120
84-2.06	Payment .....	Pg. 120
<b>85.</b>	<b>Pavement Markers .....</b>	<b>Pg. 121</b>
85-1.06	Placement .....	Pg. 121
85-1.09	Payment .....	Pg. 121

<b>86.</b>	<b>Signals and Lighting.....</b>	<b>Pg. 121</b>
------------	----------------------------------	----------------

<b>87.</b>	<b>(Blank) .....</b>	<b>Pg. 121</b>
------------	----------------------	----------------

MATERIALS

<b>88.</b>	<b>Engineering Fabrics .....</b>	<b>Pg. 121</b>
------------	----------------------------------	----------------

<b>89.</b>	<b>Lightweight Portland Cement Concrete .....</b>	<b>Pg. 121</b>
------------	---	----------------

<b>90.</b>	<b>Portland Cement Concrete .....</b>	<b>Pg. 121-122</b>
------------	---------------------------------------	--------------------

90-1.01	Description .....	Pg. 122
---------	-------------------	---------

<b>91.</b>	<b>Paint.....</b>	<b>Pg. 122</b>
------------	-------------------	----------------

TABLE OF CONTENTS (PART I STANDARD SPECIFICATIONS) – Continued

<b>92.</b>	<b>Asphalts .....</b>	<b>Pg. 122</b>
<b>93.</b>	<b>Liquid Asphalts.....</b>	<b>Pg. 122</b>
<b>94.</b>	<b>Asphaltic Emulsions .....</b>	<b>Pg. 122</b>
<b>95.</b>	<b>Epoxy .....</b>	<b>Pg. 123</b>



# PART II

## DESIGN STANDARDS

### TABLE OF CONTENTS

#### GENERAL PROVISIONS

<i>Section No.</i>	<i>Title Description</i>	<i>Page No.</i>
<b>I.</b>	<b>Improvement Policy for Subdivisions and Unimproved Streets .....</b>	<b>Pg. 127-130</b>
	A. General .....	Pg. 127
	B. Roadway Paving.....	Pg. 127
	C. Curbs .....	Pg. 127
	D. Sidewalks .....	Pg. 127-128
	E. Driveways.....	Pg. 128
	F. Street Lighting.....	Pg. 128
	G. Monuments.....	Pg. 128-129
	H. Street Signs.....	Pg. 129
	I. Storm Drains .....	Pg. 129
	J. Sanitary Sewers.....	Pg. 129-130
	K. Fire Protection.....	Pg. 130
	L. Right-Of-Ways and Easements .....	Pg. 130
	M. Parking and Traffic Circulation.....	Pg. 130
<b>II.</b>	<b>Storm Drain Design .....</b>	<b>Pg. 131</b>
<b>III.</b>	<b>Sanitary Sewer Design.....</b>	<b>Pg. 131-132</b>
	A. Design.....	Pg. 131
	B. Depth of Sewers .....	Pg. 131-132
	C. Connections to Sewers .....	Pg. 132
<b>IV.</b>	<b>Development Plan Check List.....</b>	<b>Pg. 133-134</b>
	1. Site Plans .....	Pg. 133
	A. General Requirements.....	Pg. 133
	B. Legal/Mapping Requirements.....	Pg. 133
	2. Construction Plans.....	Pg. 133
	A. Concrete Work .....	Pg. 133
	B. Drainage/Grading Plan.....	Pg. 134
	C. Sanitary Sewer Plan .....	Pg. 134
<b>V.</b>	<b>City of Salinas – Subdivision Processing Checklist .....</b>	<b>Pg. 135-136</b>
	1. Initial Submittal.....	Pg. 135
	2. Subsequent Submittal.....	Pg. 136
	3. Final Submittal .....	Pg. 136

**TABLE OF APPENDICES**

**APPENDIX - A**

<b>Development Plans</b> .....	<b>Pg. 137-161</b>
A. General .....	Pg. 137
B. Standards To Control Excavation, Cuts, Fills, Clearing, Grading, Erosion and Sediment.....	Pg. 137-161

# PART III

## STANDARD PLANS

### TABLE OF CONTENTS

<i>Standard Plan No.</i>	<i>Title Description</i>
1	Curbs and Gutters
2R	Sidewalk and Curb Returns ( <i>Updated 3-7-17</i> )
3	Street Structural Sections
4A	Type "A" and Type "B" ADA Pedestrian Access Ramps
4B	Type "C" and Type "D" ADA Pedestrian Access Ramps
5	Driveway Approach
6	Driveway Approach for Roll Type Curb
7	Alley Approach and Section
8	City Monument
9	Benchmark for Elevation Control
10	Tree Well
11	Street Tree Planting
12	Raised Median Island Standard Construction Plan
13	Raised Median Island Standard Planting Plan
14	Median Island Details
15	Pork Chop Island and Reflective Marker
16	Trench Backfill and Surface Restoration
17	Cast-In-Place Concrete Pipe
18	Miscellaneous Storm Drain Details
19	Curb Drain
20	Storm Drain Marker Installation
21	Type "A" Catch Basin
22	Type "D" Side Opening Catch Basin
23	Type "E" Top Opening Catch Basin
24	Type "F" Catch Basin
25	Type "A" and "B" Manhole
26	Type "C" Manhole (Shallow Type)
27	Manhole Frame and Cover
28	Manhole Frame and Cover Adjustment
29	Sewer Saddle Connection
30	Flushing Inlet Frame and Cover
31	Flushing Inlet
32	Sewer Lateral (V.C.P.)
33	Fire Hydrant Location
34	Fire Hydrant Construction
35	Valve Box Installation
36	Double Check Valve - Back Flow Preventer Assembly and Installation
37A	Thermoplastic Striping
37B	Thermoplastic Striping
38	Fire Hydrant Pavement Marker Location
39	Pavement Marking Legends and Words

*Canceled 3-7-17 Ref. CT'  
Std. Plans 488A & 488B*

## TABLE OF CONTENTS (PART III STANDARD PLANS) – Continued

40	Pavement Marking Arrows
41	Bike Lane
42R	Off Street and On Street Accessible Parking ( <i>Updated 3-7-17</i> )
43	Limit Line Installation
44R	Crosswalk ( <i>Updated 3-7-17</i> )
45	Channelization Devices
46	Typical Lane Closure
47	Street Name Sign
48	Traffic Signs (Stop/Yield)
49	P.C.C. Lighting Foundation
50	Fuse Connector
51	Street Light Base Details and Pullbox Installation
52	Street Light Pole and Number Location
53	Pullbox
54	Chain Link Fence
55	Masonry Non-Access Wall
56	Wooden Rail Barricade
57A	Standard Trash Enclosure
57B	Standard Trash Enclosure Details
58	Slope Grading
59A	Best Management Practices
59B	Concrete Waste Washout Management Plan



**CITY OF SALINAS**

**DEVELOPMENT AND ENGINEERING SERVICES  
DEPARTMENT**

**PART I**

**STANDARD SPECIFICATIONS**





**CITY OF SALINAS  
DEVELOPMENT & ENGINEERING SERVICES DEPARTMENT**

**STANDARD SPECIFICATIONS  
2008 EDITION**

These Standard Specifications shall be used in conjunction with the most current approved version of the California Manual of Uniform Traffic Control Devices (MUTCD) relating to signs and pavement markings, and the State of California, Department of Transportation, Standard Specifications (For Construction of Local Streets and Roads) May 2006 edition and as updated and amended, which shall be referred to as State Standard Specifications. In case of conflict between the State Standard Specifications and the City of Salinas Standard Specifications, the City of Salinas Standard Specifications shall apply.

All work shall be consistent with the requirements of the City of Salinas Grading Standards as well as meeting the latest “Storm Water development Standards” for new development and significant redevelopment projects, and the City’s NPDES Permit, which can be found on the City’s webpage [www.ci.salinas.ca.us](http://www.ci.salinas.ca.us) or copies may be obtained at Development and Engineering.

Sections 2 and 9 and portions of all other sections pertaining to payment shall be applicable only to work contracted for by the City of Salinas.

Your attention is directed to Section 1-1.02, “*Abbreviations*,” of these Standard Specifications. Delete the paragraph on the backside of State Standard Specifications title page regarding measurement units.

**SECTION I  
DEFINITIONS AND TERMS**

Definitions and terms shall be as defined in Section 1 of the State Standard Specifications except as herein modified.

Department of Transportation, Department, Director of Transportation, Director, State of California, State, Division of Highways or Chief Engineer when referred to in the State Standard Specifications shall mean the City of Salinas (see Section 1-1.56).

**1-1.02 Abbreviations** - Delete the first two paragraphs following “*Units of Measurements*” and insert the following paragraph:

These “City of Salinas Standard Specifications” contain units in one system of measurement. The standards units established by the City are shown in the United States Standard. The Contractor, Permittee or Developer shall be responsible to insure construction of the work in the units of measurement shown on the Project Plans and Specifications.

**1-1.10 Contractor** - The person or persons, firms, partnership, corporation, or combination thereof, private or municipal, who have either entered into a contract with the City of Salinas, as party or parties of the second part of his/her or their representatives, Permittees authorized or given permission to perform work in, under or about City of Salinas streets, alleys or easements, or Developers authorized to construct improvements that shall be accepted by the City of Salinas

and shall become part of the public property or right-of-way.

**1-1.18 Engineer** - Shall mean the City Engineer duly and officially appointed by the City to supervise and direct the work of construction acting personally or through agents or assistants duly authorized by him/her, such agents or assistants acting within the scope of the particular duties entrusted to them.

**1-1.19 Engineer's Estimate** - The list of estimated quantities of work to be performed as contained in the "Notice to Bidders" and/or contract "Proposal" form.

**1-1.25 Laboratory** - Shall mean the designated laboratory approved by the City of Salinas to test the materials and work involved in a contract.

**1-1.255 Legal Holidays** - Those designated and adopted as official City holidays by the Salinas City Council.

**1-1.37 Special Provisions** - The Special Provisions are specified clauses setting forth conditions or requirements peculiar to the work and supplementary to these Standard Specifications. The State Department of Transportation's publications entitled Labor Surcharge and Equipment Rental Rates, and General Prevailing Wage Rates are to be interpreted to mean the list of rental rates approved by the City Engineer and on file in the office of the City Engineer, and the list of prevailing wage rates as adopted by the City of Salinas and on file in the office of the City Engineer, and shall be considered as a part of the Special Provisions. Copy of the Labor Surcharge and Equipment Rental Rates can be found at <http://www.dot.ca.gov/hq/construc/equipmnt.html>; and copy of General Prevailing Wage Determinations can be found at [http://www.dir.ca.gov/DLSR/statistics\\_research.html](http://www.dir.ca.gov/DLSR/statistics_research.html).

**1-1.49 Right-of-Way** - That area delineated on the Plans or defined in the Special Provisions, which is available to the Contractor.

**1-1.50 Attorney** - The person or persons, firm partnership, or combination thereof duly and officially appointed by the City to act as its legal Counsel.

**1-1.51 State Highway Engineer** - Shall be the Engineer as defined above.

**1-1.52 Local Public Agency** - Shall be the City of Salinas.

**1-1.53 Owner** - Shall be the City of Salinas.

**1-1.54 Provide** - The term "provide" shall mean furnish, install and connect.

**1-1.55 Site** - Shall be as defined in Section 1-1.24, "Highway" and Section 1-1.49, "Right-of-way."

**1-1.56 City of Salinas or City** - Shall mean the City of Salinas, Monterey County, California, acting through the City Council or any board, body, official or officials, which or to whom the power belonging to the Council shall by virtue of any act or acts hereafter passed to be held to appertain.

Where the State Standard Specifications refer to "these Specifications" or to sections within the State Standard Specifications, the reference shall be interpreted as referring to the City of

Salinas, Development and Engineering Services Department, Standard Specifications, 2009 or to sections therein.

Where the State Standard Specifications refer to “Notice to Contractors” it shall be understood to be “Notice to Bidders”.

## **SECTION 2**

### **PROPOSAL REQUIREMENTS AND CONDITIONS**

Proposal requirements and conditions shall be as specified in Section 2 of the State Standard Specifications, except as herein modified.

**2-1.01 Contents of Proposal Forms** - Prospective Bidders shall be furnished with Proposal forms, which shall state the official designation for the job and shall show the estimate of the various quantities and kinds of work to be performed, or materials to be furnished, as a schedule of items for which bid prices are asked.

**2-1.03 Examination of Plans, Specifications, Contract and Site of Work** - The Bidder or contractor shall examine carefully the site of work contemplated, the Plans, Specifications, the Proposal, and Contract forms thereof. The submission of a bid shall be conclusive evidence that the Bidder has investigated and is satisfied as to the conditions to be encountered, as to the character, quality, and scope of work to be performed, the quantities of materials to be furnished, and as to the requirements of the Proposal, Plans, Specifications, and the Contract.

All requests for information (RFI) about the meaning or intent of the Contract Documents shall be submitted to the City Engineer in writing. Replies shall be issued by addenda mailed, faxed or delivered to all parties recorded by the City Engineer as having received the bidding documents. Requests for information (RFI's) received less than ten (10) calendar days prior to the date of the opening of bids shall not be answered. Only questions answered by formal written addenda shall be binding. Oral and other interpretations or clarifications shall be without legal effect.

Where the City has made investigations of subsurface conditions in areas where work is to be performed under the Contract, or in other areas, some of which may constitute possible local material sources, Contractors may, upon written request, inspect the records of the City as to such investigations subject to and upon the conditions hereinafter set forth. Such inspections of records may be made at the office of the City Engineer, Department of Development and Engineering Services, City of Salinas.

The records of such investigations are not a part of the Contract and are shown solely for the convenience of the Bidder or Contractor. It is expressly understood and agreed that the City assumes no responsibility whatsoever in respect to the sufficiency or accuracy of the investigations thus made, the records thereof, or of the interpretations set forth therein or made by the City in its use thereof and there is no warranty or guaranty, either expressed or implied, that the conditions indicated by such investigations or records thereof, or that existing throughout such areas, or any part thereof, that materials other than, or in proportion different from those indicated may not be encountered. Cross-sections and soils investigation report if performed are available at the Development and Engineering Services counter for review. When a log of test borings or other record of geotechnical data obtained by the City's investigation of the subsurface conditions is included with the Contract Plans, it is expressly understood and agreed

that said record does not constitute a part of the Contract, represents only the opinion of the City as to the character of the materials or the conditions encountered by it in its investigations, is included in the Plans only for the convenience of Bidders and its use is subject to all of the conditions and limitations set forth in this section.

In some instances, the information from such subsurface investigations considered by the City to be of possible interest to Contractors has been compiled as "Materials Information" is not a part of the Contract and is furnished solely for the convenience of Bidders and Contractors. It is understood and agreed that the fact that the City has compiled the information from such investigations as "Materials Information" and has exhibited or furnished to the Contractors such "Materials Information" shall not be construed as a warranty or guaranty, express or implied as to the completeness or accuracy of such compilations and the use of such "Materials Information" shall be subject to all the conditions and limitations set forth in this Section 2-1.03 and Section 6-2 "*Local Materials*," of these Standard Specifications.

When contour maps were used in the design of the project, the Bidders and Contractors may inspect such maps, and if available may obtain copies for their use, at their expense.

The availability or use of information described in this Section 2-1.03 is not to be construed in any way as a waiver of the provisions of the first paragraph in this Section 2-1.03 and a bidder or Contractor is cautioned to make such independent investigation and examination as he/she deems necessary to satisfy himself/herself as to conditions to be encountered in the performance of the work and with respect to possible local material sources, the quality and quantity of material available from such property and the type and extent of processing that may be required in order to produce material conforming to the requirements of the Specifications.

No information derived from such inspection of records of investigation or compilation thereof made by the City or from the City Engineer, or his/her assistants, shall in any way relieve the bidder or Contractor from any risk or from properly fulfilling the terms of the Contract.

**2-1.05 Proposal Forms** - All proposal forms shall be obtained from the Development and Engineering Services Department of the City of Salinas, City Hall, Salinas, California.

**2-1.07 Proposal Guaranty** - The proposal guaranty shall be in the form of a certified check or a bidder's bond executed by an insurance company that is an "**Authorized**" carrier by the Insurance Commissioner of the California State Department of Insurance to transact the business of insurance in the State of California, and shall be written by insurers with a current A.M. Best Rating of "A-" or better, and a financial size of "VII" or greater.

**2-1.08 Withdrawal of Proposals** - Any bid may be withdrawn at any time prior to the time fixed in the public notice for the opening of bids only by a written request for the withdrawal of the bid filed with the City Clerk for the City of Salinas.

**2-1.09 Compliance with Local Hiring for Public Works** - Pursuant to Salinas City Code Chapter 12, Article III, the Bidder, Contractor, and Subcontractor(s) shall submit the Local Hiring Residency Compliance Documentation with the Bid Documents or be declared by the City to be a nonresponsive Bidder or Contractor. Once the Contract is awarded, the Bidder, Contractor, or Subcontractor who fails to comply with local hiring practices and is declared an irresponsible Bidder, Contractor, or Subcontractor after an investigation may be disqualified from future projects.

The Bidder, Contractor, and Subcontractor(s) attention is directed to Section 7-1.01A(3), Payroll Records. In addition to the "Certified Payroll" and "Statement of Compliance" that are required weekly, the Bidder, Contractor, and Subcontractor(s) shall submit the "Statement of Good Faith Effort" as required by the Code or be found by the City to be in non compliance and face disqualification pursuant to the Code.

Full compensation for conforming to the requirements of this section shall be considered as included in the Contract prices paid for the various items of work and no additional payment shall be allowed therefore.

**2-1.12 Material Guaranty** - Unless otherwise specified in the Special Provisions, all work shall be required to carry a guaranty against defective material or defective workmanship for a period of one (1) year from the date of formal acceptance by City Council. The signing of the Contract shall be considered as the same as the signing of the guaranty. Upon completion of the Contract and upon the expiration of thirty-five (35) calendar days after formal acceptance of the work, the amounts of the Faithful Performance Bond required in Section 3 may at the Bidder's and Contractor's option be reduced to an amount equal to ten percent (10%) of the total amount of the Contract bid price.

If within one (1) year after the date of formal acceptance any of the work is found to be defective or not in accordance with the Contract Documents, the Contractor shall correct it promptly after receipt of a written notice from the City to do so unless the City has previously given the Contractor a written acceptance of such condition.

Should the Contractor neglect to carry out the work in accordance with the Contract Documents, the City shall, after forty-eight (48) hours, not including Saturdays, Sundays and legal holidays, provide written notice or facsimile to the Contractor and without prejudice to any other remedy he/she may have, make good such deficiencies, and the Contractor shall pay all cost involved including the cost of any necessary engineering expenses. The Contractor shall submit the facsimile phone number.

## **SECTION 3**

### **AWARD AND EXECUTION OF CONTRACT**

Award and execution of Contracts shall be as specified in Section 3 of the State Standard Specifications, except as herein modified.

**3-1.02 Contract Bonds** - In lieu of Section 3-1.02 of the State Standard Specifications the Bidder or Contractor shall furnish two good and sufficient bonds, each of the said bonds to be executed in a sum equal to one hundred percent (100%) of the Contract price each of said bonds. One of the said bonds, the "Performance Bond", shall guarantee the faithful performance of the said Contract by the Contractor. The other said bond, the "Labor and Material Bond" shall be furnished as required by the Public Contract Code to satisfy claims of material suppliers, mechanics and/or laborers employed by it on the work.

Other than requests for reduction of retention funds, all alterations, extensions of time, extra and additional work, and other changes authorized by these Specifications or any part of the Contract may be made without securing the consent of the surety or sureties on the contract bonds.



**3-1.03 Execution of Contract** - In lieu of Section 3 -1.03 of the State Standard Specifications the Contract shall be signed by the successful Bidder or Contractor, and returned, together with the Contract bonds and furnished Certificates of Insurance within ten (10) calendar days after receipt. The City shall not issue the "Notice to Proceed" for the work until all such documents are received and approved. Unless otherwise specified in the Special Provisions, work shall not begin before receipt of the "Notice to Proceed."

**3-1.04 Failure to Execute Contract** - Change "eight (8) days, not including Saturdays, Sundays and legal holidays" to ten (10) calendar days.

## **SECTION 4 SCOPE OF WORK**

Scope of work shall be as specified in Section 4 of the State Standard Specifications except as herein modified.

**4-1.03 Changes** - Add the following paragraphs to this subsection:

A major change is defined as a change in the Contract cost equal to or in excess of ten percent (10%) of the Contract bid award or in excess of the limit set forth in Section 81, "*Public work not paid for by assessment,*" of the City of Salinas Charter and shall be approved by the Salinas City Council before work related to the major change may begin. Although the City is endeavored to process the major change as quickly as possible, the Contractor is advised that such major change may take as long as three (3) weeks after approval by the Contractor to be placed on Salinas City Council Agenda. Time extensions shall be granted for delays to the controlling item of work as a result of processing such major change, however, any impacts as a result of such delay shall be considered included in the price paid for such major change and no additional compensation shall be allowed therefore.

An administrative change is defined as a change in the Contract less than \$50,000.00 and less than the limit set forth in Section 81, "*Public work not paid for by assessment,*" of the City of Salinas Charter and shall be approved by the City Manager, Finance Director and City Engineer of the City of Salinas before work related to the administrative change may begin. Time extensions shall be granted for delays to the controlling item of work as a result of processing such administrative change, however, any impacts as a result of such delay shall be considered included in the price paid for such administrative change and no additional compensation shall be allowed therefore.

**4-1.04 Detours** - Delete any reference to "will be paid for as extra work as provided in Section 4-1.03D" and insert, "if no pay item is provided in the Contract for this work, full compensation for such work shall be considered as included in the prices paid for the various items of work and no additional compensation shall be allowed therefore."

## **SECTION 5 CONTROL OF WORK**

Control of work shall be as specified in Section 5 of the State Standard Specifications, except as herein modified.

**5-1.01 Authority of the City Engineer** - Add the following paragraph:

In prosecuting the provisions of this section or in exercising any power or authority granted to the City Engineer by the Contract, there shall be no liability upon the City Engineer or the City Engineer's authorized representative(s), either personally or as an official of the City and its subsidiary agencies, it being understood that in such matters the City Engineer acts as a representative of the City and its subsidiary agencies.

**5-1.02B Open Trench Excavations Deeper Than Four Feet (4') Below The Surface** - The Contractor shall promptly, and before the following conditions are disturbed, notify the City in writing of any:

1. Materials that the Contractor believes may be material that is hazardous waste, as defined in Section 25117 of the Health and Safety Code, that is required to be removed to a Class I, Class II or Class III disposal site in accordance with the existing law.
2. Subsurface or latent physical conditions at the site differing from those indicated.
3. Unknown physical conditions at the site of any unusual nature, different materially from those ordinarily encountered and generally recognized as inherent in work of the character provided for in the contract.

Should the conditions materially differ or do involve hazardous waste, the removal and disposal of such material shall be paid for as extra work as provided in Section 4-1.03D.

Your attention is directed to Section 9-1.10, "Arbitration," of these Standard Specifications. In the event of a dispute as to whether the conditions materially differ or do involve hazardous waste, the Contractor shall continue to proceed with all work to be performed under the Contract and shall retain all rights provided either by Contract or by law which pertain to the resolution of any dispute or protest.

**5-1.04 Coordination and Interpretation of Plans, Standard Specifications, and Special Provisions** - Delete the second paragraph and insert the following:

If there is a conflict within the Contract Documents, the document highest in precedence shall govern. The precedence shall be:

1. Permits or Codes from other agencies as may be required by law or Ordinance.
2. Special Provisions.
3. Plans
4. Technical Provisions
5. Standard Plans.
6. Standard Specifications
7. Reference Specifications

Plan notes, Change Orders, Supplemental Agreements, and approved revisions to Plans and Specifications shall take precedence over items 2 through 6 above.

**5-1.06 Superintendence** - Add the following to this subsection:

The Contractor's representatives shall not be changed without the consent of the City Engineer and shall notify the City Engineer daily of the following day's proposed work schedule in order to plan for appropriate inspections. The Contractor's Representative shall also submit a Daily Report of the day's construction activity for review and approval. The daily reports shall contain the name of all personnel and equipment, including all subcontractors, and their time working on the various items of work on that day and shall be submitted within twenty-four hours (24 hrs) of that report date. Payment for submitting the Contractor's daily report and notification of the next day work schedule under this section shall be considered included in the prices paid for the various contract items of work and no additional compensation shall be allowed therefore.

**5-1.07 Lines and Grades** - The City Engineer shall establish lines and grades necessary to permit satisfactory completion of the Contract work. The following controls shall be placed for the work under this Contract, at the offset indicated by the Contractor on the construction staking request:

1. Pipes - One reference point shall be set at each end of mains and laterals and at fifty foot (50') intervals for pipe centerline. Each point shall be for both horizontal and vertical control. The centerline of proposed manholes shall be staked with two referenced points with cuts to inlets and outlets.
2. Curb lines and curb grades - The curb line and curb grades for new curb and gutter shall be provided at twenty-five foot (25') intervals, at grade brakes, and at ten or twenty foot (10' or 20') intervals on vertical curves and on curb returns.

The City Engineer shall provide no additional reference for this described work.

3. Street structural sections - Control points shall be provided for the centerline of the roadway at fifty foot (50') intervals, at curves and grade breaks, and at ten or twenty-five foot (10' or 25') intervals on vertical curves.

These points shall be for control of subgrade and proposed centerline grade as shown on the Plans. The Contractor shall use the completed section for control to construct the remaining roadway section. The City Engineer shall provide no additional reference points for the described work.

The Contractor shall preserve and maintain these lines, grades, and benchmarks, and shall lay out there from the work he/she is to perform under the Contract. The Contractor shall be held responsible for the conformance of the completed work to the lines, grades, and benchmarks established by the City Engineer.

The City may withhold the whole or any part of the final payment to such an extent as may be reasonably necessary to protect the City from loss resulting from the Contractor's failure to provide "Record Drawings" Grade Certificates to the City.

**5-1.08 Inspection** Delete the third paragraph and insert the following paragraphs:

Projects financed in whole or in part with Federal Funds, State Funds, or County Funds, shall be subject to inspection at all times by the agency involved.

In all cases where inspection of the work is required and/or where portions of the work are specified to be performed under the direction and/or inspection of the City Engineer, the Contractor shall notify the City Engineer at least forty-eight hours (48 hrs) in advance of the time such inspection and/or direction is required. The Contractor shall not allow nor cause any of his/her work to be covered or enclosed until the City Engineer has inspected it. Should any of his/her work be enclosed or covered before such inspection, the Contractor shall uncover the work at his/her expense and, after inspection, make all repairs necessary to restore his/her work to its original condition at his/her expense.

**5-1.09 Work Done by Others** - The City reserves the right to do other work and to let other Contracts for work contiguous to the work set forth in the Contract.

In the event work is done by the City or by other Contractors or utilities contiguous to work covered by the Contract, the respective rights of the various interests involved shall be established by the City Engineer, and the Contractor shall afford the City and other Contractor's or utilities reasonable opportunity for the introduction and storage of their materials and for the execution of their work, and the Contractor shall properly connect and coordinate the Contractor's work with theirs.

If any part of the work under the Contract depends on proper execution or results upon any other work, the Contractor shall inspect such work and promptly report to the City Engineer any condition which might adversely affect the Contractor's work. The Contractor's failure to so inspect and report shall constitute an acceptance of the other work as fit and proper for the reception of the Contractor's work, except as to deficiencies, which may develop in the other work after the execution of the Contractor's work.

Should this Section 5-1.09 affect the Contractor's progress schedule, time extensions shall be approved. However, that time extension shall include payment for all impacts as a result of this Section 5-1.09. Should there not be a time extension for all impacts as a result of this Section 5-1.09, then no additional compensation shall be allowed therefore.

## SECTION 6

### CONTROL OF MATERIALS

Control of materials shall be as specified in Section 6 of the State Standard Specifications except as herein modified.

**6-3.02 Testing by Contractor** - Delete this subsection in its entirety and insert the following:

The Contractor shall be responsible for controlling the quality of the material entering the work and of the work performed, and shall perform testing as necessary to insure control. The City Engineer shall approve the testing laboratory and methods used for quality control testing. Frequency of testing shall be in accordance Section 8-01, "*Sample Types and Frequencies*", in the California State Department of Transportation Construction

Manual. The results of the quality control tests shall be certified by an Engineer of the testing laboratory and submitted to the City Engineer. These tests are for the use of the Contractor and may be accepted for use as acceptance tests. The Contractor's attention is directed to Section 7-1.04, "Permits and Licenses", of these Standard Specifications concerning "Specialty Testing".

If no pay item is provided in the Contract for the work required under this Section 6-3.02, then full compensation for performing quality control tests, making the certified results available to the City Engineer and Specialty Testing shall be considered as included in the Contract prices paid for the various items of work and no additional compensation shall be allowed therefore.

## SECTION 7

### LEGAL RELATIONS AND RESPONSIBILITY

Legal Relations and responsibility shall be as specified in Section 7 of the State Standard Specifications, except as herein modified.

**7-1.01A(3) Payroll Records** - Reference the next to last sentence of the second paragraph on page 45: Delete the sentence; 'The "Statement of Compliance" shall be on forms furnished by the Department or on any form with identical wording...' and substitute the following sentences: 'The "Statement of Compliance" and "Payroll Report" shall be on forms furnished by the City. A copy of this form is attached to the Special Provisions.'

**7-1.01F Air Pollution Control** - Add the following sentences: The Contractor's attention is directed to Section 10 of these Standard Specifications regarding dust control requirements. The Contractor shall abate dust nuisance by cleaning, sweeping, and sprinkling with water, or other means as necessary during all phases of construction including weekends, holidays, and any other times as directed by the City Engineer. The use of water or other materials that results in mud on the public streets shall not be permitted as a substitute for sweeping. The Contractor shall respond to dust control abatement requests within four hours (4 hrs) of receiving a facsimile notice. The Contractor shall submit the facsimile phone number. Should the Contractor fail to respond to such notice, the City shall cause to have the abatement completed by any available construction force and deduct that cost from any funds due the Contractor. Payment for dust control abatement shall be considered as included in the contract prices paid for the various items of work involved and no additional compensation shall be allowed therefore.

**7-1.01G Water Pollution** - Add to Provision 6 on page 53 of this section the following: No mud, asphalt concrete or cement slurry resulting from saw cutting is allowed to drain into catch basins.

Add the following paragraphs:

In compliance with the Clean Water Act (CWA) and its National Pollutant Discharge Elimination System (NPDES) permit requirements, the Contractor shall submit a Storm Water Pollution Prevention Plan (SWPPP) including the filing of "Notice of Intent" (NOI) to the State Water Resources Control Boards (SWRCB) Regional

Water Quality Control Board (RWQCB) and the City for review. The SWPPP shall contain Best Management Practices (BMPs) for the Contractor's construction activities in accordance with the NPDES permit requirements.

If no pay item is provided in the Contract for work required under this Section 7-1.01G then payment for the NPDES permit and implementation of the SWPPP shall be considered as included in the Contract prices paid for the various items of work involved and no additional compensation shall be allowed therefore.

**7-1.01I Sound Control Requirements** - Add the following: Unless otherwise specified in the Special Provisions or Encroachment Permit, construction work and related activities shall desist between the hours of 9:00 p.m. and the following 7:00 a.m. in accordance with Section 21A-8 of the City Code.

The Contractor's attention is directed to Section 12 -3.03, "*Flashing Arrow Signs*" regarding electrical energy.

**7-1.04 Permits and Licenses** - Add the following paragraphs:

The Contractor and approved Subcontractor(s) shall obtain all necessary licenses (a valid City of Salinas business license), permits, and City of Salinas Transportation permit (including State Permit) prior to beginning of construction.

A "no fee" building permit may be issued. The Contractor shall obtain the permit from the City Permit Services Division. However, should the permit require "specialty testing", the Contractor shall, at his/her expense, provide a certified laboratory that shall submit written test results together with necessary reports to the City Engineer for review and approval.

If no pay item is provided in the Contract for the work required under this Section 7-1.04, then specialty testing including results and reports shall be considered included in Contract prices paid for the various items of work involved and no additional compensation shall be allowed therefore.

**7-1.08 Public Convenience** - All items listed under this section, including "extra work as provided in Section 4-1.03D" and "flagging costs", shall be considered as included in the prices paid for the various Contract items of work and no additional compensation shall be allowed therefore. If the Special Provisions call for the erection, within or adjacent to the limits of the Contract, of warning and directional signs or information signs furnished by the City, and no bid item is included for such erection and return of said signs to the storage location, then the work shall be considered as included in the prices paid for the various Contract items of work and no additional compensation shall be allowed therefore.

**7-1.09 Public Safety** - All items listed under this section, including "flagging costs", and the payment therefore shall be considered as included in the prices for the various Contract items of work and no additional compensation shall be allowed therefore. If the Special Provisions call for the erection within or adjacent to the limits of the Contract, of warning and directional signs or information signs furnished by the City, and no bid item is included for such erection and return of said signs to the storage location, then the work shall be considered as included in the prices paid for the various Contract items of work and no additional compensation shall be allowed therefore.

Whenever immediate action is required to prevent impending injury, death, or property damage, and precautions which are the Contractor's responsibility have not been taken and are not expected to be taken, the City may, after reasonable attempts to notify the Contractor, cause such precautions to be taken and shall charge the cost thereof against the Contractor, or may deduct such cost from any amount due or becoming due from the City. City action or inaction under such circumstances shall not be construed as relieving the Contractor or his/her surety from liability.

Unless otherwise provided by the City Engineer, the Special Provisions, or the Permit, the Contractor's construction activities daily work time shall be between the hours of 8:30 a.m. and 4:30 p.m. on all City streets, alleyways, or other public thoroughfare. Should the Special Provisions or Permit allow for working hours other than listed above and unless otherwise specified in the Special Provisions or Permit, construction work and related activities shall desist between the hours of 9:00 p.m. and the following 7:00 a.m. and, all Saturdays, Sundays, and legal Holidays.

**7-1.09A Street Closures** - Unless otherwise provided in the Special Provisions or Encroachment Permit, street closures shall not be allowed. Should street closure be allowed, the Contractor shall comply with all applicable State, County, and City requirements for closure of streets. No street closure shall be allowed without an approved plan showing barricading, signing and necessary detour signing in accordance with the latest edition of the "Manual of Warning Signs, Lights and Devices for Use in Performance of Work Upon Highways" as published by the California Department of Transportation.

The Contractor shall notify the Police, Fire, Ambulance Service, Disposal Service, affected School Districts, Monterey-Salinas Transit, Engineering Department of jurisdictional agencies involved, affected property owners and businesses, and news media (radio, TV, newspaper) at least seventy-two hours (72 hrs) in advance of any work that shall delay traffic on any street, alleyways or other public thoroughfare. The Contractor shall cooperate with local authorities relative to handling traffic through the area and shall make his/her own arrangements relative to keeping the working area clear of parked vehicles.

The Contractor's attention is directed to Section 7-1.09, "Public Safety". The Contractor shall also be responsible for compliance with additional public safety requirements that may arise during construction. He/she shall furnish, install, and maintain, and upon completion of the work, promptly remove all signs and warning devices. Payment for this work shall be considered as included in the prices paid for the various Contract items of work and no additional compensation shall be allowed therefore.

**7-1.12 Responsibility for Damage** - Section 7-1.12 of the State Standard Specifications shall apply, except that retention of money due the Contractor under and by virtue of the Contract shall be made by the City of Salinas pending disposition of suits or claims for damages brought against the City.

The Contractor shall indemnify and hold harmless the City of Salinas and all officers and employees thereof connected with the work, including but not limited to the City Engineer, from all claims, suits or actions of every name, kind and description, brought for, or on account of, injuries to or death of any person or damage to property resulting from the construction of the work or by or in consequence of any negligence guarding the work; use of improper materials in construction of the work; or by any act or omission by the Contractor or his/her agents during the

progress of the work or at any time before its completion and final acceptance.

The duty of the Contractor to indemnify and save harmless, as set forth herein, shall include the duty to defend, as set forth in Section 2778 of the Civil Code, provided, however, that nothing herein shall be construed to require the Contractor to indemnify the City against any responsibility or liability in contravention of Section 2782 of the Civil Code, including any loss from a design defect which is the sole negligence of the City.

The Contractor shall, at his/her own expense, procure and at all times during the prosecution of the work and until final completion thereof, maintain in full force and effect Workmen's Compensation Insurance, public liability insurance, and property damage insurance conforming with Section 7-1.12 of the State Standard Specifications with the following provisions:

1. A policy covering the full liability of the Contractor to any and all persons employed by him/her directly or indirectly in or upon the work or their dependents in accordance with the provisions of the Labor Code of the State of California relating to Workmen's Compensation Insurance.
2. A policy of public liability and property damage insurance having limits of not less than the limits specified in the State Standard Specifications.

The policies mentioned in this section shall be issued by an insurance carrier satisfactory to the City and shall be delivered to the City at the time of the delivery of such Contract. In lieu of actual delivery of such policies, a certificate issued by the insurance carrier showing such policies to be in force for the period covered by the Contract shall be accepted. Such policies or certificates shall be on the form included in the Contract documents or approved by the City Attorney. Should any policy be cancelled before the final completion of the work herein contemplated and the Contractor should fail to immediately procure other insurance as herein required, then the City may procure such insurance and deduct the cost thereof from the amount due the Contractor. The policies shall by proof of an endorsement include as additional insured the City of Salinas, its officers, agents, and employees.

**7-1.15 Relief from Maintenance and Responsibility** - Add to the last sentence of the last paragraph, "... *or during the warranty period*".

## SECTION 8

### PROSECUTION AND PROGRESS

Prosecution and progress shall be as specified in Section 8 of the State Standard Specifications, except as herein modified.

#### **8-1.01 Subcontracting:**

Delete paragraph 5 of this section and insert the following:

Enclosed with his/her bid, the Contractor shall file with the City Engineer at his/her office, City Hall, Salinas, California, a written statement showing the work to be Subcontracted giving the names of the subcontractors and the description of each portion of the work to be so subcontracted. Requests for substitution or addition of



Subcontractors from the list shall be in accordance with Public Contracts Code Section 4107 and all cost shall be borne by the Contractor.

**8-1.03 Beginning of Work** - Add the following to this subsection:

Before work may begin and the Notice to Proceed issued, a pre-construction conference shall be held at the office of the City Engineer for the purpose of discussing with the Contractor the scope of work, Contract drawings, Specifications, existing conditions, materials to be ordered, equipment to be used, and all essential matters pertaining to the prosecution of and the satisfactory completion of the project as required. The Contractor's representative(s) at this conference shall include all major superintendents for the work including major Subcontractors. The Contractor shall submit at the pre-construction conference a Progress Schedule in accordance with Section 8-1.04 and any other item required by the Special Provisions for review and/or approval.

At the project pre-construction meeting, the City shall furnish two (2) sets of the Plans and Specifications to the Contractor and one (1) additional set for each of the listed Subcontractors. If additional sets are requested, the Contractor shall be charged for the extra sets at the rate specified in the Notice to Bidders.

On or before the date of final inspection, the Contractor shall deliver the corrected and completed "Record Drawings" to the City Engineer. Contractor shall furnish in duplicate two (2) binders of all manufacturer's brochures, manuals, parts list, instructions, etc., for all electrical and mechanical equipment furnished and installed by the Contractor. Submissions of the binder contents in a haphazard method shall not be acceptable. Failure to submit the "Record Drawings" shall be cause to withhold final payment and not accept the project.

**8-1.04 Progress Schedule** - Shall be as specified in Section 8-1.04 of the State Standard Specification, except as herein modified. Delete the first paragraph and insert the following:

The Contractor shall submit to the City Engineer a practicable progress schedule at the beginning of the pre-construction conference, and within five (5) working days of the City Engineer's request at any other time.

**8-1.041 Schedule Review** - Once every week, on a date mutually agreed upon, a jobsite meeting shall be held to review the Construction Schedule, job progress, subsequent work, coordination with public agencies or other Contractors as required and allow the City Engineer to plan his/her activities for testing, inspection, etc.

**8-1.06 Time of Completion** - Shall be as specified in Section 8-1.06 of State Standard Specification, except as herein modified.

Working days shall be counted beginning on the first working day after the day specified on the notice to proceed with the work. Numbered working days shall be in accordance with Caltrans Construction Workday Calendar.

**8-1.08 Termination of Control** - If at any time the City Council shall find that the Contractor has failed to supply an adequate working force or material of proper quality or has failed in any other respect to prosecute the work with diligence as specified in and by the terms of the Contract, notice thereof in writing shall be served upon him/her, and should he/she neglect

or refuse to provide means for satisfactory compliance with the Contract as directed by the City Engineer within the time specified in such notice, the City Council shall have a grounds for termination of the Contractor's control over the work and for taking over the work by the City. Upon receiving notice of such suspension, the Contractor's control shall terminate and thereupon the City Council or its duly authorized representative may take possession of the work or such designated part thereof, and may use any or all of the Contractor's plant, tools, equipment, materials or other property on the work, none of which shall be removed by the Contractor so long as they may be required for the work, and the City Engineer may Contract or otherwise provide the superintendents, workmen, materials, appliances, and equipment necessary for the completion of and may complete the work, or such designated part thereof. The whole of the expense so incurred for the completion of the work or part thereof, together with all damages, liquidated or otherwise, sustained or to be sustained by the City, shall be deducted from the fund or appropriation set aside for the purpose of the Contract and shall be charged to the Contractor as if paid to him/her. In case the amount of such expenses and damages shall exceed the sum which would have been payable under the Contract if completed entirely by the Contractor, the amount of such excess shall be paid to the City by the Contractor and both he/she and his/her sureties shall be liable to the City therefore, and in case the amount of such expense and damages shall be less than the sum which would have been payable under the Contract if completed entirely by the Contractor, he/she shall be entitled to the amount of the difference subject to all the terms of the Contract.

The Contractor shall continue to prosecute to completion all the work from which he/she has not, as above provided, been ordered to desist and he/she shall cooperate with and in no way hinder or interfere with the forces employed by the City or Contract otherwise to do any designated part of the work as above specified.

Upon completion of all the work included under the Contract, the Contractor shall be entitled to the return of all his/her materials which have not been used in the work, of his/her plant, tools, and equipment, provided however that he/she shall have no claim on account of usual and ordinary depreciation, loss, wear, and tear.

In the determination of the question whether there has been any such noncompliance with the Contract as to warrant the suspension or annulment thereof, the decision of the City Council shall be binding on all parties to the Contract.

**8-1.10 Utility and Non-Highway Facilities** - Delete the Subsection in its entirety and insert the following:

- (a) *Location* - The City and the Permittee (in the case of Private Contracts) shall search known substructure records and furnish the Contractor with copies of documents which describe the location of utility substructures, or shall indicate on the Plans for the project those substructures (except for service connections) which may affect the work.

Where underground main distribution conduits such as water, gas, sewer, electric power, telephone, or cable television are shown on the Plans, the Contractor shall assume that every property parcel shall be served by a service connection for each type of utility.

As provided in Section 4216 of the California Government Code, the Contractor shall coordinate with the utility companies to locate and mark all utility mains and service laterals within the project area. Contractor shall make full termination of all underground utilities, including pot holing, in order to prevent damage or disruption to

the existing services during construction. At least two (2) working days prior to commencing any excavation, the Contractor shall contact the regional notification center, Underground Service Alert (USA), and obtain an inquiry identification number. The toll free number to call is: 1-800-642-2444 or 1-800-227-2600.

The California Department of Transportation is not required by Section 4216 to become a member of the regional notification center. The Contractor shall contact their local office at 850 Elvee Drive, Salinas, CA or call at (831) 783-3000 for location of its subsurface installations.

The Contractor shall determine the location and depth of all utilities, including service connections, which have been marked by the respective owners and which may affect or be affected by its operations. If no pay item is provided in the Contract for this work, full compensation for such work shall be considered as included in the prices paid for various Contract items of work and no additional compensation shall be allowed therefore.

- (b) *Protection* - The Contractor shall not interrupt the service function or disturb the support of any utility without authority from the owner or order from the City. All valves, switches, vaults, and meters shall be maintained readily accessible for emergency shutoff.

Where protection is required to ensure support of utilities located as shown on the Plans or in accordance with 8-1.10, the Contractor shall, unless otherwise provided, furnish and place the necessary protection at his/her expense.

Upon learning of the existence and location of any utility omitted from or shown incorrectly on the Plans, the Contractor shall immediately notify the City Engineer in writing. When authorized by the City Engineer, support or protection of the utility shall be paid for as provided in Section 4-1.03.

The Contractor shall immediately notify the City Engineer and the utility owner if any utility is disturbed or damaged. The Contractor shall bear the cost of repair or replacement of any utility damaged if located as noted in Section 8-1.10(a).

When placing concrete around or contiguous to any non-metallic utility installation, the Contractor shall at his/her expense:

1. Furnish and install a two inch (2") cushion of expansion joint material or other similar resilient material; or
2. Provide a sleeve or other opening which shall result in a two inch (2") minimum clear annular space between the concrete and the utility; or
3. Provide other acceptable means to prevent embedment in or bonding to the concrete.

Where concrete is used for backfill or for structures which would result in embedment, or partial embedment, of a metallic utility installation; or where the coating, bedding or other cathodic protection system is exposed or damaged by the Contractor's operations, the Contractor shall notify the City Engineer and arrange to secure the advice of the affected utility owner regarding the procedures required to maintain or restore the

integrity of the system. Cost for such procedures shall be borne by the Contractor at his/her expense.

- (c) *Removal* - Unless otherwise specified, the Contractor shall remove all conflicting portions of utilities shown on the Plans or indicated in the bid documents as “abandoned” or “to be abandoned-in-place”. Before starting removal operations, the Contractor shall ascertain from the City whether the abandonment is complete. If no pay item is provided in the Contract for this work, full compensation for such work shall be considered as included in the prices paid for various items of work and no additional compensation shall be allowed therefore.
- (d) *Relocation* - When feasible, the owners responsible for utilities within the area affected by the work shall complete the necessary installations, relocations, repairs, or replacements before commencement of work by the Contractor. When the Plans or Specifications indicate that a utility installation is to be relocated, altered, or constructed by others, the City shall conduct all negotiations with the owners and work shall be done at no cost to the Contractor, except as provided in Section 15-2.05A. Utilities that are relocated in order to avoid conflicts shall be protected in their position. If no pay item is provided in the Contract for protection, full compensation for such work shall be considered as included in the prices paid for various items of work and no additional compensation shall be allowed therefore.

After award of the Contract, portions of utilities that are found to conflict with the work shall be re-arranged by the utility owners, or the City Engineer may order changes in the work to avoid the conflict. Such changes shall be paid for in accordance with Section 4-1.03.

When the Plans or Specifications provide for the Contractor to alter, relocate, or reconstruct a utility, all cost for such work shall be included in the bid for the items of work necessitating such work. Temporary or permanent relocation or alteration of utilities requested by the Contractor for Contractor’s convenience shall be the Contractor’s responsibility and the Contractor at his/her cost shall make all arrangements.

The utility owner shall relocate service connections as necessary within the limits of the work or within temporary construction or slope easements. When directed by the City Engineer, the Contractor shall arrange for the relocation of service connections as necessary between the meter and property service line, or between a meter and the limits of temporary construction or slope easements. The relocation of such service connections shall be paid for in accordance with the provisions in Section 4-1.03. Payments shall include the restoration of all existing improvements, including landscaping, which may be affected thereby. The Contractor may agree with the owner of any utility to disconnect and reconnect interfering service connections and shall notify the City of any such agreement.

- (e) *Delays* - The Contractor shall notify the City Engineer of its construction schedule insofar as it affects the protection, removal, or relocation of utilities. Said notification shall be included as a part of the construction progress schedule required in Section 8-1.04. The Contractor shall notify the City Engineer in writing of any subsequent changes in the construction schedule that shall affect the time available for protection, removal, or relocation of utilities.

The Contractor shall not be entitled to damages or additional payment for delays attributable to utility relocations or alterations if correctly located, noted, and completed in accordance with Section 5-1.09 and Section 8-1.10(a).

The City shall assume responsibility for the timely removal, relocation, or protection of existing main or trunkline utility facilities within the area affected by the work if such utilities are not identified in the Contract Documents. The Contractor shall not be assessed liquidated damages for any delay caused by failure of the City to provide for the timely removal, relocation, or protection of such existing facilities.

If the Contractor sustains loss due to delays attributable to conflicts, relocations, or alterations not covered by Section 8-1.10(a), which could not have been avoided by the judicious handling of forces, equipment, or plant, there shall be paid to the Contractor such amount as the City Engineer may find to be fair and reasonable compensation for such part of the Contractor's actual loss as was unavoidable and the Contractor may be granted an extension of time.

- (f) *Cooperation* - When necessary, the Contractor shall so conduct its operations as to permit access to the work site and provide time for utility work to be accomplished during the progress of the work. Cost as a result of cooperation shall be included in the prices paid for the various Contract items of work and no additional compensation shall be allowed therefore.
- (g) *Payment* - If no pay item is provided in the Contract for work required under this Section 8-1.10, full compensation for such work shall be considered as included in the prices paid for various Contract items of work and no additional compensation shall be allowed therefore.

## SECTION 9

### MEASUREMENT AND PAYMENT

**9-1.01 Measurement of Quantities** - Shall be as specified in Section 9 of the State Standard Specifications except as herein modified. In lieu of the portion of Section 9-1.01 of the State Standard Specifications which provides that roadway material, except imported borrow and imported topsoil, shall have the weight of the water deducted from the weight of the material delivered to the work, the complete weight of the material shall be the measurement upon which payments shall be based, provided, however, that the moisture content does not exceed the optimum moisture for compaction of the material.

Add the following to this section: The Contractor's attention is directed to Section 1-1.02. In addition to the units of measurement, insert the following:

#### UNITS OF MEASURE AND THEIR ABBREVIATIONS

##### U.S. Customary Unit (Abbreviations)

1 mil (= 0.001 in)

1 inch (in)

1 inch (in)

1 foot (ft)

1 yard (yd)  
1 mile (mi)  
1 square foot (ft<sup>2</sup>)  
1 square yard (yd<sup>2</sup>)  
1 cubic foot (ft<sup>3</sup>)  
1 cubic yard (yd<sup>3</sup>)  
1 acre  
1 U.S. gallon (gal)  
1 fluid ounce (fl. oz.)  
1 pound mass (lb)(avoirdupois)  
1 ounce mass (oz)  
1 ton (=2000 lb avoirdupois)  
1 Poise  
1 centistoke (cs)  
1 pound force (lbf)  
1 pounds per square inch (psi)  
1 pound force per foot (lbf/ft)  
1 foot-pound force (ft-lbf)  
1 foot-pound force per second ([ft-lbf]/s)  
1 part per million (ppm)

#### **TEMPERATURE UNIT AND ABBREVIATIONS**

Degree Fahrenheit (°F):

$$^{\circ}\text{F} = (1.8 \times ^{\circ}\text{C}) + 32$$

#### **SI UNITS (ABBREVIATION) COMMONLY USED IN BOTH SYSTEMS**

1 Ampere (A)  
1 Volt (V)  
1 Candela (cd)  
1 Lumen (lm)  
1 second (s)

**9-1.02 Scope of Payment** - In addition to this subsection, add the following paragraph:

Items of labor and materials which are not specifically listed in the Proposal and the Special Provisions as pay items, but which are shown and/or mentioned on the Plans or are required to be done to complete the overall project, shall be considered included in prices paid in the various Contract items of work and no additional compensation shall be allowed therefore.

**9-1.06 Partial Payments** - Delete the third paragraph of this subsection and insert the following paragraphs:

The Department shall retain ten percent (10%) of such estimated value of the work done and ten percent (10%) of the value of materials so estimated to have been furnished and

delivered and unused or furnished and stored as aforesaid as part security for the fulfillment of the Contract by the Contractor, except that at any time after fifty percent (50%) of the work has been completed, if the City Engineer finds that satisfactory progress is being made, the City Engineer may reduce the total amount being retained from payment pursuant to the above requirements to five percent (5%) of the total estimated value of said work and materials and may also reduce the amount retained from any of the remaining partial payments to five percent (5%) of the total estimated value of said work and materials and may also reduce the amount retained from any of the remaining partial payment to five percent (5%) of the estimated value of such work and materials. The request to lower the retention shall be made in writing by the Contractor, along with a written approval by the surety of the performance and payment bonds. The retained security shall be paid to the Contractor thirty-five (35) calendar days after the work has been formally accepted by the City Council.

The Contractor shall submit Subcontractor(s) and/or supplier(s) waiver of liens as required by Civil Code Article 3262. The waiver shall be "conditional" before payment and "unconditional" after payment on forms set forth in the statute.

**9-1.061 Beneficial Use** - As a condition to partial payments made to the Contractor, the City shall have the right to make beneficial use of completed portions of the work prior to total project completion without prejudice to completion and final acceptance of the project.

**9-1.065 Payment of Withheld Funds** - Delete the second paragraph of this subsection and insert the following paragraph:

As provided in Section 22300 of the Public Contract Code and Section 10263 of the Government Code, Contractor within ten (10) calendar days after award of the Contract may request that any retention to be withheld during the course of a project is paid to an escrow agent at the Contractor's expense. Should the Contractor make such request, it shall be required that an appropriate Escrow Agreement as provided in said Government Code be fully executed prior to any payment of retention withheld, and in keeping with the City's Local Hire policy, the Escrow Agent shall be from a local Salinas bank or agency. The City Engineer, or his/her delegate, is authorized to execute said Escrow Agreement on behalf of the City.

**9-1.07B Final Payment and Claims** - In lieu of the portions of Section 9-1.07 of the State Standard Specifications, which provide thirty (30) calendar days for the Contractor to submit written approval of the proposed final estimate to the City Engineer or thirty (30) calendar days to file a claim, ten (10) calendar days time shall be permitted in these Specifications.

On the Contractor's approval or if he/she files no claim within said period of ten (10) days, the City Engineer shall issue a final estimate in writing in accordance with the proposed final estimates submitted to the Contractor and within thirty-five (35) calendar days thereafter, the City shall pay the entire sum so found to be due.

Such final estimate and payment thereon shall be conclusive and binding against both parties to the Contract and all questions relating to the amount of work done and any compensation payable therefore.

If the Contractor within said period of ten (10) calendar days files a claim(s), the City Engineer shall issue a semifinal estimate in accordance with the proposed final estimates

submitted to the Contractor and within thirty-five (35) calendar days thereafter, the City would pay the sum so found to be due. Such semifinal estimate and payment thereon shall be conclusive and binding against both parties to the Contract as they relate to the amount of work done and the compensation payable thereto except items affected by the claim(s) filed within the time and the manner required hereunder.

Delete the fourth paragraph and insert the following paragraph:

The City Council shall make the final determination of any claim(s), which remain in dispute after completion of claim review by the Division administering the Contract. The City Engineer shall review such claims and make a written recommendation thereon to the City Council. The Contractor may meet with the City Engineer to make a presentation in support of such claim(s).

**9-1.07C Satisfaction of Liens** - Prior to judicial determination of any claim(s) or in accordance therewith, the City may apply any amount withheld to the payment and satisfaction of recorded liens or just claim(s) against the Contractor or any Subcontractors for labor and services rendered and materials furnished. In so doing, the City shall be deemed the agent of the Contractor and any payment so made by the City shall be considered as a payment made under the Contract by the City to the Contractor, and the City shall not be liable to the Contractor for any payment made in good faith; provided that such payment shall not be made except by court order if the Contractor furnishes a bond satisfactory to the City to indemnify it against any lien or claim(s).

For timely Stop Notices, City shall withhold funds from Contractor's payment in compliance with State Law.

**9-1.08 Adjustment of Overhead Costs** - The provisions in the State Standard Specifications shall not apply.

## **SECTION 10 DUST CONTROL**

Dust control shall be as specified in Section 10 of the State Standard Specifications, except as herein modified.

**10-1.03 Cleanup** - Throughout all phases of construction including suspension of work, and until receiving relief from maintenance and responsibility for the project, the Contractor shall keep the work site clean and free from rubbish, debris, and graffiti. The Contractor shall also abate dust nuisance by cleaning, sweeping, and sprinkling with water, or other means as necessary. The use of water is a violation of the NPDES permit and Clean Water Act, and shall not be permitted as a substitute for sweeping or other methods. The Contractor shall respond to dust control abatement requests within four hours (4 hrs) of receiving a facsimile notice. The Contractor shall submit the facsimile phone number. Should the Contractor fail to respond to such notice, the City shall cause to have the abatement completed by any available construction force and deduct that cost from any funds due the Contractor.

Failure of the Contractor to comply with the City Engineer's clean up orders may result in an order to suspend the work until the condition is corrected. No additional compensation shall be allowed as a result of such suspension.



**10-1.04 Payment** - In lieu of Section 10-1.04 of the State Standard Specifications, full compensation for all expense involved in conforming to the above cleanup requirements or for applying either water or dust palliative shall be considered as included in the unit prices paid for the various items of work and no additional compensation shall be allowed therefore.

## **SECTION 11 MOBILIZATION**

Mobilization shall be as specified in Section 11 of the State Standard Specifications.

## **SECTION 12 CONSTRUCTION AREA TRAFFIC CONTROL DEVICES**

Construction Area Traffic Control Devices shall be as specified in Section 12 of the State Standard Specifications except as herein modified.

**12-2.02 Flagging Costs** - Delete the first paragraph and insert the following:

The cost of furnishing all flaggers, including transporting flaggers, to provide for passage of public traffic through the work under provisions in Sections 7-1.08, "*Public Convenience*," and 7-1.09, "*Public Safety*," and for providing stands or towers for use of flaggers shall be considered included in the prices paid for the various Contract items of work and no additional compensation shall be allowed therefore.

**12-3.03 Flashing Arrow Signs** - Unless otherwise provided in the Special Provisions, a generating plant onsite to provide electrical energy shall not be allowed.

**12-3.08 Temporary Railing (Type K)** - Delete the last sentence of the first paragraph and insert the following sentence: Payment for repainting of the units when ordered by the City Engineer shall be included in the prices paid for the various Contract items of work and no additional compensation shall be allowed therefore.

**12-3.12 Portable Changeable Message Signs** - Unless otherwise provided in the Special Provisions, or directed by the City Engineer, a generating plant onsite to provide electrical energy shall not be allowed.

**12-4 Measurement and Payment** - Delete all reference to "*will be paid for as extra work as provided in Section 4-1.03D...*" and substitute, shall be included in the prices paid for the various Contract items of work and no additional compensation shall be allowed therefore.

## **SECTIONS 13 AND 14 (BLANKS)**

## **SECTION 15 EXISTING HIGHWAY FACILITIES**

Existing highway facilities shall be as specified in Section 15 of the State Standard Specifications, except as herein modified.

**15-2.02A Obliterating Roads and Detours** - Unless otherwise specified in the Special Provisions, obliterating shall consist of removal of all asphalt, concrete or Portland cement concrete pavement and rooting, plowing, pulverizing or scarifying to a minimum depth of one half foot (0.5') or to the bottom of the base material, whichever is less. The loosened material shall be shaped to provide a presentable and well-drained area.

**15-2.05A Frames, Covers, Grates, and Manholes** - Structures located in the pavement area may be constructed to final grade prior to completion of the pavement or surfacing.

Manholes that are to be lowered to a degree that the frame shall be supported with existing structure on more than fifty percent (50%) of its base width at any point, may be lowered without removal of the concrete required in Section 15-2.05A of the State Standard Specifications.

**15-2.07 Payment** - Delete the last two paragraphs and insert the following:

When the Contract does not include a separate item(s) for removing any of the existing highway facilities encountered within or outside the project limits, then payment for removing such facilities shall be included in the Contract prices paid for the various Contract items of work and no additional compensation shall be allowed therefore.

**15-3.02 Concrete Removal Methods** - In addition to the Specifications in Section 15-3.02 of the State Standard Specifications, existing concrete shall be cut to a true line where new concrete is to join existing concrete using a concrete saw cutting to a minimum depth of one and on-half inches (1-1/2") or to a depth as shown on the Plans or as specified in the Special Provisions.

**15-3.04 Removing Concrete Payment** - When the Contract does not include a separate bid item for removal of concrete, then payment for removing concrete shall be included in the Contract prices paid for the various Contract items of work and no additional compensation shall be allowed therefore.

## **SECTION 16**

### **CLEARING AND GRUBBING**

In addition to the requirements of Section 16 of the State Standard Specifications relating to clearing and grubbing, all work shall be in compliance with the requirements of the Grading Standards, Section 2 "Low Impact Development & Stormwater Quality Planning", Section 3 "Site and Facility Design" of the most current edition of "The City Of Salinas Storm Water Development Standards for New Development and Significant Redevelopment Projects", which may be found on the City's webpage [www.ci.salinus.ca.us](http://www.ci.salinus.ca.us) or copies may be obtained at Development and Engineering.

## **SECTION 17**

### **WATERING**

Watering shall be as specified in Section 17 of the State Standard Specifications, except as herein modified.

**17-1.04 Payment** - In lieu of Section 17-1.04 of the State Standard Specifications, full compensation for developing the water supply for all water required for the work and for furnishing and applying all water shall be considered as included in the prices paid for the various Contract items of work and no additional compensation shall be allowed therefore.

## **SECTION 18 DUST PALLIATIVE**

Dust Palliative shall be as specified in Section 18 of the State Standard Specifications, except as herein modified.

**18-1.05 Payment** - Delete the provisions of the State Standard Specifications in its entirety and insert the following paragraph:

If no pay item is provided in the Contract for work required under this Section 18, then full compensation for such work shall be considered as included in the prices paid for in the various items of work and no additional compensation shall be allowed therefore.

## **SECTION 19 EARTHWORK**

All work shall be in compliance with the requirements of the Grading Standards, Section 2 “Low Impact Development & Stormwater quality Planning”, Section 3 “Site and Facility Design” of the most current edition of “The City Of Salinas Storm Water Development Standards for New Development and Significant Redevelopment Projects”, which may be found on the City’s webpage [www.ci.salinas.ca.us](http://www.ci.salinas.ca.us) or copies may be obtained at Development and Engineering.

Earthwork shall be as specified in Section 19 of the State Standard Specifications, except as herein modified.

**19-1.03 Grade Tolerance** - In lieu of the applicable provisions in Section 19-1.03 of the State Standard Specifications, the grading plane shall not vary more than five-hundredths/foot (0.05’) above or below the grade established by the City Engineer.

**19-2.01A Preparation of Subgrade** - Scarifying, subsoiling and discing shall be required under the following conditions as determined by the City Engineer:

1. For dry soils which are impervious to the penetration of water.
2. For soils that may contain excessive amounts of moisture which may result in unstable foundations.
3. For soils which are non-uniform in character which may result in non-uniform compactions and may result in differential settlements of finished surfaces.
4. When pavement is to be placed directly on the roadbed subgrade.

After rough grading has been completed and scarifying and discing are required, the roadbed subgrade shall be loosened to a depth of at least six inches (6”). The loosened

material shall then be worked to a finely divided condition and all rocks larger than three inches (3”) in diameter removed. The moisture content shall be brought to optimum by the addition of water, by the addition and blending of dry suitable material or by the drying of existing material. The material shall then be compacted by approved equipment to the specified relative compaction. If no pay item is provided in the Contract for this work, then full compensation for such work shall be considered as included in the prices paid for various items of work and no additional compensation shall be allowed therefore.

**19-2.06 Surplus Material** - Delete the first paragraph of this subsection and insert the following paragraph: Unless otherwise shown on the Plans or specified in the Special Provisions, surplus excavated material shall become the property of the Contractor and shall be disposed of off the site of the work in a manner approved by the City Engineer. If no pay item is provided in the Contract for this work, the full compensation for such work shall be considered as included in the prices paid for various items of work and no additional compensation shall be allowed therefore.

**19-3 Structure Excavation and Backfill** - Reference to this section in the State Specifications Sections 61, 62, 64, 65, 66, and 68 that apply to culverts, pipes, rods, and deadmen shall be in accordance with Section 19-4, “*Open Trench Operations*” of these Standard Specifications.

**19-3.06 Structure Backfill** - Delete the first ten (10) paragraphs of this subsection and insert the following:

Except when used at certain locations hereinafter described, material for use as structure backfill shall have a sand equivalent value of not less than thirty (30). The percentage composition by weight as determined by laboratory sieves shall conform to the following grading:

<b>SIEVE SIZES</b>	<b>PERCENTAGE PASSING</b>
3 inch	100
No. 4	35-100

Structure backfill shall not be placed until the structure footings or other portions of the structure or facility have been inspected by the City Engineer and approved for backfilling. No backfill materials shall be deposited against the back of concrete abutments, concrete retaining wall, or outside walls of cast-in-place concrete structures until the concrete has developed a strength of not less than twenty-five hundred psi (2,500 psi) of compressive strength as determined by test cylinders cured under conditions similar to those prevailing at the site and tested in accordance with Test Method No. Calif. 521.

Backfill material shall be placed in horizontal, uniform layers not exceeding sixty-seven hundredths/foot (0.67’) in thickness, before compaction, and shall be brought up uniformly on all sides of the structure or facility. Each layer of backfill shall be compacted to a relative compaction of not less than ninety percent (90%).

Compaction equipment or methods that produce horizontal or vertical earth pressures, which may cause excessive displacement or may damage structures shall not be used. At the option of the Contractor, backfill material conforming to the requirements

hereinafter specified may be used at the following locations:

1. Footings outside of slope lines and not beneath any roadbed.
2. Footings for slope protection, slope paving, and aprons.
3. All headwalls, endwalls, and culvert wingwalls.
4. Retaining walls, except for portions under any roadbed.
5. Inlets in median areas or in traffic interchange loops.

The backfill material at the above locations may consist of material from excavation, free from stones or lumps exceeding three inch (3") in greatest dimension, vegetable matter, or other unsatisfactory material and shall be compacted to a relative compaction of not less than ninety percent (90%). When the material from excavation is unsuitable for use as backfill it shall be disposed of as directed by the City Engineer, and the Contractor at his/her expense for the backfill shall furnish suitable material approved by the City Engineer.

Compaction of structure backfill by jetting shall be permitted when, as determined by the City Engineer, the backfill material is of such character that it shall be self-draining when compacted and that foundation material shall not soften or be otherwise damaged by the applied water and no damage from hydrostatic pressures shall result to the structure. Jetting of the upper four feet (4'), below finished grade shall not be permitted. When jetting is permitted, material for use as structure backfill shall be placed and compacted in layers not exceeding four feet (4') in thickness. The work shall be performed without damage to the structure and embankment, and in such a manner that water shall not be impounded. Jetting methods shall be supplemented with the use of vibratory or other compaction equipment when necessary to obtain the required compaction. Water used for jetting shall be furnished and applied by the Contractor at his/her expense.

**19-3.062 Slurry Cement Backfill** - Delete item (1) in paragraph 6 of this subsection.

**19-4 Open Trench Operations** - Delete Section 19-4, *Ditch Excavation*, in the State Standard Specifications and insert the following:

**19-4.01 Trench Excavation** - For the purpose of shoring or bracing a trench is defined as an excavation in which the depth is greater than the width of the bottom of the excavation. The Contractor's attention is directed to Section 5-1.02B regarding hazardous material encountered during excavation.

Excavations for appurtenant structures, such as but not limited to manholes, transition structures, junction structures vaults, valve boxes, catch basins, thrust blocks, and boring pits shall, for the purpose of shoring and bracing, be deemed to be in the category of trench excavation.

Excavation shall include the removal of all water and materials of any nature, which interfere with the construction work. Appropriate dewatering techniques may be utilized if necessary to lower the ground water levels and to stabilize excavation. Methods used shall be such that there is no danger of pumping soil from excavation, or adjacent areas, during dewatering. The water level shall be lowered at least to an elevation one foot (1') below the bottom of the pipe. This level shall be maintained continuous during construction until after backfilling has been completed up to the original groundwater elevation.

Water pumped during the dewatering operations shall be discharged in accordance with the Clean Water Act (NPDES permit) in a manner such that there is no hazard to the public and a minimum of traffic interference.

The dewatering methods used shall be the responsibility of the Contractor, but subject to approval of the City Engineer. Removal of groundwater to a level below the structure subgrade shall be necessary only when required by the Plans or Specifications. Unless otherwise specified on the Plans or Special Provisions, payment for dewatering shall be considered as included in the prices paid for the various Contract items of work and no additional compensation shall be allowed therefore.

Excavation for conduits, including electrical conduit, shall be by open trench unless otherwise specified on the Plans or Special Provisions. However, should the Contractor elect to tunnel or jack any portion not so specified, he/she shall first obtain approval from the City Engineer. Payment for such work shall be made as though the specified methods of construction had been used.

**19-4.011 Maximum and Minimum Width of Trench** - For pipe (except corrugated steel pipe), the minimum and maximum width of trench permitted shall be as indicated on the Plans or Standard Plans.

For corrugated steel pipe, the trench shall be at least sixteen inches (16") inches wider than the outside diameter of the pipe to be installed.

If the maximum trench width is exceeded, the Contractor at his/her expense shall provide additional bedding, another type of bedding, or a higher strength of pipe, as shown on Plans or approved by the City Engineer.

Additional payments or deductions from the Contract Unit Price per trench excavation for conduits shall be based upon a calculated volume. The width used in calculating the volume of excavation for prefabricated conduit shall be the maximum width of trench shown on the Plan and measured at the top of the pipe. In case of sewers or storm drains formed and cast in place, such volume shall be based upon the outside width of the structure being constructed plus three feet (3').

Additional payment or deductions from Contract Price for trench resurfacing shall be based upon an area determined by the maximum width of trench as specified herein.

**19-4.012 Access to Trenches** - Safe and suitable ladders, which project two feet (2') above the top of the trench shall be provided for all trenches over four feet (4') in depth. One ladder shall be provided for each fifty feet (50') of open trench, or fraction thereof, and be so located that workers in the trench need not move more than twenty-five feet (25') to a ladder.

**19-4.013 Removal and Replacement of Surface Improvements** - Bituminous pavement, concrete pavement, curbs, sidewalks, or driveways removed in connection with construction shall be removed in accordance with Section 16 -1.04 and reconstructed in accordance with Sections 39, 40, or 73.

**19-4.014 Bracing Excavations** - The manner of bracing excavations shall be as set forth in the rules, orders, and regulations of the Division of Industrial Safety of the State of California.

Prior to commencing the excavation of a trench five feet (5') in depth or greater and into which a person shall be required to descend, the Contractor shall first obtain a permit to do so from the Division of Industrial Safety pursuant to Section 7-1.01E.

Should the bracing system utilize steel H-beams or piles or other similar vertical supports, driving of said vertical supports shall not be permitted except for the last four feet (4'). The vertical support shall be placed in holes drilled to a depth of four feet (4') above the proposed bottom of pile, except where this procedure is impracticable. The vertical support may then be driven to the required depth, not to operations, the Contractors shall take care to avoid damage to utilities.

At locations where the drilling of such holes is impracticable because of the existence of rocks, runnings and or other similar conditions, and provided said impracticability is demonstrated to the satisfaction of the City Engineer by actual drilling operations by the Contractor, the City Engineer may, upon request of the Contractor, approve the use of means other than drilling for the purpose of placing the vertical support. Such other means, however, shall be of nature, which shall accomplish, as nearly as possible, the purpose of the drilling, namely, the prevention of damage to existing surface or subsurface improvements, both public and private. All cost for this work shall be considered as included in the prices paid for the various Contract items of work and no additional compensation shall be allowed therefore.

If sheeting is used to support the excavated trench, the Contractor shall remove the sheeting, and no such sheeting shall be permitted to remain in the trench. When field conditions, the type of sheeting, or methods of construction used by the Contractor are such as to make the removal of sheeting impracticable, the City Engineer may permit portions of the sheeting to be cut off to a specified depth and remain in the trench.

**19-4.015 Bedding** - Bedding shall be defined as that material supporting, surrounding, and extending from the trench subgrade to the springline of the pipe. Bedding material shall meet the requirements of Section 19-4.022a of these Standard Specifications.

Where it becomes necessary to remove boulders or other interfering objects at subgrade for bedding, any void below such subgrade shall be filled with the bedding material. Where concrete is specified to cover the pipe, the top of the concrete shall be considered as the top of the bedding.

If soft, spongy, unstable, or other similar material is encountered upon which the bedding material or pipe is to be placed, this unsuitable material shall be removed to a depth of one foot (1') and replaced with bedding material suitably densified. Payment for such removal and replacement shall be considered included in the prices paid for the various Contract items of work and no additional compensation shall be allowed therefore. Additional bedding if so ordered by the City Engineer, over the amount required by the Plans or Specifications, shall be paid for as extra work as provided in Section 4-103D. If the necessity for such additional bedding material has been caused by an act or failure to act on the part of the Contractor or is required for the control of groundwater, the Contractor shall at his/her expense provide for the additional excavation and bedding.

Bedding material shall first be placed on a firm and unyielding subgrade so that the pipe is supported for the full length of the barrel. Unless otherwise specified on the Plans or Special

Provisions, there shall be 4 inches minimum of bedding below the pipe barrel and one inch (1") minimum clearance below a projecting bell. There shall be a minimum side clearance of six inches (6") on each side of the pipe barrel. The bedding shall be placed, and densified by mechanical means to ninety-five percent (95%) relative compaction. Unless the sheeting or shoring is to be cut off and left in place, densification of bedding for pipes shall be accomplished after the sheeting or shoring has been removed from the bedding zone, and prior to the placement of backfill.

Except where otherwise specified, bedding materials shall be gravel or crushed aggregate material having a sand equivalent of not less than thirty (30) or having a coefficient of permeability greater than one and four-tenths inches/hour (1.4 inches/hour), or other material approved by the City Engineer.

In cases where native free-draining granular material is suitable for use as bedding, the trench may be excavated to a point above the invert grade and the trench bottom hand shaped so that the bottom segment of the pipe is firmly supported on undisturbed material.

Unless otherwise specified, special pipe bedding shall not be required for steel or cast iron water pipe, and the trench bottom need not be shaped to the outside diameter of the pipe. However, the trench bottom shall provide firm and uniform bearing.

**19-4.016 Pipe Laying** - Pipe shall be inspected in the field by the City Engineer before and after laying. If any cause for rejection is discovered in a pipe after it has been laid, it shall be subject to rejection. Any corrective work shall be approved by the City Engineer and shall be at no cost to the City.

When connections are to be made to any existing pipe, conduit, or other appurtenances, the actual elevation or position of which cannot be determined without excavation, the Contractor shall excavate for, and expose, the existing improvement before laying any pipe or conduit. The City Engineer shall be given the opportunity to inspect the existing pipe or conduit before connection is made. Any adjustments in line or grade which may be necessary to accomplish the intent of the Plans shall be made, and the Contractor shall be paid for any additional work resulting from such change in line or grade in the manner provided in Section 4-1.03D.

Pipe shall be laid up-grade with the bell, socket, or collar ends of the pipe up-grade unless otherwise authorized by the City Engineer.

Concrete pipe with elliptical reinforcement shall be laid with the minor axis of the reinforcement cage in a vertical position.

Corrugated metal pipe shall be laid with external laps of the circumferential seams toward the inlet end. Corrugated pipes shall be shipped and handled in such a manner as to prevent damage to protective coatings.

When specified, circular corrugated steel pipe shall be elongated in the shop or in the field before backfilling. The pipe shall be vertically elongated from a true circle to provide an increase in the diameter of approximately five percent (5%) for the full length.

Installation of slotted corrugated steel pipe shall not start until after paving of the traffic lanes adjacent to the pipe has been completed at the locations where the pipe is to be placed. The



slots shall be covered with roofing paper or other approved covering during backfilling operations to prevent infiltration of material into the pipe.

Pipe shall be laid per the Plans line and grade, with uniform bearing under the full length of the barrel of the pipe. Suitable excavation shall be made to receive the bell, socket or collar, which shall not bear upon the subgrade or bedding. Any pipe that is not in true alignment or shows any undue settlement after laying shall be taken up and re-laid by the Contractor's at his/her expense.

Pipe sections shall be laid and jointed in such a manner that the offset of the inside of the pipe at any joint shall be held to a minimum at the invert. The maximum offset at the invert of pipe shall be one percent (1%) of the inside diameter of the pipe or three-eighths inch (3/8"), whichever is smaller.

In joining socket-and-spigot pipe, the spigot of each pipe shall be so seated in the socket of the adjacent pipe as to give a minimum of three-eighths inch (3/8") annular space all around the pipe in the socket. Unavailable offsets shall be distributed around the circumference of the pipe in such a manner that the minimum offset occurs at the invert.

When pipe is laid in a sheeted trench, all sheeting against which concrete cradle is to be placed shall be faced with at least one thickness of building paper and the sheeting shall be withdrawn without displacing or damaging the cradle, except as otherwise provided in Section 19-4.015.

After the joints have been made, the pipe shall not be disturbed in any manner.

At the close of work each day, or whenever the work ceases for any reason, the end of the pipe shall be securely closed unless otherwise permitted by the City Engineer.

**19-4.02 Trenching in Improved Areas** - Trenching in improved areas shall be considered to be in any previously paved area, either Portland cement concrete or a asphaltic concrete, on public property or right-of-way, subject to vehicular traffic.

**19-4.021 Trench Excavation** - Except when this requirement is specifically waived by the City Engineer, the trench, at the end of the day, shall not be excavated for more than fifty feet (50') in advance of the pipe laying, or left unfilled for more than fifty feet (50') where the pipe has been laid. At no time shall the trench be open further than two hundred feet (200') in advance of the pipe laying or one hundred feet (100') to the rear thereof, without specific approval of the City Engineer. At the end of the day the exposed trench shall be backfilled to finished grade or covered by a method approved by the City Engineer. These restrictions do not apply to cast-in-place pipe. The finished grade surfaces shall be either temporary bituminous surfacing or permanent pavement.

Trenches shall be dug in such a manner so as to assure that the bottom of the trench shall be true to line and grade and be free of rocks, organic material, and any other deleterious substance. The trench walls shall be cut in such a manner as to provide the proper clearance, in accordance with Standard Plan 16.

When excavating for pipes, conduits, ducts, or lines of any kind, and solid rock or other unyielding material is encountered, additional material shall be removed below the normal trench bottom to a minimum depth of six inches (6") or as directed by the City Engineer. The

resulting subtrench shall be backfilled with pipe bedding material and shall be compacted, by mechanical means, to a relative compaction of ninety percent (90%) and shall be true to the designed line and grade for the normal trench bottom.

When excavating for pipes, conduits, ducts, or lines of any kind and a firm foundation is not encountered due to soft, spongy, or other unsuitable material, additional material shall be removed below the normal trench bottom to a minimum depth of one foot (1') or as directed by the City Engineer. The resulting subtrench shall be backfilled with one and one-half to two and one-half inch (1-1/2" to 2-1/2") rock, the size of which is to be selected by the City Engineer and shall be true to the designed line and grade.

Unless otherwise provided in the Special Provisions, any additional bedding material ordered over the amount required above shall be paid for in accordance with Section 4-1.03D, "Extra Work". If the necessity for such additional bedding material has been caused by an act or failure to act on the part of the Contractor, or is required for the control of ground water, the Contractor at his/her expense shall provide the additional excavation and bedding material.

**19-4.022 Trench Backfill** - After the pipe, conduit, duct, line, or the various plastic pipe in Section 71 of these Standard Specifications, hereinafter called pipe, except for cast-in-place concrete pipe, has been properly laid, bedded, and approved, material meeting the following Specifications for initial backfill shall be deposited by hand to the springline of the pipe, and in such a manner as to prevent disturbing the pipe or altering its line or grade. Said initial backfill material shall be thoroughly compacted by mechanical means in combination with jetting to obtain a density of ninety-five percent (95%) relative compaction. This backfill material shall be placed in horizontal uniform layers and shall be brought up uniformly on all sides of the pipe.

Initial backfill material shall then be placed in uniform layers on all sides of the pipe to a level at least twelve inches (12") above the top of the pipe. Said initial backfill material shall be compacted by mechanical means in combination with jetting to obtain a relative compaction of ninety-five percent (95%).

The trench, from a depth of twelve inches (12") over the top of the pipe to the bottom of the structural section of the pavement, as shown on Standard Plan 16, shall be backfilled with material conforming to the following specification for intermediate backfill. The Contractor at his/her expense may use initial backfill material in lieu of intermediate backfill.

Intermediate backfill shall be placed in such a manner as to prevent disturbing the pipe or altering its line or grade and shall be thoroughly compacted to a relative compaction of ninety-five percent (95%).

When heavy machinery tamping of backfill material is employed, uniform layer thickness of backfill material shall be as stipulated by the manufacturer of such equipment to produce the relative compaction specified.

Jetting of intermediate backfill that meets the grading requirements for initial backfill material as specified in Section 19-4.022a shall be allowed unless otherwise specified in the Special Provisions or shown on the Plans. Horizontal layers shall not exceed four feet (4') in depth and no jetting shall be allowed on the upper forty inches (40") of trench.

Jetting shall be accomplished only by inserting the water pipe, equipped with an approved

jetting head, to the lowest portion of the fill to be compacted, and continuously running water until the water rises to the surface. Insertion of jet pipes shall be at four foot (4') maximum intervals.

Trenches too narrow for mechanical compaction shall be backfilled and compacted with cement slurry in accordance with Section 19-3.062.

**19-4.022A Backfill Material** - Backfill materials shall be clean and free from decomposed materials, vegetable matter, and other deleterious substances. Bedding material, initial backfill, and intermediate backfills all consist of material which conforms to the following grading requirements:

**BACKFILL GRADING REQUIREMENTS  
PERCENTAGE PASSING**

Sieve Sizes	Bedding Material	Initial Backfill	Intermediate Backfill
3 inches	-----	-----	100
2-1/2 inches	-----	-----	90-100
1-1/2 inches	-----	-----	-----
1 inch	100	-----	-----
3/4 inch	65-90	100	-----
1/2 inch	30-45	90-100	-----
3/8 inch	5-25	-----	-----
#4	0-10	35-100	35-100
#200	-----	0-10	-----

Initial backfill material shall have a sand equivalent of not less than thirty (30) as determined by test method California 217.

Intermediate backfill material shall be non-plastic, shall not be designated in the CH or MH soils classification as determined by ASTM Test D-4319-00 and shall have a sand equivalent of not less than twenty (20).

At the option of the Contractor and at his/her expense, slurry cement backfill in accordance with Section 19-3.062 may be used in lieu of initial and/or intermediate backfill.

**19-4.022B Backfill for Cast-In-Place Concrete Pipe** - Initial backfill material shall be placed to twelve inches (12") over the top of the pipe. Depth of backfill over the top of pipe shall not exceed six inches (6") until concrete compressive strength has reached seven hundred psi (700 psi) and pipe has been in place twenty-four (24) hours. Backfill may be completed when concrete strength reaches one thousand psi (1000 psi) and pipe has been in place forty-eight hours (48 hrs). No backfill other than an initial six inches (6") layer may be placed until the specified compressive strength is attained and permission in writing has been obtained from the City Engineer. All other backfill methods and materials and requirements shall be as specified above.

**19-4.023 Trench Requirements** - Unless permanent pavement is placed immediately, temporary bituminous surfacing two inches (2") thick shall be placed and maintained at

locations determined by the City Engineer wherever excavation is made through pavement, sidewalk, or driveways.

**19-4.03 Trenches in Unimproved Areas** - Trenches in unimproved areas shall be considered any trench in an area not considered an improved area under Section 19-4.02 or any area as defined in Section 19-4.04, "*Subdivisions and Unimproved Streets.*"

**19-4.031 Trench Excavation** - In all areas used for farming purposes or when designed on the Plans or in the Special Provisions, the existing topsoil shall be removed to a depth of two feet (2'), for the entire width of the excavated area, and stockpiled for subsequent replacement. The removed topsoil shall be protected and preserved from mixture with other soils and deleterious substances until it is replaced to its former location. All other conditions shall be as specified in Section 19-4.021.

**19-4.032 Trench Backfill** - After the pipe, conduit, duct, line, or the various plastic pipe in Section 71 of these Standard Specifications, hereinafter called pipe, except for cast-in-place concrete pipe, has been properly laid and approved, material meeting the specification for bedding material, as shown in Section 19-4.022a, shall be deposited by hand as shown on Standard Plan No. 16. Initial backfill material shall be thoroughly compacted by mechanical means in combination with jetting to obtain a density of ninety-five percent (95%) relative compaction. Initial backfill material shall then be placed in uniform layers on all sides of the pipe to a level at least twelve inches (12") above the top of the pipe. Said initial backfill material shall be compacted by mechanical means or jetting to a relative compaction of ninety-five percent (95%).

The trench, from twelve inches (12") over the top of the pipe to an even plane two feet (2') below final finished grade, may be backfilled with native material from excavation, free from stones or lumps exceeding three inches (3") in greatest diameter, vegetable matter, other unsatisfactory material and shall be compacted to a relative compaction of eighty-five percent (85%) or to a density equal to that of surrounding soils, whichever is more.

Compaction of trench backfill by jetting shall be permitted to a point twenty-four inches (24") below finished grade except when, as determined by the City Engineer, the backfill material is of such character that it shall not be self-draining when compacted. Ponding shall not be permitted.

When jetting is permitted, material for use as trench backfill shall be placed and compacted in layers not exceeding four feet (4') in thickness. The work shall be performed without damage to the pipe and embankment and in such a manner that water shall not be ponding. Jetting methods shall be supplemented by the use of other compaction equipment when necessary to obtain the required compaction. Water used for jetting shall be furnished and applied by the Contractor at his/her expense.

Jetting shall be accomplished only by inserting the water pipe, equipped with an approved jetting head, to the lowest portion of the fill to be compacted, and continuously running water until the water rises to the surface. Insertion of jet pipes shall be at four foot (4') maximum intervals.

When heavy machine tamping of backfill material is employed, layer thickness of backfill material may be modified to depths stipulated by the manufacturer of such equipment to produce the relative compaction specified. Such equipment shall be equipped with impact

regulator valves which shall permit the rams to strike more gently blows against the first course of material and as otherwise required.

**19-4.032A Backfill for Cast-In-Place Concrete Pipe** - Initial backfill material in accordance with Section 19-4.02a, "*Backfill Material*" shall be placed by hand to a depth of 12 inches over the top of the pipe.

Said initial backfill material shall be thoroughly compacted by tamping or jettling to obtain a density of ninety-five percent (95%) relative compaction. Intermediate backfill material may consist of native material from excavation, free from stones or lumps exceeding three inches (3") in greatest diameter, vegetable matter, or other unsatisfactory material. In accordance with the curing procedures specified in Section six inches (6") uniform layer of moist, loose initial backfill material may be placed on the pipe, by hand, as soon as possible after pipe placement without damage to the pipe.

Depth of backfill over the top of pipe shall not exceed six inches (6") until concrete compressive strength reaches seven hundred psi (700 psi) and pipe has been in place twenty-four hours (24 hrs). Backfill may be completed when concrete strength reaches one thousand psi (1000 psi) and pipe has been in place forty-eight hours (48 hrs). No backfill other than the six inches (6") layer permitted for curing purposes shall be placed until the tests designated have been made and permission in writing has been obtained from the City Engineer.

Backfill material shall be compacted to a density equal to that of the surrounding soils or to a relative compaction of eighty-five percent (85%), whichever is less except in improved areas.

**19-4.04 Subdivision and Unimproved Streets** - Trenching in subdivisions and unimproved streets shall be considered any area which shall be improved and the improvements shall be accepted by the City and shall become part of the public property or right-of-way.

**19-4.041 Trench Excavation** - Shall be as specified in Section 19-4.021 of these Specifications.

**19-4.042 Trench Backfill** - Shall be as specified in Section 19-4.032 of these Specifications except as herein modified.

The trench, from one foot (1') over the top of the pipe to the bottom of the structural section may be filled with native material from the excavation, free from stones, or lumps exceeding three inches (3") in diameter, vegetable matter, or other unsatisfactory material, and shall be compacted to a relative compaction of ninety-five percent (95%).

**19-4.05 Payment** - Payment for trench excavation and backfill and addition of water for any reason are considered to be included in the payment for the pipe and no additional compensation shall be allowed therefore.

A Proposal item may be included for removal of unsuitable material and imported select material to be paid for on a cubic yard basis. Such payment shall include the necessary excavation and select material in place and the City shall have the right to increase or decrease the Proposal quantity by more than twenty-five percent (25%) with no adjustment of the Contract unit price.

**19-4.06 Ditch Excavation** - Ditch excavation shall consist of excavating ditches within or outside the right-of-way, including channels for changing the course of streams, all as shown on the Plans or Specifications.

The excavation required constructing a ditch or channel designated with a bottom width of less than thirteen feet (13') would be classed as ditch excavation.

The excavation required to construct a ditch or channel designated with a bottom width of thirteen feet (13') or more shall be classed as roadway excavation.

Material resulting from excavating ditches or channels shall be used to construct roadway embankments, dikes, or other purposes, or disposed of, unless directed otherwise by the City Engineer.

Care shall be exercised to prevent excavating below the grade for the bottom of the ditch or water channel, and areas excavated below grade shall be filled with suitable material and thoroughly compacted in accordance with Section 19-5.03 by the Contractor at his/her expense.

**19-4.061 Measurement** - Quantities of ditch excavation to be paid for shall be computed by means of average areas and the distances between these areas.

**19-4.062 Payment** - The excavation of ditches and channels which have a bottom width of less than thirteen feet (13'), gutters within the median area of a divided highway, gutters between the roadbed shoulder and an adjacent excavation slope, gutters in excavation benches, and side gutters contiguous to embankment slopes, all as shown on the Plans, shall be paid for as roadway excavation. If no roadway excavation item is provided in the Contract, full compensation for this work shall be considered as included in the other items of work and no further compensation shall be allowed therefore.

The above price and payments shall include full compensation for furnishing all labor, materials, tools, equipment, and incidentals, and for doing all the work involved in excavating ditches completely, as shown on the Plans, and as specified in these Specifications and the Special Provisions.

## SECTION 20

### LANDSCAPE AND IRRIGATION

All work shall meet the requirements of the Grading Standards, and the most current edition of "The City of Salinas Storm Water Development Standards for New Development and Significant Redevelopment Projects" which can be found on the City's webpage [www.ci.salinas.ca.us](http://www.ci.salinas.ca.us) or copies may be obtained at Development and Engineering.

Landscaping, functional planting and irrigation shall be as specified herein in lieu of the State Standard Specifications.

#### 20-1. General

This Section shall govern the preparation, planting, and irrigation system construction for landscaping areas required by the Plans or Special Provisions.

Existing utilities and improvements not designated for removal or relocation shall be protected in place. Removals shall be performed in accordance with applicable provisions of Section 8 of the State Standard Specifications. Use of existing City utility services is permitted upon approval of cost reimbursement.

Cost of temporary utility services, metering and its removal that is necessary to complete the work required by the Plans and/or Specifications shall be borne by the Contractor.

Cost of new utility services and its metering that is necessary to complete the work required by the Plans and Specifications shall be borne by the Contractor until the Project is accepted, relief from maintenance and responsibility granted, or when the Plant Establishment period ends.

Unless otherwise provided, walls, curbs, planter boxes, walks, irrigation system, and similar improvements required by the Plans and/or Special Provisions shall be constructed following rough grading and before landscaping.

## **20-2. Landscape Materials**

**20-2.01 Topsoil** - Topsoil shall be designated as Class A (imported), Class B (selected), or Class C (unclassified) as specified herein. The City Engineer shall determine the suitability of topsoil prior to use. Topsoil shall be transported from the source to its final position unless stockpiling is specified.

**20-2.011 Class "A" Topsoil** - Class "A" topsoil shall be from a source outside the limits of the project selected by the Contractor and in compliance with the requirements specified herein. The City Engineer may make such inspections and perform such tests as deemed necessary to determine that the material meets the requirements.

At least fifteen (15) calendar days before scheduled use, the proposed source of topsoil must be submitted to the City Engineer for approval. The Contractor shall submit a written request for approval, which shall be accompanied by a written report of a testing agency registered by the State for agricultural soil evaluation, which states that the proposed source complies with these Specifications. Class "A" topsoil shall have the same relative composition and structure, a friable sandy loam character, and be free of roots, clods, and stones larger than one inch (1") in greatest dimension, pockets of coarse sand, noxious weeds, sticks, brush, and other litter. It shall not be infested with nematodes or other undesirable insects and plant disease organisms. Class "A" topsoil shall meet the following additional requirements:

**20-2.011a Gradation Limits** – Sand shall be fifty to eighty percent (50%-80%), clay shall be twenty percent (20%) maximum, and silt shall be thirty percent (30%) maximum. The sand, clay, and silt gradation limits shall be as defined in ASTM D-422.

**20-2.011b Permeability Rate** - Not less than one-half inch (0.5") per hour nor more than two inches (2") per hour when tested in accordance with ASTM D-2434, Calif. Test 220 or other approved methods.

**20-2.011c Agricultural Suitability** - The topsoil shall be suitable to sustain the growth of the plants specified.

**20-2.012 Class "B" Topsoil** - Class "B" topsoil is defined as material which is obtained from sources and in the quantities designated on the Plans or in the Specifications and which

requires transport to the designated landscape areas. Such designated sources of the Class B topsoil may be within or outside the project limits. The cost of stripping the surface of vegetation and debris at the designated locations and processing of the material to a finely divided state, before it is spread, shall be included in the price bid for hauling and placing.

**20-2.013 Class “C” Topsoil** - Class C topsoil is defined as soil found in place in the designated landscape area, including soil compacted in place as part of the earthwork specified for the project.

**20-2.02 Soil Fertilizing and Conditioning Materials** - Fertilizing materials shall comply with the applicable requirements of the State Food and Agricultural Code. All fertilizing materials shall be packaged first grade, commercial quality products identified as to source, type of material, weight and manufacturer’s guaranteed analysis. Fertilizing material shall not contain toxic ingredients or fillers in quantities harmful to human life, animals, or plants.

When required by the City Engineer, the Contractor shall furnish a Certificate of Compliance stating that the material substantially meets the specifications

**20-2.021 Commercial Fertilizer** - Commercial fertilizer shall be a palletized or granular product having a chemical analysis as specified on the Plans or in the Specifications. Commercial fertilizer shall be free-flowing material delivered in unopened sacks. Material that becomes caked or otherwise damaged shall not be used.

**20-2.022 Organic Soil Amendment** - Soil testing needs to be completed before amendments are incorporated into the project soils. The results of a certified laboratory soil test shall identify the deficiencies in the soil. The soil test shall specify the amendments and volumes to be added to the project soils. Amendments lacking in the soil shall be added per the recommendation of the certified laboratory soil test.

Organic soil amendment shall be selected from Type 1 or 2 products as described herein.

Type 1 organic soil amendment shall be a ground or processed wood product derived from redwood, fir, or cedar sawdust, or from the bark of fir, or pine, treated with a non-toxic agent to absorb water quickly, and shall comply with the following requirements:

<b>GRADATION: SIEVE SIZE</b>	<b>PERCENT PASSING</b>
1/4 inches	95% minimum
#8	80% minimum
#35	30% minimum
 <b>NITROGEN CONTENT (% DRY WEIGHT)</b>	
Redwood	0.4% - 0.6%
Fir	0.56% - 0.84%
Cedar	0.56% - 0.84%
Fir bark	0.8% - 1.2%
Pine bark	0.8% - 1.2%



## SALINITY

Maximum saturation extract conductivity: 6.35 milliomhs/inch at 77°F.

## WETTABILITY

When 0.393 cubic inches of tap water is applied to one teaspoon of tap water is applied to 4 cubic inches (volumetric ratio of 1:15) of the air-dry product, the material shall become completely damp in a period not exceeding two (2) minutes. Any wetting agent added shall be guaranteed non-photo-toxic at the rate used.

Type 2 organic soil amendments shall be a relatively dry friable or granular composite derived from sewage sludge processed for agricultural use. It shall contain at least one percent (1%) nitrogen by dry weight and comply substantially with the gradation for Type 1 soil amendment.

**20-2.023 Mulch** - It is not to be placed immediately at the base of plants. When mulch is added to planted beds, the mulch shall be placed outside the drip line of planted material. Do not install mulch within six inches (6") of tree trunks.

Mulch shall be designated by Type in accordance with the requirements herein. Mulch shall be packaged in bales or bags unless the City Engineer approves a bulk source in advance of delivery to the site of the work:

*Type 1* mulch (ground wood product), shall comply with the requirements for Type 1 organic soil amendment.

*Type 2* mulch (sewage sludge product), shall comply with the requirements for Type 2 organic soil amendment.

*Type 3* mulch (peat), shall be brown compressed sphagnum or hypnum.

*Type 4* mulch (fir bark chips), shall be fir bark chips in the gradation specified.

*Type 5* mulch (straw), shall be either threshed new straw or stable bedding material derived from rice, oats, or barley. Straw in an advanced state of decomposition shall not be acceptable.

**20-2.03 Seed** - Seed shall be fresh, clean, new crop seed, mechanically premixed to specified proportions.

Seeds shall be delivered to the site in original unopened containers bearing the dealer's guaranteed analysis and germination percentage, and a certificate or stamp or release by a County agriculture commissioner. Any seed tagged "warning, hold for inspection" shall be inspected and released by the agriculture commissioner of the County within which the seeds are to be planted.

**20-2.04 Plants** - Unless otherwise specified in the Special Provisions, plants shall be inspected and approved at the nursery by the City Engineer prior to shipment to the planting site. The Contractor at his/her expense shall arrange for the necessary inspection. The City Engineer prior to planting shall also inspect all plants at the planting site.

All plants shall have a growth habit normal to the species and shall be sound, healthy, vigorous, and free from insect pests, plant diseases, sunscalds, fresh bark abrasions, excessive abrasions, or other objectionable disfigurements. Tree trunks shall be sturdy and well “hardened off”. All plants shall have normal well-developed branch systems, and vigorous and fibrous root systems which are neither root nor pot-bound and are free of kinked or girdling roots.

Other than the normal side pruning during the growth period, no pruning shall be done prior to inspection at the nursery

**20-2.041 Trees** - Unless otherwise specified in the Special Provisions, trees shall be inspected and approved at the nursery by the City Engineer prior to shipment to the planting site. The Contractor at his/her expense shall arrange for the necessary inspection. Nursery stocks shall be in accordance with Urban Tree Foundation “Guideline Specifications for Nursery Tree Quality” which can be found on the website: <http://urbantree.org/specs.asp>. All trees shall be of the specified height and crown to the last division of the terminal leader and diameter. The height shall be measured from the root crown. The diameter shall be measured six inches (6”) above the root crown. The height of palm trees shall be measured from the groundline to the base of the fronds except in the case of Canary type, which shall be measured to the bottom of the “pineapple”. The trees shall stand reasonably erect without support.

**20-2.042 Shrubs** - Shrubs shall be of the specified type and size, selected from high quality well-shaped nursery stock.

**20-2.043 Prostrate Growing Plants** - Ground cover plants and other prostrate growing plants shall be well grown and remain in the flats until transplanted at the site. The soil and spacing of the plants in the flat shall insure the minimum disturbance of the root system at time of transplanting.

**20-2.044 Sod and Stolons (turf grass)** - Unless otherwise specified in the Special Provisions, turf grass sods shall be fresh, clean, living sections of runners of hybrid grass. Replacement sod shall match the existing grass that was removed. Sod shall be free of turf disease, insects, or weeds, and capable of healthy vigorous growth and shall be approved by the City Engineer prior to placement. Sod shall be placed in accordance with Section 20-4.082. Nursery sod production shall be in accordance with the Nursery Sod Growers Association of Ontario (NSGA) website: <http://www.gov.on.ca/OMAFRA/english/crops/facts/top>

For mechanical or hand spreading, turf grass stolons shall be one to four inches (1” to 4”) long and bent grass four to eight inches (4” to 8”) long. Stolons to be planted in a slurry mixture as described in Section 20-4.083 shall be supplied in shorter sections as required.

**20-2.045 Cuttings** - Cuttings shall be fresh stock cut with a sharp hand tool from the stems of the healthy vigorous plants of the species specified. If not otherwise specified, the length of cuttings shall be in accordance with the best horticultural practice.

**20-2.05 Headers, Stakes and Ties** - Lumber for landscape work shall be construction heart rough redwood in the sizes specified. Galvanized steel pipe shall be as specified in Section 20-3.011. Nails, lag screws, and miscellaneous hardware shall be “hot dipped” galvanized commercial quality material. Miscellaneous fabricated metal items shall be made from steel conforming to ASTM A-36.

**20-2.051 Headers and Stakes** - Headers shall be two inches (2") x four inches (4") except that two (2) one inch (1") x four inches (4") boards shall be supplied for laminations on turns and curves. Header stock shall be supplied in lengths at least ten feet (10'). Stakes for headers shall be pointed two inches (2") x four inches (4"), at least eighteen inches (18") long. Joint splicing lumber shall be one inch (1") x four inches (4"), two feet (2') long.

**20-2.052 Tree Stakes** - The type of tree stakes shall be as designated in the Special Provisions. The length of tree support stakes shall be ten feet (10').

Guy ties shall be reinforced rubber tire tree straps twenty-four inches (24") long and one inch (1") wide. Plastic ribbon tie material shall be one inch wide with a minimum tensile strength of five hundred pounds (500 lbs).

Deadman stakes shall be either two inches (2") x four inches (4") redwood or three-quarter inch (3/4") diameter steel pipe three feet (3') long.

### **20-3. Irrigation System Materials**

**20-3.01 Pipe and Fittings** - The type of pipe materials and fittings shall be as designated on the Plans or in the Special Provisions and shall comply with the following:

**20-3.011 Steel Pipe** - Steel pipes shall be galvanized, standard weight (Schedule 40) complying with the requirements of ASTM A -120. Steel pipes shall be jointed with galvanized, threaded, standard weight malleable iron fittings and couplings.

**20-3.012 Plastic Pipe for use with Solvent Weld Socket or Threaded Fittings** - Plastic pipes shall be rigid unplasticized polyvinyl chloride PVC 1220. (Type 1, Grade 2), conforming to ASTM D-1785. Plastic pipe marked with product standard PS-21-70 conforms to the ASTM requirements. The minimum pressure rating shall not be less than the working pressures indicated therein for the schedule and sizes listed.

Schedule 40 pipes shall be used for installation on the discharge side of control valves and Schedule 80 pipes shall be used for continuously pressurized pipe on the supply side of control valves. Schedule 80, only, shall be supplied when threaded joints are specified or otherwise permitted by the City Engineer.

Fittings and couplings for plastic pipe shall be threaded or slip-fitting tapered socket solvent weld type. Threaded adapters shall be provided with socket pipe for connections to threaded pipe. Plastic pipe fittings and couplings shall be PVC I or PVC I/II material supplied in the same schedule size specified for the pipe. The type of plastic material and schedule size shall be indicated on each fitting or coupling. Fittings and couplings shall comply with the following specifications:

#### **SOCKET FITTINGS**

Schedule 40	ASTM D-2466
Schedule 80	ASTM D-2464

## THREADED FITTINGS

Schedule 80

ASTM D-2464

**20-3.013 Plastic Pipe for use with Rubber Ring Gaskets** - Plastic pipe for use with rubber ring gaskets shall be rigid unplasticized polyvinyl chloride PVC 1120 (Type 1, Grade 1), manufactured in accordance with ASTM D-2241. Plastic pipe marked with product standard PS 22-70 conforms to the ASTM requirements. Pipe shall be supplied with plain ends or with an integral thickened expanded bell with rubber ring groove. Couplings for plain end pipe shall be of the single rubber ring type with solvent weld socket on one end or shall be of the double rubber ring type.

Rubber ring gaskets shall be of a synthetic rubber supplied in accordance with the requirements of ASTM D-1869.

Pipe shall be furnished in the following Standard Dimension Ratios (SDR) and Pressure Ratings:

160 psi	SDR 26
200 psi	SDR 21

**20-3.014 Copper Pipe** - Copper pipe shall be Type K in accordance with ASTM B-88M (ASTM B-88). Copper pipe shall be jointed with the appropriate solder type wrought copper fittings for two and one-half inches (2-1/2") and smaller sizes. Cast brass fittings shall be used for sizes over two and one-half inches (2-1/2").

**20-3.02 Valves and Valve Boxes** - Valves shall be of the size, type, and capacity designed on the Plans or in the Special Provisions and shall comply with the requirements specified herein.

All valves except garden valves shall be capable of satisfactory performance at a working pressure of two hundred psi (200 psi). Valves shall be designed to permit disassembly to replace sealing components without removal of the valve body from the pipeline. All valves shall be fully ported to match the size of its inlet pipeline.

**20-3.021 Gate and Ball Valves** - Gate valves in sizes two inches (2") and smaller shall be all bronze double disc wedge type with integral taper seats and non-rising stem. Sizes two and one-half inches (2-1/2") and larger shall be iron body, brass trimmed with other features the same as for two inches (2"). Ball Valves need to be installed on pipe sizes up to three inches (3"). When ball valve is installed, the handle needs to be parallel to the side of pipe. When the valve is shut off the handle should be facing straight up. Gate valves need to be resilient seated

**20-3.022 Manual Control Valves** - Manual control valves shall be brass or bronze, and shall be straight or angle pattern globe valves, full opening, key operated with replaceable compression disc and ground joint union on the discharge end. Unions shall be installed on both sides of manual control valves.

**20-3.023 Remote Control Valves** - Remote control valves shall be electrically or hydraulically operated. They shall be brass, bronze, or plastic body with accurately machined valve seat surfaces, equipped with flow control adjustment and capability for manual operation. They shall be made so that they may be readily disassembled for servicing.

Unions shall be installed on both sides of remote control valves. Install ball valve before valve and unions (inflow side).

**20-3.024 Garden Valves** - Garden valves shall be brass or bronze except for the handle. They shall have a replaceable compression disc, and shall be three-quarter inch (3/4") straight-nosed, key operated and pressure rated for operation at one hundred and fifty psi (150 psi).

**20-3.025 Quick-Coupling Valves and Assemblies** - Quick-coupling valves shall be brass or bronze with built-in flow control and self-closing valve and supplied in one inch (1") size unless otherwise required. When a quick-coupler assembly is specified, it shall consist of the valve, quick coupler connection and hose swivel. All quick-coupling valves and assemblies shall be installed with a Schedule 80 triple swing joint.

**20-3.025A Master Valve and a flow meter in all irrigation systems** - Install a Master Valve and a flow meter in all irrigation systems. The master valve and flow meter should be installed within twenty feet (20') of backflow. The master valve needs to be installed in a valve box that meets City Standards. The flow meter should meet the Data Industrial 200 series Plastic Tee Type Meter (Model 220PV) standard or industry equal. It should include the "IR" sensor not the standard sensor. The wire for the flow meter needs to be installed in conduit from the controller to the flow meter. A valve box needs to be installed over the flow meter that meets City Standards. The wires need to be at least two (2) conduit- ICEA, Class "B" sixteen gauge-2/C (16 ga.-2/C), seven (7) strand. The pressure for the flow meter needs to be set at 15 gpm higher than the highest gpm in the irrigation system design.

**20-3.026 Valve Boxes** - Valve boxes and covers shall be precast Portland cement concrete sized as necessary and in accordance with the "Dimension Tables" in Caltrans Standard Plan ES-8 with precast concrete cover marked "WATER" in cast-in letters not less than one inch (1") high. The box shall be set to finished grade on a six inches (6") layer of three-quarter inch (3/4") crushed rock. A continuous piece of one-quarter inch (1/4") to one-half inch (1/2") mesh, nineteen gauge (19 ga.) minimum galvanized woven wire cloth shall be between the box and crushed rock.

Valve boxes need to be installed twelve inches (12") from all walkways, curbs, header boards, buildings, and soundwalls. There needs to be a twelve inch (12") separation between valve boxes when more than one is required.

Irrigation valve box covers need to have controller identification and valve number identification permanently inscribed on top of lid.

Valve box and cover for remote control valves may be plastic as manufactured by Carson-Brooks, National Diversified Sales (NDS), or approved equal by the City Engineer.

All rectangle irrigation valve boxes shall have four (4) bricks installed under each corner. Round valve boxes shall have two (2) bricks installed.

Valve boxes installed in raised median islands or any areas affected by vehicle traffic, shall use Christy B1017H/20 Traffic Box per Caltrans No. 3-1/2T State Standard Specifications.

**20-3.03 Backflow Preventer Assembly** - The backflow preventer assembly shall consist of a backflow preventer unit and related components conforming to the governing code requirements.

Its assemblies need to be tested by a licensed and Certified Backflow Tester before final acceptance shall be given. It shall be one of the approved reduced pressure principle devices listed by the California Department of Health Services, Division of Drinking Water and Environmental Management, 601 North 7th Street, Mailing Station (MS) 92, P.O. Box 942732, Sacramento, CA 94234-7320.

Backflow Preventer Assembly needs to have ball type test cocks with covers installed to allow for standard backflow tester unit equipment connection on all four (4) test cocks. All its assemblies need to have an insulated aluminum or stainless steel cover installed over them.

Install Y-strainer with twenty (20) mesh filter on the inflow side before all backflow preventer assemblies.

Install ball valve or gate valve depending on pipe size of the inflow side before all backflow preventer assemblies. For PVC shut-off, ball valve shall be installed in the ground within several meters [feet] of the backflow preventer assembly, a valve box installed over it per City standards.

Backflow preventer shall be factory assembled and shall include two (2) check valves, one pressure differential relief valve, two (2) shut-off valves and four (4) test cocks. Backflow preventer and valves shall be the same size as the pipeline in which they are installed, unless otherwise shown on the Plans.

Backflow preventer shut-off valves shall be manufactured from iron or bronze and shall be resilient seated and fully ported ball valves. Threaded type shut-off valves shall be with a union on one side of each valve. Unions shall be brass or malleable iron.

Backflow cage shall be factory insulated made of stainless steel. Backflow blankets shall not be accepted as insulation. The backflow cage shall include an ability to be locked to the concrete pad.

The backflow cage pad shall consist of: six inches (6") thick Class "B" concrete pad for enclosure support and shall extend six inches (6") beyond enclosure on all sides. Concrete pad shall have a brushed finish. All forms are to be removed before completion of project.

**20-3.04 Sprinkler Equipment** - Sprinkler heads, bubbler heads, and spray nozzles shall be of the types and sizes shown on the Plans. Such equipment shall be brass, bronze, and stainless steel, except for minor components. Equipment of one type and flow characteristic shall be from the same manufacturer and all equipment shall bear the manufacture's name and identification code in a position where they can be identified in the installed position.

All pop-ups and rotary heads used in planted areas need to be installed to final grade and "NOT" flush to the curb or sidewalk. All irrigation heads need to be installed perpendicular to final grade. All irrigation heads need to be installed with Schedule 80, triple swing joints (preassembled Schedule 80 swing joints are okay).

Fixed heads sprinklers shall have a one-piece housing with provision for interior parts replacement. Pop-up sprinklers shall be designed to rise at least four inches (4") during operation. Full or part circle sprinklers shall be interchangeable in the same housing.

All sprinkler heads shall have an in-stem pressure regulator that shall maintain a constant pressure of thirty psi (30 psi) and reduce water loss by sixty percent (60%) should the nozzle be removed or damaged. All sprinkler heads shall have an in-stem check valve that shall hold a minimum five psi (5 psi) of head to prevent leakage upon shutoff.

Shrubbery and bubbler heads shall be adjustable from full flow to shut off.

**20-3.05 Electrical Materials** - The Contractor shall furnish and install all electrical equipment and materials required for a complete electrical system. All equipment and materials shall comply with the requirements of the governing code and the serving utility and shall be approved and identified by Underwriters Laboratories, Inc. (UL).

**20-3.051 Conduit** - Conduit above ground and within buildings shall be galvanized steel conforming to the applicable provisions of Section 86-2.05 or as specified in the Special Provisions. Conduits below ground and direct burial may be schedule 40 PVC and contain a minimum number twelve (#12) grounded bare copper conductor.

**20-3.052 Conductors** - Line voltage conductors shall be supplied in the sizes and types shown on the Plans and shall be THW or THWN, six hundred (600) volt insulation rating, conforming to the applicable provisions to ASTM D-2219 and D-2220.

Low voltage control conductors shall be Type UF and supplied in the sizes shown on the Plans or in accordance with the control equipment manufacturer's recommendation, and shall be UL approved for direct burial installation.

**20-3.053 Controller Unit** - The type of control unit shall be as called for on the Plans. It shall be fully automatic, with provisions for manual operation, sized to accommodate the number of stations or control valves included in the system. Outdoor models shall be housed in a vandal-proof and weatherproof enclosure with locking cover.

All irrigation controllers shall have a telephone wire installed in conduit from controller box to phone source. The controller is not required to have a modem installed. The wire shall be installed for future use.

A permanent receiver card shall be installed in each controller. This shall allow the controller to be operated from several miles away.

**20-3.054 Pull Boxes** - Pull boxes shall be No. 5 in accordance with the "Dimension Tables" in Caltrans Standard Plan ES-8 or larger unless otherwise shown on the Plans and shall conform to the Provisions in Section 86-2.0A, "Materials." Pull box covers for pull boxes used solely for electrical service shall be marked in accordance with the Provisions in Section 86-2.0B, "Cover Marking." All other irrigation system pull box covers shall be marked "SPRINKLER CONTROL" in accordance with the Provisions in said Section 86-2.0B. The pullbox shall be set to finished grade on a six inches (6") layer of three-quarter inch (3/4") crushed rock. A continuous piece of one-quarter inch (1/4") to one-half inch (1/2") mesh, nineteen gauge (19 ga.) minimum galvanized woven wire cloth shall be between the pullbox and crushed rock.

## **20-4. Landscape and Irrigation Installation**

The Contractor shall construct the complete landscape and irrigation work specified.

All work on the irrigation system, including hydrostatic, and coverage tests, preliminary operational tests of the automatic control system, and the backfill and densification of trenches and other excavations shall be performed after topsoil work and before planting.

**20-4.01 Earthwork and Topsoil Placement** - Earthwork and topsoil placement shall include excavation and backfill for the irrigation system and the preparation for and the spreading, densification, cultivation, and raking of topsoil, including fertilization and conditioning. Planting holes and backfill shall be accomplished in accordance with Section 20-4.05, "*Planting.*"

Preliminary rough grading and related work to prepare areas for landscaping work to within one tenth foot (0.1') of finished grade, or to subgrade for Class A or Class B topsoil, shall be completed in accordance with Section 19, "*Earthwork.*"

**20-4.02 Trench Excavation and Backfill** - Trench excavation and backfill shall be in accordance with the Section 19-4 of these Standard Specifications.

Trenches and other excavations shall be sized to accommodate the irrigation system components, conduit, and other required facilities. Additional space shall be provided to assure proper installation and access for inspection. Unless otherwise specified, the minimum depth of cover over pipelines and conduits shall be as follows:

1. Electrical conduit – eighteen inches (18"). Thirty inches (30") under roadways.
2. Water lines continuously pressurized – twenty-four inches (24"). Thirty-six inches (36") under roadways.
3. Lateral sprinkler lines – eighteen inches (18").

The bottom of trenches shall be true to grade and free of protruding stones, roots or other matter, which would prevent proper bedding of pipe or other facilities.

Trenches and excavations shall be backfilled so that the specified thickness of topsoil is restored to the upper part of the trench.

**20-4.03 Topsoil Preparation and Conditioning** - The type and thickness of topsoil shall be as shown on the Plans, or if not shown shall be Class A, six inches (6") thick. Planting areas shall be free of weeds and other extraneous materials to a depth of twelve inches (12") below finished grade before topsoil is spread.

Soil shall not be worked when it is so wet or so dry as to cause excessive compaction or the forming of hard clods or dust.

The existing soil below subgrade for Class "A" topsoil shall be scarified to a depth of six inches (6") prior to spreading topsoil.

Class C topsoil shall be scarified and cultivated to finely divided condition to a depth of eight inches (8") minimum below finished grade. During this operation, all stones over one inch in greatest dimension shall be removed.



**20-4.031 Fertilizing and Conditioning Procedures** - The planting area shall be brought to finished grade before spreading the fertilizers or conditioning materials specified. Fertilizing and conditioning materials shall be mechanically spread at a uniform rate. The quantities of materials necessary for the planting area shall be at the site and shall be verified by delivery tickets furnished to the City Engineer before spreading.

After spreading, the fertilizing and conditioning materials shall be uniformly cultivated into the upper six inches (6") of soil by suitable equipment operated in at least two directions approximately at right angles. The resulting soil shall be in a friable condition.

**20-4.032 Finished Grading** - The finished grade shall be smooth, uniform, and free of abrupt grade changes and depressions to insure surface drainage.

The finished grade below adjacent paving, curbs, or headers shall be one inch (1") in lawn areas and two inches (2") in shrub or ground cover areas.

After fertilizing and conditioning, the soil shall be watered and allowed to settle to provide a stable surface, not overly densified to the extent that it shall prevent aeration and water infiltration. After the soil has dried out to a workable condition, the planting areas shall be regraded, raked, and smoothed to the required grades and contours. Finished surfaces shall be clean and suitable for planting.

**20-4.04 Header Installation** - Headers shall be installed at the location and grades shown on the Plans prior to planting.

Stakes shall be located at splices, corners, and at intervals not to exceed five feet (5') and driven slightly below the top of the header. Splice plates shall be used at butt joints. Headers shall be nailed to stakes with two (2) nails, clinched one-half inch (1/2"). Splice plates shall be centered on the joint and nailed to each header with four (4) 10d box nails.

**20-4.05 Planting** - The types, sizes and quantities of plant materials shall be as called for in the Plans and Specifications.

All plants shall be inspected prior to planting, including plants previously approved at the nursery. The Contractor shall be responsible for the condition of all plants, planted or otherwise, until acceptance from the City.

Planting shall be performed with materials, equipment, and procedures favorable to the optimum growth of the plants and in compliance with these procedures.

Except as noted for specimen planting, all planting shall follow the completion of the irrigation system.

**20-4.051 Protection and Storage** - The Contractor shall keep all plant material delivered to the site in a healthy condition for planting. Plants shall not be allowed to dry out. Bare rootstock shall be separated and "heeled in" in moist earth or other suitable material. Balled and burlapped plants shall have the root ball covered with moist sawdust, wood chips, or other approved material.

**20-4.052 Layout and Plant Location** - Staking for planting areas and detailed layout within the planting areas shall be performed by the Contractor and approved by the City

Engineer prior to planting. Parkway trees shall be located in the field by the Contractor and approved by the City Engineer before planting.

The first row of plants in areas designated for center-to-center spacing of plants shall be located at one-half of designated spacing from the edge of the area.

**20-4.053 Specimen Planting** - Plants in boxes twenty-four inches (24") and larger shall be planted before the installation of lateral irrigation lines.

Irrigation lines conflicting with specimen plant locations shall be re-routed to clear the root ball.

**20-4.054 Tree and Shrub Planting** - Planting holes shall be the depth of the planting container, approximately square with vertical sides twice the width of the plant container or ball, and shall be larger if necessary to permit handling and planting without injury or breakage of the root ball or root system. Any plant with a broken or cracked root ball before or during planting shall not be planted.

Containers shall be opened and removed in such a manner that the plant root is not injured. Balled plant wrappings shall be loosened or cut back after plant is positioned in the planting hole and shall be backfilled and covered with soil mix.

The native soil at the bottom of planting holes shall be scarified to a depth of six inches (6").

No soil amendment is to be added when backfilling any tree or shrub. Native soil shall be used only. Care should be taken not to plant shrubs directly in front of irrigation heads.

After planting, the plant shall be plumb, with the root crown at its natural growing depth with respect to finished grade. Planting shall be governed by the following requirements:

1. A layer of native soil shall be deposited in the planting hole.
2. The plant shall be set approximately at the center of the hole.
3. Native soil shall be deposited in the remainder of the hole to finished grade.
4. The backfill shall be thoroughly water-settled and additional prepared soil mix added to fill any remaining void below finished grade.
5. A circular watering basin slightly larger than the planting hole, four inches (4") high for trees and two inches (2") high for shrubs, shall be left around the plant.
  - a. The bottom of the basin shall be at the approximate finished grade or slightly lower. Type 1, 2, or 3 mulch shall be spread at least two inches (2") thick in the basin.
6. The plants shall be guyed and staked as specified in Section 20-4.06 of these Standard Specifications.
7. The area around the plant shall be regraded to finished grade. The Contractor shall dispose of the excess soil.

**20-4.06 Plant Staking and Guying** - Plant staking and guying shall be installed as follows:

**20-4.061 Tree Staking** - The tree shall be staked with two (2) two inch (2") x ten foot (10') Lodge Pole Pine stakes in accordance with Standard Plan 11. Ties shall be reinforced rubber tire tree straps twenty-four inches (24") long and one inch (1") wide. The loop shall be one inch (1") greater in diameter than the trunk and attached to the lodge pole with a figure eight at the locations as shown on the Standard Plan.

**20-4.062 Guying** - Trees and other plants, except specimen plants, to be guyed shall be designated in the Contract Documents.

Guying shall be done immediately after planting. Three (3) guys per plant shall be installed in accordance with the following:

1. Each guy shall be secured to the appropriate main branch by a twisted loop of No. 12 AWG zinc-coated iron wire housed in garden hose.
2. Each guy shall be anchored to a driven stake located at a horizontal distance from the tree equal to the vertical distance from ground to the connection of guy wire on the tree branch.
3. Each guy shall be covered with highly visible garden hose or plastic tubing to a height of six feet (6') above finished grade.
4. Slack in each guy shall be removed by hand so as not to bend or twist the plant.

**20-4.07 Ground Cover and Vine Planting** - Soil preparation and fine gradings shall be completed prior to ground cover planting.

Ground cover and vines shall be planted in moist soil and spaced as indicated on the Plans.

Each plants shall be planted with its proportionate amount of flat soil to minimize root disturbance. Soil moisture shall be such that the soil does not crumble when removing plants.

Following planting, ground cover and vine areas shall be regraded to restore smooth finished grade and to insure proper surface drainage. A one inch (1") layer of Type 1, 2, or 3 mulch shall be spread over the planted areas. Watering shall begin immediately following mulching.

When necessary to prevent plant damage from pedestrian traffic during the initial growing stage, the Contractor at his/her expense shall erect temporary protective fencing to be removed at the end of the plant establishment period.

Vines shall be tied to walls, fences, etc. in the manner prescribed on the Plans. Temporary staking shall be removed at the end of the plant establishment period.

**20-4.08 Lawn Planting** - Before planting lawn, all specified soil preparation and fine grading shall be completed.

**20-4.081 Seed Lawn Planting** - Seed lawn planting may be accomplished by Method A (dry method) or Method B (hydraulic method). Seeding shall not be performed when the wind velocity exceeds five (5) miles per hour, or is detrimental to the uniform distribution of

the seed.

1. *Method A* - The area to be seeded shall be lightly raked to provide a seedbed.

The required seed mixture shall be sown uniformly at the specified rate. Seeding shall be done in two (2) operations with the spreader set to sow one-half (1/2) the specified amount in each operation. The second sowing shall be at right angles to the first. After sowing, the area shall be rolled and then be evenly covered to a depth of one-quarter inch (1/4") to one-half inch (1/2") with approved mulch.

The lawn area shall be watered in a manner so as not to cause surface erosion. Newly seeded surfaces shall be kept moist continuously throughout the germination period.

2. *Method B* - The seed, fertilizer, fiber and other materials in the slurry mixture shall be as specified. All materials shall be of such character that they shall disperse into uniform slurry when mixed with water. The mixture shall be such that an absorbent porous mat shall be formed.

All materials shall be available for inspection prior to application. Weights and contents of containers shall be clearly identified. A green coloring additive shall be used in the slurry for visual inspection purposes.

The slurry shall be applied under pressure at the specified rates.

Areas to be planted by this method shall be rolled and then moistened to a depth of six inches (6") but shall not be surface wet at the time of application.

The slurry planted areas shall be kept moist during the germination period, but puddling shall be avoided.

**20-4.082 Sod Lawn Planting** - The type and thickness of sod and the areas to be sodded shall be in accordance with the Contract Documents.

Subgrade for sods shall be the specified thickness of the sod below finished grades. Soil conditioning, fine grading, and rolling shall be completed before sodding. No heavy equipment shall operate over the subgrade after grading is completed.

The subgrade shall be moist but not wet when sod is laid. Sod shall be laid with closely fitted joints, and the ends of the strips shall be staggered. Openings shall be plugged with sod or topsoil.

Within two (2) hours after installing sod and before rolling, the sod shall be lightly irrigated. All seams and joints shall then be rolled until the sod is well bonded to the subgrade.

The area shall then be watered thoroughly to penetrate the subsoil at least eight inches (8"). Watering shall be repeated as necessary to keep the sod moist until rooted into the subgrade. Sodded areas shall be protected against foot traffic until the sod is well established.

**20-4.083 Stolon Planting** - Topsoil preparation, conditioning and finished grading shall be completed in accordance with Section 20-4.03 and 20-4.032 before stolon planting.

The area to be planted in stolons shall be thoroughly irrigated to a depth of at least eight inches (8"). As soon as the soil can be worked, the specified commercial fertilizer shall be worked into the top one inch (1") of soil.

At the time of planting, the top two inches (2") of soil shall be friable and contain enough moisture to prevent stolons from drying out during the planting operation. The stolons shall be worked into the soil to a depth of one-half inch (1/2") to one and one-half inches (1-1/2") by a mechanical or hand planter, or broadcast by hand and covered with one-quarter inch (1/4") of mulch.

When the area to be planted exceeds ten thousand square feet (10,000 sq. ft.), a mechanical spreader shall be used. When less than ten thousand square feet (10,000 sq. ft.) and more than two thousand square feet (2,000 sq. ft.), the use of a hand planter or mechanical planter is optional; and when less than 2,000 square feet, hand planting or broadcasting with mulch is optional.

The planted stolons shall not be allowed to dry out. Watering shall begin immediately after planting and the stolons kept moist at all times until the plants are well established.

When overseeding is required, the seed shall be spread in accordance with Section 20-4.081, Method A, immediately after planting stolons.

**20-4.09 Erosion Control Planting** - Erosion control planting shall be for slope protection. Topsoil grading and conditioning shall be in accordance with Section 20-4.03.

**20-4.091 Straw Stabilization** - When straw stabilization is specified, Type 5 mulch shall be incorporated into the slope topsoil either by discing or with a steel plate studded roller. The steel plate studs shall be at least six inches (6") long, not more than six inches (6") wide, and approximately one inch (1") thick with rounded edges. The roller shall be capable of forcing the straw into the soil a sufficient depth to tie down the surface soils.

**20-4.092 Seeding and Mulching** - Seed, fertilizer, mulch, and other specified materials may be applied on slopes by Method A or Method B described in Section 20-4.081.

**20-4.10 Sprigging** - Sprigging shall consist of planting turf grasses, cut stems of plants, and plants with attached root system but without adhering soil.

Sprigs shall normally be harvested and planted within a twenty-four hour (24 hr) period. Ice plant sprigs shall be harvested between forty-eight hour (48 hr) and ninety-six hour (96 hr) before planting so that a thin callus is formed over the cut surface of each sprig. Sprigs shall be shaded during callusing, but shall not be moistened.

Turf grasses shall be planted in accordance with Section 20-4.083.

Ice plant sprigs shall be planted in moist soil in holes or furrows four inches (4") deep and the hole or furrow refilled with soil and made firm around the plant in such a manner that the plant is not damaged.

Sprigs shall be planted individually at specified spacing. When row sprigging is specified, planting shall be in furrows cut along the contour of the slope.

If mulching of sprigged areas is required, it shall immediately follow planting.

**20-4.11 Watering** - All seeded and planted areas shall be kept moist during the establishment period.

Contractor shall pay the water bill during plant establishment period.

Areas containing ice plants shall be maintained in a barely moist condition to a depth of one inch (1") below the planted root depth.

When a permanent irrigation system is not available, the Contractor, at his/her expense, shall provide whatever temporary system is necessary to provide adequate watering during the establishment period without erosion detrimental to the planting.

## **20-5. Irrigation System Installation**

The Contractor shall furnish all necessary materials, labor, and equipment required to complete the work of installing the irrigation system in accordance with the Contract Documents.

Large specimen plants shall be planted before installing the irrigation system, as required by Section 20-4.053.

Unless otherwise provided, irrigation system layout shown on the Plans shall be considered schematic. With the City Engineer's approval, the Contractor may make adjustments where necessary to conform to actual field conditions. The irrigation system shall be operational, with uniform and adequate coverage of the areas to be irrigated, prior to planting.

An accurate pressure test needs to be completed after backflow device is installed. This shall help insure the water pressure matches what is specified in the original irrigation design.

All backflow preventers shall be assembled with pipe and fittings of brass and bronze up to two and one-half inches (2.5"). Over two and one-half inches (2.5") use cast iron pipe, spools, and flanges.

Utility service connections shall be as shown on the Plans and/or designated by the utility company. The Contractor shall include in his/her bid all costs for such utility connections shown on the Plans or designated by the utility company. The Contractor at his/her expense shall be responsible for furnishing the labor and materials to connect to the service connection.

Trenches through paved areas shall be resurfaced in accordance with Section 19-4.

After completing the irrigation system, the Contractor shall submit Record-Drawings showing the location of pipe, valves, tubing, wiring, controllers, and electrical services. Such drawings shall be submitted before relief from maintenance and responsibility is granted.

**20-5.01 Irrigation Pipeline Installation** - Trench excavation and backfill including the depth of cover over the pipeline shall be in accordance with requirements of Section 20-4.02.

Pipefitting shall be installed in accordance with the manufacturer's recommendations and these Specifications. When requested by the City Engineer, the Contractor shall furnish the manufacturer's printed installation instructions before pipe installation.

Pipe shall be bedded in at least two inches (2") of finely divided material to provide a firm, uniform bedding. After laying, the pipe shall be surrounded with additional finely divided material to at least two inches (2") over the top of the pipe. Trench backfill, sufficient to anchor the pipe, may be deposited before the pipeline pressure testing, except that joints shall remain exposed until satisfactory completion of testing.

When two (2) or more pipelines are installed in the same trench, they shall be separated by a minimum horizontal clear distance of four inches (4") and they shall be installed so that each pipeline, valve, or other pipeline component may be serviced or replaced without disturbing the other.

All assemblies shall be assembled as specified and in accordance with manufacturer's directions. During installation of pipe, fittings, valves, and other pipeline components, foreign matter shall be prevented from entering the system. All open ends shall be temporarily capped or plugged during cessation of installation operations.

Changes in pipeline size shall be accomplished with reducer fittings.

**20-5.011 Steel Pipeline** - Ends of pipe shall be cut square and reamed to full size with a long taper reamer.

Threads shall be cut with clean sharp dies and conform to American Standard Association Specification B2.

Joints shall be made with a non-toxic non-hardening joint compound applied to the male threads only.

When wrapped pipe is specified, joints and any remaining unwrapped portion of the pipeline shall be similarly wrapped after pressure testing.

**20-5.012 Plastic Pipeline** - Plastic pipe to be jointed shall be primed and then joined by socket type solvent welded fittings, threaded fittings, rubber ring fittings, or by other means specified. When plastic pipe is jointed to steel pipe, the steel pipe shall be installed first.

Plastic pipe shall be cut square, externally chamfered approximately ten to fifteen degrees ( $10^{\circ}$  to  $15^{\circ}$ ), and all burrs and fins removed.

Primer/solvent welded joints shall be made in accordance with ASTM D-2855. The primer/solvent recommended by the manufacturer shall be used.

Plastic pipe installation shall be in accordance with ASTM D-2774 and the requirements herein.

Care shall be exercised in assembling a pipeline with solvent welded joints so that stress on previously constructed joints is avoided. Handling of the pipe following jointing, such as lowering the assembled pipeline into the trench, shall not occur prior to the set times specified in ASTM D-2855.

Primer/solvent shall be applied to pipe ends in such a manner that no material is deposited on the interior surface of the pipe or extruded into the interior of the pipe during jointing.

Excess primer/cement on the exterior of the joints shall be wiped clean immediately after assembly.

Threads for plastic pipes shall be as specified in Section 20-5.011 above. A plug shall be installed in the bore of the pipe to prevent distortion prior to threading.

Threaded pipe joints shall be made using Teflon tape or other approved jointing material. Solvent shall not be used with threaded joints.

Pipe shall be protected from tool damage during assembly. Vices shall have padded jaws and strap wrenches shall be used for installation of fittings, and nipples.

Plastic pipe that has been nicked, scarred, or otherwise damaged shall be removed and replaced. Plastic pipes shall be sanded from side to side in the trench to allow three and twenty-eight hundredths feet (3.28') of expansion and contraction per one foot (1') per one hundred feet (100') of straight run.

The pipeline shall not be exposed to water for twenty-four hours (24 hrs) after the last solvent welded joint is made.

#### **20-5.013 Copper Pipeline** - Copper pipeline shall be made with sweated solder joints.

Before jointing, the end of the pipe for the depth of the fitting, and the interior of the fitting shall be buffed to a bright finish and coated with solder flux. The assembled joint shall be made with a fifty-fifty (50/50) tin-lead solder. A continuous solder bead shall show around the joint circumference after soldering.

Copper pipe shall be jointed to steel or cast iron pipe with a dielectric union.

**20-5.02 Installation of Valves, Valve Boxes, and Special Equipments** - Valves, backflow preventer, pressure regulators, and related accessories shall be furnished and installed as specified.

All valves and other equipment shall be installed in a normal upright position unless otherwise recommended by the manufacturer, and shall be readily accessible for operation, maintenance and replacement. Sectional control valves shall not be located within range of sprinklers they control.

Valves shall be the same size as the pipeline in which they are installed. Valves two inches (2") or smaller shall be ball valves. Valves larger than two inches (2") shall be gate valves.

Gate valves and sectional control valves shall be installed below ground. Gate valves shall be housed in a covered concrete box that shall permit access for servicing. Sectional control valves shall be equipped with a sleeve and cap centered on the valve stem.

Quick-coupler valves and garden valves projecting above grade shall be installed three feet (3') from the curbs, pavement, and walks. In lawn areas, such equipment shall be installed in a covered concrete box set to finished grade.

In ground cover and shrubbery areas, quick-coupler valves shall be set to finished grade, and garden valves shall be set between twelve inches (12") and fifteen inches (15") above finished



grade. Quick-coupler valves and garden valves shall be installed on a triple-swing-joint riser assembly as described in Section 20-5.032 and secured to a driven No. 4 reinforcing steel rod as described in Section 20-5.032.

All valve boxes, pipe sleeves, and caps shall be set to finished grade, and valves shall be set at sufficient depth to provide clearance between the cover and the cap, valve handle, or key when the valve is in the fully open position.

Valve boxes shall be set to finished grade on a six inch (6") layer of three-quarter inch (3/4") crushed rock. A continuous piece of one-quarter inch (1/4") to one-half inch (1/2") mesh, 19 gauge minimum galvanized woven wire cloth between the box and crushed rock.

Backflow preventers shall be provided with pipe supports and the accessories necessary to properly secure the assembly.

**20-5.03 Sprinkler Head Installation and Adjustment** - In accordance with the requirements of Section 20-5.05, all mains and laterals, including risers, shall be flushed and pressure tested before installing sprinkler heads, after which a water coverage test shall be performed.

**20-5.031 Location, Elevation and Spacing** - Sprinkler head spacing shall not exceed the maximum shown on the plans or recommended by the manufacturer.

In new lawn areas, sprinkler heads shall be installed three inches (3") above grade and then reset flush with the finished surface just prior to the first mowing. Lawn sprinklers shall be installed two inches (2") clear of adjacent walks, curbs, paving, hedges, and similar improvements.

Sprinkler heads shall be installed four inches (4") from adjacent vertical elements projecting above grade such as walls, planter boxes, curbs, and fences.

Shrub heads, bubbler heads, and oscillating sprinklers shall be installed six inches (6") above finished grade.

Nozzle lines shall be installed at least twelve inches (12") above finished grade. Sprinkler heads projecting above finished grade shall be at least twelve inches (12") from adjacent curbs, walks, paving, and similar improvements.

**20-5.032 Riser and Nozzle Line Installation** - To obtain optimum coverage of the area, risers shall be oriented perpendicular to finished grade.

Risers for oscillating sprinklers and nozzle lines shall be galvanized steel pipes. All other risers shall be Schedule 80 PVC. All pipe between the connection and the lateral, or main and the sprinkler head shall be threaded.

Sprinkler head riser assembly shall be top outlet, triple-swing joint as specified herein.

Sprinkler head risers and nozzle risers installed above grade within twenty-four inches (24") of roadway paving, curbs, walks, and similar improvements shall be of the triple swing joint type.

Double-swing joint and triple-swing joint riser assemblies shall utilize a minimum horizontal six inches (6") pipe nipple threaded into a side outlet ell or tee installed in the lateral supply line. For a triple-swing joint, three (3) ells shall be used in the remaining assembly ahead of the vertical riser pipe. For a double-swing joint, two (2) ells shall be used.

Risers for nozzle lines, oscillating sprinklers, and other sprinkler heads installed above grade within twenty-four inches (24") of curbs, walks, roadways, and similar improvements shall be supported by a No. 4 reinforcing steel rod driven into the ground, secured with two (2) stainless steel clamps. The upper end of the rod shall be at finished grade and be of such length that it extends twenty-four inches (24") below the lateral supply line.

Where nozzle lines cannot be supported on adjacent fences, guardrails, and the like, they shall be supported on driven one-half inch (1/2") pipe stakes four feet (4') long at eight foot (8') centers. The nozzle line shall be secured to the top of the stake with three-eighths inch (3/8") anchor rings, and twelve inches (12") long.

**20-5.033 Sprinkler Head Adjustment** - When all sprinkler heads are installed and the irrigation system is operating, each section or unit shall be adjusted and balanced, with all section control valves fully open to obtain uniform and adequate coverage.

Sprinkler heads having adjustable pin nozzles or orifices shall have the pins adjusted to provide a adequate distribution of water over the coverage pattern. The Contractor shall substitute larger or smaller nozzle cores in nonadjustable sprinkler heads as necessary. Relocation of the sprinkler head to a maximum distance of ten feet (10') if necessary shall be required.

If additional work other than the prescribed above is necessary to correct a deficiency in the system installed as specified, such work shall be paid for in accordance with Section 4-1.03 of the Standard Specifications.

**20-5.04 Automatic Control System Installation** - The Contractor shall install a complete automatic irrigation control system including the automatic controller, remote control valves and wiring, and all necessary accessories and utility service connection.

The automatic controller shall be installed outside of the coverage pattern of the irrigation system at the location designated in the Contract Documents. The foundation for the controller shall be concrete of the size shown on the Plan or recommended by the manufacturer. The control components in the controller shall be fused and the chassis shall be grounded.

Remote control valves shall be compatible with the automatic controller. When the valve is to be housed in a valve box, it shall be installed with at least a six inches (6") clearance below the cover. The box shall be set to finished grade on a six inches (6") layer of three-quarter inch (3/4") crushed rock with a continuous piece of one-quarter inch (1/4") to one-half inch (1/2") mesh, nineteen gauge (19 g.a.) minimum galvanized woven wire cloth between the box and crushed rock.

All service wiring shall be installed at the minimum depth specified in Section 20-4.02 in Schedule 40 PVC conduit from the service point to the controller. Above ground conduit shall be Schedule 40 galvanized steel. A separate disconnect switch or combination meter socket, as required, shall be installed between the source of power and the controller. The minimum service wire shall be number twelve (#12) AWG copper (600) volt type TW, THW, or THWN or larger

as required by the Contract Documents or controller manufacturer. Wire splices shall be located only in specified pull boxes and shall be made with a packaged kit approved for underground use or as specified in the Special Provisions. Pull boxes shall be concrete, set to grade on a six inches (6") layer of three-quarter inch (3/4") crushed rock with a continuous piece of one-quarter inch (1/4") to one-half inch (1/2") mesh, nineteen gauge (19 ga.) minimum galvanized woven wire cloth between the box and crushed rock.

Control wiring or hydraulic control tubing shall be housed in conduit between the controller and a concrete pull box installed at least twelve inches (12") outside the limits of the controller foundation, or the structure foundation where the controller is housed.

All other wiring and hydraulic control tubing issuing from the pull boxes shall be direct burial installed in main or lateral waterline trenches wherever practicable.

The wiring or tubing shall be bundled and secured to the lower quadrant of the irrigation pipeline at ten foot (10') intervals with plastic electrical tape. Sufficient slack shall be left in the wiring or tubing to provide for expansion and contraction. When the control wiring or tubing cannot be installed in a pipe trench, it shall be installed a minimum of eighteen inches (18") below finished grade and a bright colored plastic ribbon with suitable markings shall be installed in the trench six inches (6") below grade directly over the wire or tubing.

Control wiring shall be suitably color coded as necessary for identification. All common wire shall be the same color. Unless otherwise required, all control wiring shall be direct burial Type UF, number fourteen (#14) AWG copper. Splices in control wire shall be made in accordance with the requirements for service wire. At least three feet (3') of slack shall be left at each splice and point of connection in pull boxes and valve boxes.

A spare irrigation wire needs to be installed in any trench that runs from the irrigation controller to the last valve of each trench. A one foot (1') loop shall be left in each valve box.

After the final inspection at the end of the ninety (90) calendar day maintenance period, Contractor/Developer shall need to turn over the utility meter numbers and utility account numbers to the City of Salinas upon final acceptance.

All wiring shall be tested for continuity, open circuits, and unintentional grounds prior to connecting to equipment. When tested for a period of four (4) hours, the hydraulic control system shall maintain a constant test pattern of one hundred and twenty-five psi (125 psi).

Upon completion of the work, the control systems shall be in operating condition with an operational chart mounted within the controller cabinet.

**20-5.05 Flushing and Testing** - After completion and prior to the installation of any terminal fittings, the entire pipeline system shall be thoroughly flushed to remove dirt, scale, or other material. After flushing, the following tests shall be conducted in the sequence listed below. The Contractor shall furnish all equipment, materials, and labor necessary to perform the tests and all tests shall be conducted in the presence of the City Engineer.

1. *Pipeline Pressure Test* - A water pressure test shall be performed on all pressure mains before any couplings, fittings, valves and the like are concealed. All open ends shall be capped after the water is turned into the line in such a manner that all air shall be expelled. Pressure mains shall be tested with all control valves to lateral lines closed. The

constant test pressure and the duration of the test shall be six (6) hours at 125 psi.

2. *Sprinkler Coverage Test* - The coverage test shall be performed after sprinkler heads have been installed and shall demonstrate that each section or unit in the irrigation system is balanced to provide uniform and adequate coverage of the areas serviced. The Contractor shall correct any deficiencies in the system in accordance with the requirements of Section 20-5.03.
3. *Operational Test* - The performance of all components of the automatic control system shall be evaluated for manual and automatic operation.

During the maintenance period and at least fifteen (15) calendar days prior to final inspection, the Contractor shall set the controller on automatic operation and the system shall operate satisfactorily during such period. All necessary repairs, replacements, and adjustments shall be made until all equipment; electrical work, controls, and instrumentation are functioning in accordance with the Contract Documents, Plans, and the Special Provisions.

## **20-6. Plant Establishment Work**

Plant establishment work shall consist of caring for the landscape planting as specified in this Section 20-6 and in the Special Provisions.

The City Engineer shall notify the Contractor in writing of the start of the following plant establishment periods and shall furnish statements regarding days credited to the plant establishment work after said notification:

*Type 1* - Plant establishment period shall be the number of working days specified for plant establishment in the Special Provisions and shall begin after all work has been completed, except plant establishment work.

*Type 2* - Plant establishment period shall be the time between completion of all planting work (except plant establishment work) and acceptance of the Contract, provided however, that the Contract shall not be accepted unless the plant establishment work has been satisfactorily performed for at least the number of working days specified for plant establishment in the Special Provisions.

If relief from maintenance and responsibility is granted for a completed portion of the work, as provided in Section 7-1.15, "*Relief from Maintenance and Responsibility*", Type 2 plant establishment period for the completed portion shall be the time between completion of all planting work (except plant establishment work) and the granting of relief from maintenance and responsibility, provided however, that the relief shall not be granted unless the plant establishment work in the completed portion of the work has been satisfactorily performed for at least the number of working days specified for plant establishment in the Special Provisions.

The time required for plant establishment work shall be considered as included in the total time limit specified for the Contract.

The Contractor shall be required to adequately water plants, replace unsuitable plants, do weed, rodent and other pest control, and other work, as determined necessary by the City Engineer, every calendar day during the plant establishment period.

During the plant establishment period, damage caused by erosion shall be repaired as provided in Section 7-1.16, “*Contractor’s Responsibility for the Work and Materials.*”

Working days upon which no work shall be required, as determined by the City Engineer, shall be credited as one of the plant establishment working days, regardless of whether or not the Contractor performs plant establishment work.

Working days when the Contractor fails to adequately perform plant establishment work including but not limited to watering plants replacing unsuitable plants, do weed, rodent, and other pest control, determined to be necessary by the City Engineer, shall not be credited as plant establishment working days.

When ground cover plant growth extends onto sidewalks, curbs or dikes, all ground cover plant growth within six inches (6”) of the sidewalk, curb, or dikes shall be removed. Ground cover plant growth within six inches (6”) of shoulders, walls, or fences shall be removed.

Ground cover shall be kept removed from within planting basins, including the basin walls, and from planting areas within header boards.

Commercial fertilizer shall be applied to trees, shrubs, vines, and ground cover areas as specified in the Special Provisions and shall be watered into the soil after each application. The Contractor shall notify the City Engineer at least two (2) days prior to applying each application of commercial fertilizer.

Plants shall be kept watered as provided in Section 20-4.11, “*Watering*”. Basins and basin walls shall be kept well formed and free from weeds. Weeds shall be kept removed from planting areas within header boards.

Plants that show signs of failure to grow at any time, or which are so injured or damaged as to render them unsuitable for the purpose intended, as determined by the City Engineer, shall be removed and replaced within one (1) week after the City Engineer marks or otherwise indicates that the plants shall be replaced. Replacement plants shall be furnished and planted by the Contractor at his/her expense.

Vines next to fences shall be kept tied to the fences as provided in Section 20-4.07, “*Ground Cover and Vine Planting*”.

Weeds, which appear in, asphalt concrete or rock sealed areas shall be killed before they exceed two inches (2”) in height or width by spraying with a chemical weed killer, which shall not stain the surfacing.

All planted areas shall be kept free of debris and shall be weeded and cultivated at intervals not to exceed seven (7) calendar days or as specified in the Special Provisions. The first mowing of lawn areas shall be performed when the grass is two and one-half inches (2-1/2”) high and shall be repeated as often as is necessary to maintain the lawn at a height of two inches (2”). In no case shall the lawn be cut lower than one and one-half inches (1-1/2”) in height.

The City Engineer shall designate any required pruning of plants at the start of the plant establishment period and the Contractor shall perform the pruning as part of the plant establishment work.

Where the Special Provisions or the City Engineer permits chemical weed control, weeds shall be killed before they exceed two inches (2") in height.

Where weed control is permitted by the Special Provisions, they shall be mowed as close to the ground as possible before they exceed six inches (6") in height.

Where weeds are to be pulled by hand as specified in the Special Provisions, they shall be pulled before they exceed four inches (4") in height or width.

Weed control, as specified in this Section 20 -6, shall be performed as often as required to maintain the project in a neat and uniform condition at all times.

At the time of acceptance of the project all planted areas shall be in a weed free or neatly mowed condition.

Surplus earth, papers, trash, and debris, which accumulate in the planted areas shall be removed and disposed of in accordance with the provisions in Section 7 -1.13, "*Disposal of Material Outside the Highway Right-of-way*", and the planted areas shall be so cared for as to present a neat and clean condition at all times.

During the plant establishment period, trees, shrubs, and ground cover plants shall be pruned or headed back by the Contractor at his/her expense when directed by the City Engineer.

In order to carry out the plant establishment work, the Contractor shall furnish sufficient workers and adequate equipment to perform the work during the plant establishment period.

**20-7. Guarantee** - The entire irrigation control system shall be guaranteed against defects in materials and workmanship for a period of one (1) year from the date of acceptance of the work. Such defects shall include but is not limited to settlement of trenches, re-adjustment of sprinkler heads or valve boxes, and replacement of unhealthy trees and plants. The Contractor shall furnish a faithful performance bond in the amount specified in the Contract documents to cover the guarantee.

**20-8. Measurement and Payment** - The lump sum or unit prices set forth in the Contract documents shall include full compensation for furnishing all labor, materials, tools, equipment, and performing all work necessary to complete and maintain the landscape and irrigation work described or specified in the Contract documents.

When the Contract does not include a separate item(s) for work required under this Section 20, then payment for the required work shall be considered included in the prices paid for the various Contract items of work and no additional compensation shall be allowed therefore.

## **SECTION 21**

**(BLANK)**

## **SECTION 22**

### **FINISHING ROADWAY**

Finishing roadway shall be as specified in Section 22 of the State Standard Specifications.

**SECTION 23**

**(BLANK)**

**SECTION 24**

**LIME TREATMENT**

Lime treatment shall be as specified in Section 24 of the State Standard Specifications.

**SECTION 25**

**AGGREGATE SUBBASES**

Aggregate subbases shall be as specified in Section 25 of the State Standard Specifications except as herein modified.

**25-1.02D Class 6, Class 7, and Class 8 Aggregate Subbases** - Aggregate for Class 6, Class 7, and Class 8 Aggregate Subbases shall be clean and free from vegetable matter and other deleterious substances, and shall be of such nature that it can be compacted readily under watering and rolling to form a firm stable base.

The percentage composition by weight of Class 6, Class 7, and Class 8 aggregate subbases shall conform to the gradings shown in the following table for the class specified when determined by Test Method No. Calif. 202:

<b>PERCENTAGE PASSING</b>			
<b><u>Sieve Sizes</u></b>	<b><u>Class 6</u></b>	<b><u>Class 7</u></b>	<b><u>Class 8</u></b>
4 inches	100	-----	-----
3 inches	90 - 100	-----	-----
2-1/2 inches	-----	100	100
No. 4	35 - 90	35 - 70	35 - 70
No. 200	0 - 20	5 - 20	5 - 20

Class 6, Class 7, and Class 8 aggregate subbases shall also conform to the quality requirements shown in the following table for the class specified.

<b><u>Tests</u></b>	<b><u>Test Method No. Calif.</u></b>	<b><u>Class 6</u></b>	<b><u>REQUIREMENT Class 7</u></b>	<b><u>Class 8</u></b>
Sand Equivalent	217	55	30	25
Resistance (R Value)	301	70	70	30

All values listed are minimum values acceptable.

**25-1.06 Measurement** - Quantities of aggregate subbase are computed from the areas on which subbase material is to be placed as shown on the Contract Drawings. The quantity as set forth in the Proposal shall be considered as final unless the City Engineer modifies the typical sections or limits of work as shown on the Contract Drawings. Excepting that the Contractor may, at his/her own expense, have the material weighed by a Public Weightmaster on scales inspected and sealed by the State of California Bureau of Weights and Measures, in which event

a unit wet density of one hundred and fifty pounds/cubic foot (150 lbs/ft<sup>3</sup>) of compacted material shall be used to convert the tons to cy of material in place as evidence by weight tickets furnished to the City Engineer.

**25-1.07 Payment** - Aggregate subbase shall be paid for as specified in the State Standard Specifications except that the cost of furnishing and applying water shall be considered as included in the prices paid for the various Contract items of work and no additional compensation shall be allowed therefore.

**SECTION 26  
AGGREGATE BASES**

Aggregate bases shall conform to Section 26 of the State Standard Specifications, except as herein modified.

**26-1.01 Description** - Delete the second paragraph and insert the following: Aggregate bases are designated as Class 2, Class 3, and Class 4. The class of aggregate base shall be shown on the Plans or specified in the Special Provisions.

**26-1.02C Class 4 Aggregate Base** - Aggregate furnished for Class 4 aggregate base shall be free from vegetable matter and other deleterious substances and shall be of such nature that it can be compacted readily under watering and rolling to form a firm stable base. The aggregate shall consist of any one or a mixture of the following materials:

1. Broken stone or crushed gravel.
2. Natural material having essentially the same qualities of angularity or surface irregularity and roughness as broken stone.
3. Natural rough surface gravel.

The percentage composition by weight of Class 4 aggregate bases shall conform to the following grading when determined by Test Method No. Calif. 202:

<u>Sieve Sizes</u>	<u>Percentage Passing Sieves</u>
2 inches	100
1-1/2 inches	90 - 100
3/4 inch	50 - 100
No. 4	25 - 90
No. 200	3 - 15



**THE CLASS 4 AGGREGATE BASE SHALL CONFORM TO THE FOLLOWING QUALITY REQUIREMENTS:**

<u>Test</u>	<u>Test Method No. Calif.</u>	<u>Requirements</u>
Loss in Wet Shot Rattler	210	Fifty-five (55%) percent Max.
Loss in Los Angeles Rattler (after 500 revolutions)	211	Fifty (50%) percent Max.
Resistance (R-value)	301	75 Min.
Sand Equivalent	217	26 Min.
Plasticity Index	202	6 Max.

**26-1.04 Spreading** - The provisions of the State Standard Specifications shall be modified as follows:

Water shall be introduced into the aggregate base, except for Class 4, prior to spreading in sufficient quantity to prevent segregation and non-uniform thickness of spread.

The use of bottom dump trucks is not precluded if the desired final results can be satisfactorily obtained. New and approved spreading equipment, which shall produce the desired results, may be used. If methods can be developed whereby material can be successfully spread working from windrows, this is satisfactory.

Class 4 aggregate base shall be spread as specified in the State Standard Specifications, except that it may be spread with the use of a motor grader or other equipment that shall provide the uniform layer conforming to the planned section both transversely and longitudinally within the thickness tolerance specified hereafter, without causing segregation of the material.

**26-1.05 Compacting** - Shall be as specified, except that the surface of the finished grade, shall not vary more than five-sixteenths inch (5/16") above or below the finished grade established by the City Engineer. The Contractor shall furnish to the City Engineer all necessary equipment to check the grade variations. Such equipment shall be returned to the Contractor upon completion of checking the work.

**26-1.07 Payment** - Payment for furnishing and applying water after weighing and furnishing equipment to check the grade shall be considered to be included in the prices paid for the various Contract items of work and no additional compensation shall be allowed therefore.

**SECTION 27**

**CEMENT TREATED BASES**

Cement Treated Bases shall be as specified in Section 12 of the State Standard Specifications.

**SECTION 28**

**LEAN CONCRETE BASE**

Lean Concrete Base shall be as specified in Section 28 of the State Standard Specifications.

**SECTION 29**  
**TREATED PERMEABLE BASES**

Permeable Treated Bases shall be as specified in Section 29 of the State Standard Specifications.

**SECTIONS 30 THROUGH 36**  
**(BLANKS)**

**SECTION 37**  
**BITUMINOUS SEALS**

Bituminous seal shall be as specified in Section 37 of the State Standard Specifications, except as herein modified.

**37-1.04 Preparation for Seal Coat** - Add the following to this subsection:

When seal coats are to be applied to asphalt concrete or cut-back pavements (repairs) that are trench resurfacing of less than five years (5 yrs) old, the patches shall be fog sealed with a slow-setting type asphaltic emulsion conforming to the Provisions in Section 94, “*Asphaltic Emulsions*”, at the rate of one tenth gallon/square yard (0.10 gal/yd<sup>2</sup>) If no pay item is provided in the Contract for this work, full compensation for such work shall be considered as included in the prices paid for the various Contract items of work and no additional compensation shall be allowed therefore.

**37-1.05 Applying Asphaltic Emulsion** - Delete the fourth paragraph of this subsection and insert the following:

Asphaltic emulsion shall not be applied when weather conditions are unsuitable. Seal coats requiring screenings shall not be applied until sufficient screenings are on hand to immediately cover the asphaltic emulsion, or when the atmospheric temperature is below 55°F, or if the atmospheric temperature shall be below 50° F during any time of the twenty-four hour day (24 hr/day), or when the pavement temperature is below 65°F. Fog Seal coat shall not be applied when the atmospheric temperature is below 40°F.

**37-1.07 Finishing** - Finishing shall be as specified in the subsection except that the pneumatic-tired rollers shall have a minimum weight of eleven tons (11 tons).

**37-1.09 Payment** - Add to this section the following paragraph:

The cost of traffic control and flagmen and the cost of salvaging the stockpiling of excess screenings shall be considered as included in the prices paid for the various contract items of work and no additional compensation shall be allowed therefore.

**SECTION 38**  
**(BLANK)**

**SECTION 39**  
**ASPHALT CONCRETE**

Asphalt concrete shall be as specified in Section 39 of the State Standard Specifications, except as herein modified.

**39-4.02 Prime Coat and Paint Binder (Tack Coat)** - Delete the first paragraph and insert the following:

A prime coat of liquid asphalt shall be applied to all areas to be surfaced. The roadway or shoulder to be oiled shall be prepared in accordance with the Specifications following that it shall be uniformly watered sufficiently to eliminate dust, but not to such extent as to form mud or pools of water. The application of oil to the roadway or shoulder shall be scheduled to commence after 7:00 a.m. and shall be completed prior to 1:00 p.m., and it is further specified that no oil shall be applied when the air temperature is less than 40°F.

During all oiling operations, precautions shall be exercised to prevent marring or discoloring adjacent improvements and adequate protection against such possibility shall be provided.

After the applied oil has dried, or penetrated to such extent that no free oil remains on the surface, and the condition of the oiled area shall otherwise permit, the roadway or shoulder shall be opened to traffic.

If no pay item is provided in the Contract for this work, full compensation for such work shall be considered as included in the prices paid for the various items of work and no additional compensation shall be allowed therefore.

**39-6.01 General Requirements** - Delete the first paragraph entirely and insert the following:

Unless otherwise provided in the Special Provisions or approved by the City Engineer, placing material in a windrow and then picking it up and placing it in the asphalt paver with loading equipment shall not be allowed except with a Material Transfer Vehicle (MTV).

The Contractor may use a MTV when placing all asphalt concrete plant mix pavements, including open-graded asphalt concrete course, and when placing all full width travel lanes, including shoulders, collector lanes, ramps, and loops.

The MTV shall receive mixture from the hauling equipment and shall independently deliver the mixture from the hauling equipment to the paving equipment. The MTV shall be capable of transferring the material from the haul vehicle to the paver hopper at a uniform and continuous rate and shall allow continuous movement of the paver. A paver hopper insert with a minimum capacity of fourteen tons (14 tons) in the hopper of conventional paving equipment shall be used when utilizing a MTV. The MTV shall be capable of remixing the material prior to discharge into the paver conveyor system. The MTV remixing system shall contain a minimum 14 tons capacity storage bin or a dual pugmill system with two (2) full-length transversely mounted paddle mixers located in the paver hopper insert.

The MTV shall deliver to the paver a homogeneous, non-segregated mixture that is of uniform temperature that shall be less than a 20°F difference between the highest and lowest

temperatures when measured transversely across the width of the mat in a straight line at a distance of one foot (1') to three foot (3') from the screed while the paver is operating. The temperature measurements shall be taken approximately one foot (1') from each edge and at least once in the middle of the mat.

The MTV shall be empty when crossing a bridge and move across without any other Contractor vehicles or equipment being on the bridge. The MTV shall move across the bridge in a travel lane and not on the shoulder. While crossing the bridge, the speed of the MTV shall be no greater than 5 miles/hr and shall not abruptly accelerate or decelerate. The Contractor at his/her expense shall provide approved signing and flagging during the crossing.

In the event the MTV malfunctions during paving operations, plant operations shall immediately discontinue and shall not resume until the MTV malfunctions have been remedied, unless otherwise directed due to safety concerns. The Contractor may continue placement of the mix until any additional mix in transit has been placed, provided satisfactory results are achieved. This procedure shall not alleviate the Contractor from meeting Contract requirements.

Compensation for providing and using the materials transfer vehicle or any associated equipment, shall be considered as included in the Contract unit bid price per ton for asphalt concrete to be placed. If no pay item is provided in the Contract for asphalt concrete, full compensation for providing and using such equipment shall be considered as included in the prices paid for the various Contract items of work and no additional compensation shall be allowed therefore.

**39-6.03 Compacting** - Add the following paragraphs: The Contractor shall furnish to the City Engineer a straightedge that meets the requirements of this subsection to check the pavement surface. Such straightedges shall be returned to the Contractor upon completion of checking the work.

Should the pavement surface not meet the tolerances required under this subsection and the temperature of the pavement material be below 150°F, the surface of the pavement shall be brought to a true grade cross section by removing the paving material in the area to be repaired, by an approved method, that shall provide a minimum layer depth of one inch (1") of the new pavement at the joint line. Repairs shall not be made to pavement surfaces by feather edging at joints.

Compaction after rolling shall be ninety-five percent (95%) of the density obtained with the California Kneading Compactor per Calif. Test 304. The field density of compacted asphalt concrete shall be determined by:

1. A properly calibrated nuclear asphalt testing device in the field, or
2. ASTM D-1188 when slabs or cores are taken for laboratory testing. Zinc stearate may be substituted for paraffin.

In case of dispute, method 1 shall be used.

**39-8.02 Payment** - Add the following paragraph to this subsection:

The Contractors attention is directed to Section 6-3.02, *Testing by Contractor*. If no pay item is provided in the Contract for furnishing straightedge, repairs, and compaction testing, then payment for furnishing straightedge, repairs, and compaction testing shall be considered as included in the prices paid for in the various Contract items of work and no additional compensation shall be allowed therefore.

**SECTION 40  
PORTLAND CEMENT CONCRETE PAVEMENT**

Portland cement concrete pavements shall be as specified in Section 40 of the State Standard Specifications.

**SECTION 41  
PAVEMENT SUBSEALING**

Pavement subsealing shall be as specified in Section 41 of the State Standard Specifications.

**SECTION 42  
GROOVE AND GRIND PAVEMENT**

Groove and grind pavement shall be as specified in Section 42 of the State Standard Specifications.

***SECTIONS 43 THROUGH 48  
(BLANKS)***

**SECTION 49  
PILING**

Piling shall be as specified in Section 49 of the State Standard Specifications.

**SECTION 50  
PRESTRESSING CONCRETE**

Prestressed concrete members shall be as specified in Section 50 of the State Standard Specifications.

**SECTION 51  
CONCRETE STRUCTURES**

Concrete structures shall be as specified in Section 51 of the State Standard Specifications, except as herein modified:

Minor Structures - In lieu of the Provisions of Section 51-1.02, 51-1.05, 51-1.22, and 51-1.23 of the State Standard Specifications, such pipe headwalls, drop inlets, catch basins, and such other miscellaneous concrete structures that are identified on the Plans and/or in the Special Provisions as minor structures and are listed in the Proposal as separate items shall be paid for at the Contractor price for each structure so listed which price shall include full compensation for all excavation, backfill, reinforcing steel, stops, metal frames, covers, grates, unused pipe stubs, and pipe connections into the structures as provided for in the Special Provisions or as shown on the Plans. Minor structures, at the option of the Contractor, may be furnished and installed as precast units provided the structures in place are equal in all respects to cast in place construction as specified herein.

**51-1.12C Premolded Expansion Joint Fillers** - In lieu of the requirements of the State Standard Specifications, insert the following:

Unless otherwise provided in the Special Provisions, premolded joint fillers shall have a minimum content of thirty-five percent (35%) and a maximum of fifty percent (50%) air-blown asphalt by weight. The thickness shall be three-eighths inch (3/8"). The basic material shall be cane fiber.

## **SECTION 52 REINFORCEMENT**

Reinforcement shall be as specified in Section 52 of the State Standard Specifications.

## **SECTION 53 SHOTCRETE**

Shotcrete shall be as specified in Section 53 of the State Standard Specifications, except as herein modified:

**53-1.01 Description** - Add the following paragraph:

Shotcrete proposed or approved for use, as structural concrete shall be in accordance with American Concrete Institute (ACI) Shotcrete Guide 506R-90. The Contractor's attention is directed to that section of the Guide for placement of steel reinforcing bars to be used in shotcrete.

## **SECTION 54 WATERPROOFING**

Waterproofing shall be as specified in Section 54 of the State Standard Specifications.

## **SECTION 55 STEEL STRUCTURES**

Steel structures shall be as specified in Section 55 of the State Standard Specifications.

## **SECTION 56**

### **SIGNS**

Sign structures and roadside signs shall be as specified in Section 56 of the State Standard Specifications, except as herein modified:

**56-2.01 Description** - Add the following paragraph:

Street name signs and traffic signs shall be as specified in the Special Provisions and per City Standard Plans.

## **SECTION 57**

### **TIMBER STRUCTURES**

Timber structures shall be as specified in Section 57 of the State Standard Specifications.

## **SECTION 58**

### **PRESERVATIVE TREATMENT OF LUMBER, TIMBER AND PILING**

Preservative treatment of lumber, timber, and piling shall be as specified in Section 58 of the State Standard Specifications.

## **SECTION 59**

### **PAINTING**

Painting shall be as specified in Section 59 of the State Standard Specifications.

## **SECTION 60**

**(BLANK)**

## **SECTION 61**

### **CULVERT AND DRAINAGE PIPE JOINTS**

Culvert and drainage pipe joints shall be as specified in Section 61 of State Standard Specifications. Storm Drain line shall be televised per Section 71-3.03.

## **SECTION 62**

### **ALTERNATIVE CULVERTS**

Alternative culverts shall be as specified in Section 62 of the State Standard Specifications.

## **SECTION 63**

### **CAST-IN-PLACE**

Cast-In-Place concrete pipes shall be as specified in Section 63 of the State Standard

Specifications except as herein modified.

**63-1.05 Construction** - Delete this subsection in its entirety and insert the following paragraphs:

An approved method or device shall be used when placing invert concrete to insure that thickness is maintained at not less than minimum wall thickness at any point. Approval of this method or device shall be obtained from the City Engineer prior to commencement of work. Flow line elevations shall not vary more than five-hundredth foot (0.05') from the design grade line.

A starter section shall be used at the beginning of each run of cast-in-place concrete pipe unless indicated otherwise on the Plans or approved by the City Engineer.

A closing section shall be used where indicated on the Plans or as directed by the City Engineer, where it is not possible to complete a run of cast-in-place concrete pipe because of lack of clearance ahead in the trench.

If construction of the pipe stops short of a manhole, or for a period of time exceeding twenty minutes (20 min.), the resulting construction joint shall be reinforced with a concrete collar, which may be either precast or cast-in-place. This collar shall extend one foot either side of the joint, and shall be of a minimum thickness equal to that of the pipe.

When using a total pipe riphery, metal form process, care shall be exercised to keep the machine vertical. A deflection of more than five degrees ( $5^{\circ}$ ) from vertical shall not be allowed.

When metal slip forms are used to form the invert of the pipe, the invert shall be hand troweled to a smooth and even finish immediately after placement.

Variations in the internal diameters shall not exceed one thirty-second inch ( $1/32''$ ) per diameter inch. Offsets at form laps shall not exceed the limits specified in the following:

<u>PIPE DIAMETER</u>	<u>MAXIMUM OFFSET</u>
24 inches	3/8 inch
30 inches	3/8 inch
36 inches	1/2 inch
42 inches	1/2 inch
48 inches	5/8 inch
54 inches	5/8 inch
60 inches	5/8 inch
72 inches	7/8 inch

Forms shall be strong enough to withstand the vibrating of the concrete and to permit workmen to place the concrete without causing distortion at any point, and form support system shall be constructed so that previously placed concrete shall not be damaged.

Form structure bearing plate indentations shall not exceed one eighth inch ( $1/8''$ ) inch and the remaining interior surface of the pipe shall be equivalent to a steel screened finish. All extraneous concrete shall be removed from the interior surfaces as soon as possible after placing.



Care shall be taken when removing the forms to prevent damage to the pipe. After removal of the forms, the inside of the pipe shall be inspected and any repairs made promptly. If obvious segregation, rock pockets, honeycombing, or inadequate wall thickness is encountered during inspection the pipe may be rejected by the City Engineer.

**63-1.06 Curing** - Delete this subsection in its entirety and insert the following paragraphs:

Immediately after the exposed exterior surfaces are finished, the exposed surfaces shall be covered with a polyethylene film, at least two-thousandth inch (0.002") in thickness, or other approved waterproof material for curing purposes. The sole use of a liquid sealing or curing compounds shall not be allowed. As soon as it is possible, without causing damage to the fresh concrete pipe, a loose, moist layer of initial backfill material, six inches (6") in thickness, may be hand placed on the concrete in accordance with Section 19-4 of these Specifications.

Unrestricted traffic may be permitted over the pipe when concrete strength reaches 1500 psi and pipe has been in place seventy-two hours (72 hrs). In all cases, the Contractor shall be responsible for correcting any damage to cast-in-place concrete pipe caused by premature or excessive loading prior to the end of a seven (7) calendar day curing period.

All openings into the pipe shall be kept tightly closed at all times during construction, except where work is in progress and for a minimum time of seven (7) days after placement.

**63-1.07 Reinforced Cast-In-Place Pipe** - In lieu of the "Blank" section of the State Standard Specifications insert the following paragraphs:

The specification for cast-in-place concrete pipe shall apply in full force for the construction of reinforced cast-in-place concrete pipe except that the minimum thickness of walls shall not be less than four inches (4"). Reinforcement shall equal or exceed ASTM Designation: C-76 and shall be lapped ten inches (10") where spliced.

Any obvious segregation, rock pockets, honeycombing, cracks, inadequate wall thickness or any other indications of failure or inadequacy that are observed may be considered as cause for rejection of any portion or all of the pipe.

Prior to final acceptance, small diameter pipe shall be checked by viewing with television equipment in accordance with Section 71-3.03 of these Standard Specifications.

Pressure tests shall be required on any section of cast-in-place concrete pipe designed to operate under head.

**63-1.08 Measurement** - Delete this subsection in its entirety and insert the following paragraphs:

The length of pipe to be paid for shall be the slope length measured between centers of manholes or other end of the pipe in other structures. Pipe placed in excess of the length designated shall not be paid for.

Structure excavation and backfill, trench excavation and backfill, all material, including concrete and reinforcing steel, pavement cutting and replacement, and all other items of work required to install the pipe complete-in-place shall be considered as part of the item for cast-

in-place pipe and no additional payment shall be made therefore.

**63-1.09 Payment** - Delete this subsection in its entirety and insert the following paragraphs:

Items of work measured as specified above shall be paid for at the Contract price per linear foot for the various sizes of cast-in-place pipe as described in these Specifications.

The Contract price paid per linear foot for cast-in-place pipes shall include full compensation for all labor, materials, tools, equipment, and incidentals and for doing all the work involved in installing the pipe, complete-in-place as shown on the Plans, as specified in these Specifications, and the Special Provisions.

## **SECTION 64 PLASTIC PIPE**

Plastic pipe shall be as specified in Section 64 of the State Standard Specifications; except as herein modified.

**64-1.01 Description** - Add the following paragraph:

Plastic Pipe specified for use as sanitary sewer or storm sewer and sewer structures shall be constructed in accordance with Section 71, "*Sewers*," of these Standard Specifications.

## **SECTION 65 REINFORCED CONCRETE PIPE**

Reinforced concrete pipe shall be as specified in Section 65 of the State Standard Specifications, except as herein modified.

**65-1.10 Payment** - In lieu of the portions of this section pertaining to structure excavation and structure backfill, those items shall be considered as included in the price paid for other items, as well as pavement cutting and replacement, and no additional compensation shall be allowed therefore.

## **SECTION 66 CORRUGATED METAL PIPE**

Corrugated metal pipe shall be as specified in Section 66 of the State Standard Specifications.

## **SECTION 67 STRUCTURAL STEEL PLATE PIPE**

Structural metal plate pipes shall be as specified in Section 67 of the State Standard Specifications.

**SECTION 68**  
**SUBSURFACE DRAINS**

Subsurface drains shall be as specified in Section 68 of the State Standard Specifications.

**SECTION 69**  
**OVERSIDE DRAINS**

Overside drains shall be as specified in Section 69 of the State Standard Specifications.

**SECTION 70**  
**MISCELLANEOUS FACILITIES**

Miscellaneous facilities shall be as specified in Section 70 of the State Standard Specifications.

**SECTION 71**  
**SEWERS**

Sewers shall be as specified in this Section 71 in lieu of the (Blank) Section of the State Standard Specifications.

**71-1 Description**

This work shall consist of constructing sanitary sewers, storm sewers, sewer structures, and appurtenances as shown on the Plans, in accordance with these Specifications, the Special Provisions, and as directed by the City Engineer. The work shall include all necessary street cutting, excavation, laying of pipe, backfilling, and repaving to provide a complete sewer of the size and type and to the line and grade as shown on the Plans.

The type of sewer pipe and sewer structure shall be designated on the Plans or in the Specifications.

**71-2 Materials**

Pipe, fittings, miscellaneous materials, and the most common joint materials are described in this Section 71-2. All pipe materials installed in the field shall be tested in accordance with Section 71-3, measured in accordance with Section 71-4 and payments shall be in accordance with Section 71-5.

**71-2.01 Vitrified Clay Sewer Pipe** - Vitrified clay sewer pipe and fittings including perforated pipe shall conform to the specification for extra-strength or high strength manufactured in accordance with ASTM C-700, except that plain end pipe otherwise complying in all respects with said Specifications may be used.

All pipe and fittings shall be clearly marked with the name or trademark of the manufacturer, the location of the plant, and the strength designation. All standard length straight pipe as defined below shall, in addition to the above, be marked with a manufacturer's date code. All fabricated

bends and/or bevels shall be manufactured from pipe meeting all requirements of the pipe Specifications for the project.

The pipe diameter shall not vary from a true circle by more than three percent (3%) of nominal diameter. Except for special purposes, the minimum standard length of straight pipe, exclusive of socket depth, shall be forty inches (40"). Pipe shall not deviate from straight by more than one sixteenth inch (1/16") per foot.

Imperfections in pipe and fittings containing blisters, cracks, and chips in excess of the limits herein shall be rejected; however, certain cracks and chips meeting the following requirements may be repaired in accordance with Section 71-2.014:

**71-2.011 Blisters** - For pipe of nominal sizes three inches (3") to eighteen inches (18"), blisters shall not exceed three inches (3") in any direction, and no blister or pimple shall project more than one eighth inch (1/8") above the surface of the pipe.

For pipe of nominal sizes over eighteen inches (18"), no blister shall exceed in any direction, two inches (2") per foot of internal diameter, and no blister or pimple shall project above the surface of the pipe more than one eighth inch (1/8") per foot of internal diameter.

Pipe shall have no broken blisters.

**71-2.012 Cracks** - There shall be no cracks passing through the barrel or socket except that a single crack at the spigot end of the pipe not exceeding seventy-five percent (75%) of the depth of the socket, or a single circumferential crack in the socket not exceeding three inches (3") in length or a single crack not exceeding two inches (2") in the axial direction is permitted.

**71-2.013 Chips** - Chips on the interior surface shall not exceed two inches (2") in length, one inch (1") in width, and a depth of one-quarter (1/4) of the barrel thickness, but not to exceed one-quarter inch (1/4"). A single pipe shall contain no more than two (2) such defects.

**71-2.014 Repairable Imperfections** - Structurally sound clay pipe equal to or smaller than fifteen inches (15") size, shall be repaired as follows:

Repairs of any type at the spigot or socket, shall be limited to one (1) for each sixty degrees (60°) of circumference, and a maximum of four (4) at either end. Repaired pipe shall not be used for fabricated fittings unless the repaired pipe is tested. Molded fittings may be repaired within the scope of the Specifications.

1. *Cracks* - The following longitudinal cracks parallel to the axis caused by shrinkage or drying and not more than one thirty-second inch (1/32") wide may be repaired:
  - b. A crack on the exterior of the spigot that does not penetrate the entire barrel thickness and does not exceed fifty percent (50%) of the depth of the socket in length.

- c. A crack in the socket of the pipe that does not penetrate the entire thickness and does not exceed seventy-five percent (75%) of the depth of the socket in length.
  - d. A crack that penetrates the entire thickness of the socket and does not exceed fifty percent (50%) of the depth of the socket in length.
  - e. A crack on the interior of the socket and in the shoulder on the exterior of the socket which does not exceed three inches (3") in length and does not penetrate more than twenty percent (20%) of the wall thickness.
2. *Surface Chips* - Surface chips located on the exterior of the spigot, the interior or exterior of the socket, or on the shoulder of the socket may be repaired, provided:
- a. The length of the circumference of the chip does not exceed twice the barrel thickness.
  - b. The width is not greater than fifty percent (50%) of the socket depth measured parallel to the axis.
  - c. The depth is not greater than twenty-five percent (25%) of the wall thickness measured perpendicularly to the axis.
3. *Full Depth Chips* - Full depth chips located on the socket may be repaired provided the length of the chip does not exceed twice the barrel thickness or the width does not exceed twenty-five percent (25%) of the socket depth.

**71-2.015 Fittings and Stoppers** - Fittings shall be made to such dimensions as shall accommodate the joint system specified. Y-branch and T-branch fittings shall be furnished with spurs securely fastened by the manufacturer to the barrel of the pipe. There shall be no projection on the inner surface of the barrel.

T-branch fittings shall have their axis perpendicular to the longitudinal axis of the pipe. The axis of the spur on Y-branch fittings shall be forty-five degrees (45°) from the longitudinal axis of the pipe. The barrel of each spur shall be of sufficient length to permit the proper jointing of the connecting pipe.

Stoppers furnished for installation in branch fittings and ends of pipe left unconnected shall be strong enough to sustain all applied construction and in-place loads, including field pressure test. Stoppers for pipe shall be one (1) of the following: polyethylene (PE), polyurethane, polypropylene, acrylonitrile-butadiene-styrene (ABS), polyvinyl chloride (PVC), ozone-resistant synthetic rubber, clay discs, or other material approved by the City Engineer. The Contractor shall retest within sixty (60) calendar days prior to installation any stopper that is more than one hundred eighty (180) calendar days old from the date of manufacture to ensure compliance with the requirements of the Specification. The Contractor shall not install any stopper that is more than two (2) years old from the date of manufacture.

**71-2.016 Joints** - Joints for vitrified clay pipe shall be synthetic rubber coupling with corrosion-resistant shear ring for plain-end clay pipe, twelve inches (12") maximum or shall consist of polyurethane elastomer sealing components, one (1) bonded to the outside of the

spigot and the other bonded to the inside of the socket. The maximum bevel of the ends of pipe to be laid on a curve is four degrees (4°). Plain-end pipe shall not be beveled.

Each joint within vertical and horizontal curves shall be constructed using factory fabricated mitered or beveled pipe or by deflecting joints. In no case shall joints be deflected more than allowed under ASTM C-425. Shop and layout drawings for mitered or beveled pipe shall be submitted to the City Engineer for review and approval.

**71-2.017 Clay Pipe Repair** - All surfaces to be repaired shall be clean and dry. All unsound material at lumps or blisters shall be ground smooth and flush with adjacent surfaces. Cracks shall be grooved one-eighth inch (1/8") to one-quarter inch (1/4") wide and one-eighth inch (1/8") to one-quarter inch (1/4") deep for the full length of the crack. All unsound material at chips, flakes, pits, and spalls shall be removed and edges shall be one-sixteenth inch (1/16") minimum below adjacent surfaces. There shall be no feathered edges. Prepared areas shall be cleaned of dust and other loose particles and then filled with repair material compounded to provide properties most desirable for sewerage service. Repair material shall resist bacterial attack and attack by chemicals or combinations of chemicals normally present in domestic and industrial sewage.

Repair material shall be mixed, applied, and cured as recommended by the manufacturer and approved by the City Engineer, and shall have a color contrasting with the color of pipe to be repaired. If necessary to produce a contrast in color, carbon black in a small quantity may be added to the repair material. The repair material shall be subject to adhesion and chemical testing as required by the City Engineer to determine its suitability for use.

1. *Adhesion Test* - Vitrified clay bars one inch (1") square in cross section and approximately eight inches (8") in length, compounded of the same materials as the vitrified clay pipe and fired to clay pipe manufacturing temperatures shall be used in preparing test specimens. The bars shall have a modulus of rupture of not less than sixteen hundred psi (1,600 psi) when tested in flexure with third-point loading.

The bars shall be cut through at the midpoint and then bonded with the repair material. Following a seven (7) calendar day maximum cure period at ambient room temperature, the bonded bars shall be tested in flexure with third-point loading.

The average modulus of rupture of five (5) test bars bonded with the repair material shall not be less than sixteen hundred psi (1,600 psi).

Five (5) additional test bars bonded with the repair material and immersed for sixty (60) calendar days in water at ambient room temperature shall have an average modulus of rupture not less than fifteen hundred psi (1,500 psi).

2. *Chemical Test* - Each specimen of repair material shall lose not more than two percent (2%) of its weight after being immersed in a concentration solution of twenty percent (20%) Sulfuric acid, five percent (5%) Ammonium hydroxide, one percent (1%) Sodium hydroxide, one percent (1%) Ferric chloride and one percent (1%) Nitric acid for a period of thirty (30) calendar days.

3. *Inspection of Repairs* - All pipes to be repaired shall be inspected by the City Engineer after preparation for repair, and again after repair has been made. Repairs made without prior inspection shall be rejected. The City Engineer may require re-testing of any

repaired pipe to demonstrate its soundness. The City shall be reimbursed for all costs incurred for inspection and testing of repaired pipe.

Compression couplings for plain end clay pipe shall conform to ASTM C-594-73 and ASTM A-167-70. Shear rings shall be required on all sewer mains.

The ends of the pipe shall be so formed that, when the pipes are laid together and jointed, the pipe shall form a continuous line with a smooth interior surface.

Caps shall be furnished with branch pipes or at the ends of pipes that are to be left unconnected. Caps shall consist of disks of the same material as the pipe, or approved plastic six-hundredth foot (0.06') thick, and shall snugly fit the bell or coupling of the branch pipe and shall be secured in place with pipe joint material.

Vitrified Clay Pipes shall be shipped and handled in such a manner as to prevent impact, shocks and free fall, and shall be kept clean at all times. Cracked or broken pipes shall be permanently removed from the work site by the end of the workday.

Vitrified Clay Pipe shall be of first quality, durable, sound, well burned throughout its entire thickness, and shall give a clear metallic ring when struck with a hammer. It shall be unglazed.

Vitrified Clay Pipe shall have factory fabricated compression joints, or approved equal by the City Engineer. Joints shall meet the minimum requirements of the Specifications for Vitrified Clay Pipe Joints, using materials having resilient properties in accordance with the current revision of ASTM Serial Designation C-425.

When installing clay pipe with compression joints, the mating surfacing shall be wiped clean of dirt, foreign matter, and an approved lubricant shall be applied to the joint surfaces.

Plain End Vitrified Clay Pipe and Fittings shall conform to the requirements specified above for bell and spigot type of clay pipe.

The ends of the pipe shall not be scored, but each end of every length of pipe shall be marked to indicate the depth of insertion into the coupling.

The joints of pipe shall be coupled with preformed rubber gaskets, which shall cushion the abutting ends of pipe or fittings, clamped with corrosion resisting metal compression bands.

**71-2.018 Installation and Field Inspection** - Pipes shall be bedded and backfilled in conformance with Section 19-4, "*Open Trench Operations*" of these Standard Specifications.

**71-2.02 Acrylonitrile-Butadiene-Styrene (ABS) Solid Wall Pipe** - This subsection applies to ABS plastic solid wall pipe for use as sanitary sewers, storm drains, and house connection sewers. Pipe, fittings, and joints shall comply with ASTM D-2751 except house connection sewers shall be gasket joints. Minimum wall thickness shall correspond with SDR 26.

Joint solvent cement shall be an ABS cement conforming to ASTM D-2235. Gaskets shall be manufactured from a synthetic elastomer. The compound shall contain not less than fifty percent (50%) by volume of first-grade synthetic rubber. The remainder of the compound shall consist of pulverized fillers free of rubber substitutes, reclaimed rubber, and deleterious substances.

Gaskets shall be extruded or molded and cured in such a manner as to be dense, homogeneous, and of smooth surface, free of pitting, blisters, porosity and other imperfections. The tolerance for any diameter or profile dimension measured at any cross section shall be  $\pm$  one-thirty-second inch ( $\pm 1/32''$ ).

The pipe and fittings shall be made of ABS plastic which shall meet the minimum cell classification of 1-3-3, or 2-2-3 as defined in ASTM Specification D-1788 and having the chemical composition as follows:

Acrylonitrile-Butadiene-Styrene (ABS) pipe - plastics containing polymers or blends of polymers, or both, in which the minimum butadiene content is six percent (6%), the minimum acrylonitrile content is fifteen percent (15%), the minimum styrene or substituted styrene content or both, is fifteen percent (15%) and the maximum content of all other monomers is not more than five (5) parts by weight per one hundred (100) parts of ABS resin. Additives and fibers, including but not limited to stabilizers, antioxidants, colorants, etc., shall not exceed ten (10) parts by weight per one hundred (100) parts of ABS resin.

Material shall meet or exceed the following values and properties:

<u>PROPERTY</u>	<u>ASTM METHOD</u>	<u>MIN. VALUE BASED ON CELL CLASSIFICATION</u>		
		<u>1-3-3</u>	<u>3-3-2</u>	<u>2-2-3</u>
Izod impact @ $23 \pm 2^{\circ}C$ <i>J/m</i> [ft. lb./in.] of notch	D-256	53 [1]	160 [3]	107 [2]
Deflection Temperature Under load $1820kPa$ [264 psi] $^{\circ}C$ [ $^{\circ}F$ ]	D-648	87 [190]	82 [180]	$43^{\circ} \pm 2^{\circ}C$ [ $110^{\circ} \pm 4^{\circ}F$ ] 87 [190]
Tensile stress at yield point: <i>MPa</i> [psi]	D-638	34.5 [5000]	27.6 [4000]	34.5 [5000]
Specific Gravity: min. max.	D-792		1.0 1.2	1.0 1.2

**71-2.021 Chemical Resistance (Pickle Jar Test)** - The City Engineer may at any time direct the manufacturer to obtain compound samples and to prepare test specimens in accordance with ASTM D-1987. These specimens shall comply with the minimum property values shown below and also with the applicable ASTM requirements.

Tensile and impact exposure specimens shall be immersed in the following solutions for a period of one hundred twelve (112) calendar days. At twenty-eight (28) day intervals, selected specimens shall be removed, washed surface dried, and tested.



**TABLE 71-2.021 (A)**

<u>PROPERTY</u>	<u>ASTM TEST METHOD</u>	<u>INITIAL VALUES</u>	<u>VALUES AFTER 112 DAYS EXPOSURE</u>
Tensile Strength psi	D-638	5,000 min.	5,000 min.
Impact Strength Ft-lbs./in. Size	D-256 Method A of notch, min. 1/2"x1/8"x21/2"	2 of notch, min.	2
Weight Change (%) Unconditioned Conditioned	D-543		± 1.5% max. ± 1.0% max.

**TABLE (B)**

<u>CHEMICAL SOLUTION</u>	<u>CONCENTRATION</u>
Sulphuric Acid (H <sub>2</sub> SO <sub>4</sub> )	20% <sup>1</sup>
Sodium Hydroxide (NaOH)	5%
Ammonium Hydroxide (NH <sub>4</sub> OH)	5% <sup>1</sup>
Nitric Acid (HNO <sub>3</sub> )	1% <sup>1</sup>
Ferric Chloride (FeCl <sub>3</sub> )	1%
Sodium Hypochlorite	1%
Soap	0.1%
Detergent (Linear alkyl benzyl Sulfonate or LAS)	0.1%
Bacteriological	BOD not less than 700 ppm

Volumetric percentages of concentrated reagents of C.P. grade. Weight change specimens shall be 2 inches in diameter and may be molded discs or discs cut from the pipe wall. They shall be conditioned in a mechanical convection oven for seven (7) calendar days at 110°±4°F, then cooled in a desiccator for three (3) hours at 73°±4°F, weighed, and then immersed in the above solutions. At twenty-eight (28) calendar day intervals, selected specimens shall be removed, washed, surface dried, and weighed. These same specimens shall be reconditioned in a mechanical convection oven for seven (7) calendar days at 110°±4°F, then cooled in a desiccator for three (3) hours at 73°±4°F and weighed again. If any specimen fails to meet these requirements at any time, the material shall be rejected.

**71-2.022 Pipe Acceptance** - At the time of manufacture each lot of pipe and fittings shall be inspected for defects, and tested for impact, stiffness, and flattening in accordance with ASTM D-2751.

When testing subsequent to manufacture, the impact requirement shall be excluded. For the flattening requirement, the percentage reduction in pipe diameter shall be not less than fifteen percent (15%) for pipe marked SDR 23.5 or lower and not less than twenty-five percent (25%) for pipe marked with higher SDR numbers. The stiffness requirement is unchanged.

A pipe lot shall consist of all pipes having the same marking number. The lot test specimen shall have a minimum length of four feet (4').

**71-2.023 Marking** - Pipes shall have a home mark to indicate full penetration of the spigot when the joint is made. Pipe shall be marked at five foot (5') intervals or less with a marking number, which identifies the manufacturer, SDR, size, machine, date, and shift on which the pipe was produced.

**71-2.024 Installation and Field Inspection** - Pipes shall be bedded and backfilled in conformance with Section 19-4, "Open Trench Operations" of these Standard Specifications.

**71-2.025 Installation Time Limit** - The Contractor shall erect within sixty (60) calendar days prior to the installation of all pipe and fittings that are more than one hundred eighty (180) calendar days old from the date of manufacture to ensure compliance with the requirements of the Specifications. The Contractor shall not install any pipe that is more than two (2) years old from the date of manufacture.

**71-2.03 ABS or PVC Composite Pipe** - This subsection applies to ABS or PVC composite pipe for use as sanitary sewers, storm sewers, and house connection sewers. Pipe, fittings, and joints shall comply with ASTM D-2680, except as modified herein.

The pipe shall consist of two (2) concentric extruded thermoplastic tubes integrally connected by webs to form a circular truss. The longitudinal void spaces shall be filled with inert material. The maximum average ID of the pipe, as determined by ASTM D-2122, shall be:

<u>NOMINAL SIZE</u>	<u>MAX. AVERAGE ID</u>
Inches	Inches
6	5.81
8	7.90
10	9.88
12	11.83
15	14.80

Joint solvent cement shall conform to Section 71-2.02, paragraph 2 for ABS and to Section 71-2.044 for PVC.

**71-2.031 Material Composition and Testing** - The ABS resin compound used in the manufacture of ABS composite pipe shall conform to the requirements of Section 71-2.02.

**71-2.032 Chemical and Physical Testing** - ABS resins furnished under this subsection shall conform to ASTM D-1987. PVC resins shall conform to ASTM D-638 for tensile strength and ASTM D-256 Method A for impact strength.

**71-2.033 Pipe Acceptance** - Each lot of pipe and fittings shall be inspected for defects and tested for stiffness and deflection in accordance with ASTM D-2680. Installation time shall conform to Section 71-2.025.

A pipe lot shall consist of all pipes having the same marking number. The lot test specimen shall be a minimum length of four feet (4').

**71-2.034 Marking** - Pipes shall have a home mark to indicate full penetration of the spigot when a joint is made. Pipe shall be marked at five foot (5') intervals or less with a marking number, which identifies the manufacturer, size and machine, date, and shift on which the pipe was made.

**71-2.035 Repair** - There shall be no discontinuity of the pipe inner wall. Ruptures in the pipe outer wall may be repaired if the damage is limited to an area that can be encompassed

by a three inch (3") diameter circle superimposed over the damage. Cell filler repair is unnecessary. A solvent welded repair patch of the same material as the pipe, at least equal to the thickness of the pipe outer wall, shall extend at least one inch (1") beyond the damage. When damage exceeds these limits, the damaged section shall be cleanly removed.

**71-2.036 Installation and Field Inspection** - Pipes shall be bedded and backfilled in conformance with Section 19-4, "Open Trench Operations" of these Standard Specifications.

**71-2.04 PVC Plastic Pipe** - This subsection applies to the requirements for unplasticized PVC plastic pipe for sanitary sewers, storm sewers, and house connection sewers. Pipe, fittings, couplings, and joints shall conform to the requirements listed in Table 71-2.04 (A), except as otherwise modified by the Plans or the Specifications.

**TABLE 71-2.04 (A)**

<u>NOMINAL PIPE SIZE</u>	<u>ASTM</u>	<u>WALL THICKNESS MIN.</u>
Inches		
4-15	D-3034	SDR 26
18-30	F-679	"T-1" only

Joints for sanitary sewers, except house connection sewers, shall be gasket joints.

**71-2.041 Manufacturer Identification Marks** - All pipe, fittings, and couplings shall be clearly marked at intervals not to exceed five feet (5') as follows:

1. Nominal pipe diameter.
2. PVC cell classification.
3. Company, plant, shift, ASTM, SDR, and date designation.
4. Service designation or legend.
5. For fittings and couplings, the SDR designation is not required.

**71-2.042 Cell Classification** - Pipes shall be made of PVC plastic having a cell classification of 12454-B, 13364-A, or 13364-B as defined in ASTM D-1784. The fittings shall be made of PVC plastic having a cell classification of 12454-B, 12454-C, or 13343-C. PVC compounds of other cell classifications shall be prequalified as specified in 71-2.041. Additives and fillers, including but not limited to stabilizers, antioxidants, lubricants, colorants, etc., shall not exceed ten (10) parts by weight per one hundred (100) of PVC resin in the compound.

**71-2.043 Joining Systems** - All pipes shall have a home mark on the spigot end to indicate proper penetration when the joint is made. The socket and spigot configurations for the fittings and couplings shall be compatible to those used for the pipe.

1. *Elastomeric Gasket Joints* - Pipe with gasket joints shall be manufactured with a socket configuration, which shall prevent improper installation of the gasket and shall ensure that the gasket remains in place during the joint operation. The gasket shall be manufactured from a synthetic elastomer and shall not be more than two (2) years old from the date of manufacture.

2. *Solvent Cement Joints* - Pipe with solvent cement joints shall be joined with PVC cement conforming to ASTM D-2564.
3. *Injection Sealed Joints* - Pipe with injection sealed joints shall be sealed with a PVC adhesive compound. The compound shall conform to the requirements of ASTM D-2564 and shall have a minimum viscosity of fifty thousand centipoise (50,000 cP). The internal diameter of the socket shall be uniform with a locking taper at the base and an outer seal ring attached to the end. The socket shall have an injection port to inject the adhesive and an exhaust port on the opposite side to allow air to escape from the annular space.

**71-2.044 Test Requirements** - Pipe, fittings, and couplings shall meet the requirements of the Section titled “Requirements” of ASTM D-3033, D-3034, or F-679 (“T-1” wall only). During production of the pipe, the manufacturer shall perform the specified tests for each pipe marking. A certification by the manufacturer indicating compliance with Specification requirements shall be delivered with the pipe. The certification shall include the test result data. The PVC compound shall also meet the chemical resistance requirements of Section 71-2.021.

1. *Acceptance* - The basis for acceptance shall be the inspection of pipe, fittings, and couplings; the tests specified in Section 71-2.044; and compliance with the Specifications. When the pipe is delivered to the work site, the City Engineer may require additional testing to determine conformance with the requirements of pipe flattening, impact resistance, pipe stiffness, and extrusion quality. Installation time shall conform to Section 71-2.025.
2. *Selection of Test Pipe* - When the City Engineer requires testing, one (1) test pipe shall be selected at random by the City Engineer from each twelve-hundred feet (1,200’) or fraction thereof of one test pipe per lot. A lot shall be defined as pipe having the same identification marking. The length of specimen for each selected pipe shall be a minimum of eight feet (8’).
3. *Chemical Resistance and Physical Testing* - All resins furnished under this subsection shall conform to Section 71-2.021 except as modified herein.

**TABLE 71-2.044C (A)**

<u>PROPERTY</u>	<u>ASTM TEST METHOD</u>	<u>VALUE (INITIAL AND AFTER 112-DAY EXPOSURE)</u>		
		<u>CELL CLASSIFICATION</u>		
		<b>12454</b>	<b>13343</b>	<b>13364</b>
Tensile Strength psi, min.	D-638	7000	6000	6000
Impact Strength	D-256 Method A			
Ft.-lbs./in. notch min. weight Change %	Size 1/2"x1/8"x2 1/2"	0.65	1.5	1.5
Unconditioned	D-543	± 1.5 max.	± 1.5 max.	± 1.5 max.
Conditioned		± 1.0 max.	± 1.0 max.	± 1.0 max.

4. *Installation and Field Inspection* - Pipe shall be bedded and backfilled in conformance with Section 19-4, “*Open Trench Operations*” of these Standard Specifications.

**71-2.05 Annular High Density Polyethylene Pipe with Smooth Interior, Corrugated Exterior, with Bell-and-Spigot Joints** - These Specifications are intended to be used for the construction of gravity flow storm drains, culverts, and subsurface drains. The size, type, and cell classification of the pipe to be furnished shall be as shown on the Plans or in the Specifications. If the cell classification is not shown on the Plans or in the Specifications, High Density Polyethylene (HDPE) plastic pipe and fittings with smooth interior liner, annular corrugations, and bell-and-spigot joints shall conform to cell classification 324420C or higher and Section 64 “*Plastic Pipe*” of these Standard Specifications.

**71-2.051 Specification for HDPE Profile Wall Pipe:**

1. **Material** - High Density Polyethylene (HDPE) profile wall pipe shall be manufactured in accordance with ASTM F-894. The pipe resin shall be made of HDPE plastic compound having a cell classification of 335444C or higher in accordance with ASTM D-3350. Clean rework material generated by the manufacturers own production may be used so long as the pipe produced meets all the requirements of this Section.
2. **Pipe and Fittings** - The Ring Stiffness Class (RSC) per ASTM F-894 for the pipe and fittings shall be shown on the Contract drawings. Pipe and fittings shall be manufactured by the continuous winding of an extruded profile onto suitably sized mandrels with no external welding between the individual profiles. Profile shapes shall be (1) open profile with circular-core external ribs or (2) solid wall.
3. **Joining** - Pipe joining shall be effected by compressing a gasket between a bell and a spigot, which are integrally wound onto the pipe wall with no external weld or fusion. The gasket shall be contained in a machine groove on the pipe spigot except for pipe used to connect to HDPE manholes, fittings, and structures. Pipe connecting to HDPE manholes, fittings, and structures shall have a smooth surface suitable for gasket sealing. Field fusion for the purpose of joining pipe is not permitted.
4. **Joint Performance** - The joint shall show no signs of leakage when tested in accordance with ASTM D-3212 per Section 8.7 of ASTM F-894 at ten and eight-tenths psi (10.8 psi). Gaskets shall be elastomeric, comply with ASTM F-477, and have an extruded shape with fins or chevrons oriented to promote sealing against external groundwater. The lubricant used for assembly shall have no detrimental affect on the gasket or pipe. The manufacturer shall certify that the joints meet ASTM D-3212.
5. **Pipe Inside Diameter** - The average inside diameter shall be true to the specified pipe diameter and within the tolerances given in Table 1 or 2 of ASTM F-894. Except for mandrel breakout lines running in the direction of flow and mold marks, the inner wall of the pipe shall be smooth and have no visible, circumferential weld seams so as to provide a typical Manning N factor of ten-thousandths 0.010 for clean water. Per ASTM F-894, slight lines and mold marks are permissible provided that they do not result in variation of the inside diameter of more than one-eighth inch (1/8”) from that obtained on adjacent unaffected portions of the surface.
6. **Minimum Wall Thickness** - The minimum wall thickness shall be equal to the minimum waterway wall thickness specified in Table 1 of ASTM F-894. For direct buried pipe, the

minimum bell thickness shall equal the minimum bell thickness specified in Table 1 of ASTM F-894.

7. Pipe Length - The standard laying length for pipes up through seventy-two inches (72") diameter shall be twenty feet (20') +/- two inches (2") and the standard laying length for pipes greater than seventy-two inches (72") diameter shall be nineteen feet (19'). +/- two inches (2").
8. RSC and Flattening - The minimum RSC values for the pipe is ninety percent (90%) of the nominal class value when tested in accordance with Section 8.5 of ASTM F-894. There shall be no evidence of splitting, cracking, or breaking when the pipe is flattened to forty percent (40%) of its original diameter in accordance with Section 8.6 of ASTM F-894. Sample size for RSC and flattening tests shall be one (1) sample per size and class of pipe.
9. Marking - Each length of pipe shall be clearly marked with the ASTM F-894 designation, the nominal pipe size, the RSC class, material cell classification, and the manufacturer's name and production code.
10. Qualification - The manufacturer shall have at least ten (10) years of experience manufacturing profile wall PE pipes for the U.S. market.
11. HDPE Manholes and HDPE fittings - The same manufacturer shall manufacture HDPE pipe, HDPE manholes, and HDPE fittings. Manholes shall be made to ASTM F-1759. Manhole risers shall be constructed from solid wall pipe.
12. Certification - As the basis of acceptance of the material, the manufacturer shall furnish a certificate of conformance to these Specifications upon request.

**71-2.052 Reworked Material** - In lieu of virgin PE, the manufacturer may use clean reworked material, provided that it meets the cell classification.

**71-2.053 Installation and Field Inspection** - Pipes shall be bedded and backfilled in conformance with Section 19-4, "*Open Trench Operations*" of these Standard Specifications.

**71-2.06 Polyethylene (PE) Solid Wall Pipe** - Polyethylene (PE) plastic solid wall pipe for use in gravity flow sanitary sewers, storm drains, and house connection sewers shall comply with ASTM D-3350 or ASTM F-714. Unless otherwise indicated, pipes shall conform to SDR 26. Fittings shall comply with ASTM D-2683 or D-3261.

**71-2.061 Material Composition** - Pipes and fittings shall be made from PE resins complying with ASTM D-1248, Type III, Class C, Category 5, Grade P34, and ASTM D-3350, and which shall further meet the requirements as listed in the following table:

**TABLE 71-2.061 (A)**

<u>PROPERTY</u>	<u>VALUE</u>	<u>ASTM TEST</u>
Density <i>lb/in<sup>3</sup></i>	0.0343	D-1505
Melt Index [ <i>oz/10 minutes</i> ]	0.00529 max.	D-1238 cond. E.
Flexural Modulus psi	120,000 min.	D-790
Tensile strength at yield psi	3,200 min.	D-638
Elongation at break (%)	800	D-638
Brittleness temperature °F	-180 max.	D-746
Environmental Stress Crack Resistance F <sub>0</sub> (hrs.) <sup>1</sup>	192 min.	D-1693
Test Condition "C"		
Hydrostatic Design Basic psi @ 73°F	1600 psi	D-2837
Color	2% Carbon Black min.	

1. F<sub>0</sub> indicates no failures.

Additives and fillers including, but not limited to, stabilizers, antioxidants, lubricants, colorants, etc., shall not exceed five (5) parts by weight per one hundred (100) of PE resin in the compound. The City Engineer may require certification by the manufacturer that the test results comply with Specification requirements.

**71-2.062 Pipe Acceptance** - At the time of manufacture, each lot of pipe, liner, and fittings shall be inspected for defects and tested for Elevated Temperature Sustain Pressure in accordance with ASTM F-714. Installation time limit shall conform to Section 71-2.025.

At the time of delivery, the pipe shall be homogeneous throughout, uniform in color, free of cracks, holes, foreign materials, blisters, or deleterious faults.

For testing purposes, a production lot shall consist of all pipes having the same marking number. It shall include any and all items produced during any given work shift and shall be so identified as opposed to previous or ensuing production.

**71-2.063 Chemical Resistance and Physical Testing** - PE resins furnished under this subsection shall conform to Section 71-2.021, except that the following values are substituted.

**TABLE 71-2.063 (A)**

<u>PROPERTY</u>	<u>ASTM TEST METHOD</u>	<u>INITIAL VALUE</u>	<u>VALUE AFTER 112 DAYS EXPOSURE</u>
Tensile Strength psi min	D-638	3,200	3,200
Impact Strength	D-256	3.5	3.5
Foot-Pounds/Inch min.	Method A 3.5 Size 1/2"x1/8"x2 1/2"		
Weight Change %	D-543		
Unconditioned			± 1.5 max.
Conditioned			± 1.0 max.

The City Engineer may, at any time, direct the manufacturer to obtain compound samples and to obtain compression molded test specimens in accordance with ASTM D-1928. These specimens shall comply with the minimum property values shown above.

**71-2.064 Installation and Field Inspection** - Pipes shall be bedded and backfilled in conformance with Section 19-4, "*Open Trench Operations*" of these Standard Specifications.

**71-2.07 Ductile Iron Pipe (DIP) and Fittings** - Ductile iron pipe and fittings shall conform to the Specifications of ASTM Designation A-377. Unless otherwise approved by the City Engineer, DIP shall be used in lieu of cast iron pipe (CIP).

Above ground or exposed joints shall be flanged.

Underground joints shall be mechanical or bell and socket and approved by the City Engineer.

**71-2.08 Miscellaneous Iron and Steel** - Miscellaneous iron and steel shall conform to the Provisions of Section 75, "*Miscellaneous Metal*."

All steel items shall be galvanized. All cast iron items shall be painted or dipped in commercial quality, asphalt paint furnished by the Contractor. Galvanized shall be performed after fabrication.

Frames and covers shall be match-marked in pairs before delivery to the work and the covers shall fit into their frames without racking. The faces and seats of manhole covers shall be machined finished.

**71-2.09 Manholes** - New manholes shall conform to Section 70-1.02H of the State Standard Specifications and constructed in accordance with the Standard Plans and at the locations shown on the Plans. Steps shall not be installed in manholes and pipe may be laid through the manhole and be used as the channel. Concrete manholes for sanitary sewers shall be completely coated inside with fiberglass liner with United Coatings Elastuff 120. Elastuff Hydrophobic Polyurethane Elastomer with Uni-Tile Sealer, Raven 405 one hundred percent (100%) solid epoxy, or approved equal by the City Engineer. Coating shall include all concrete interiors from flowline to manhole cover. Existing manholes shall be adjusted to grade, re-modeled, or abandoned as shown on the Plans or in accordance with the Provisions of Section 15-2.05A and



the Standard Plans. Existing sanitary sewer manhole to be reused that has not been coated shall be cleaned and completely coated inside with Lafarge Sewper Coat calcium aluminate cements and aggregates or approved equal by the City Engineer.

**71-2.10 Guide Specification for HDPE Manholes** - Pipe shall be bedded and backfilled in conformance with Section 19 -4, “*Open Trench Operations*” of these Standard Specifications.

**71-2.101 General** - This guide Specification covers the requirements of High Density Polyethylene manholes in nominal sizes of thirty-six inches (36”) to one hundred-twenty inches (120”).

A. Definitions:

Under this standard, the following definitions apply:

1. Purchaser - The person, firm, corporation, or government agency engaging in a Contract or agreement to purchase pipe according to this Standard.
2. Inspectors - The authorized representatives of the purchaser entrusted with the duty of inspecting pipe produced and witnessing tests performed under these Standards. The Contractor representative and the City of Salinas’ representative are the authorized inspectors.
3. Inspection - Pipe inspection and the tests by manufacturer under observation of the purchaser inspectors.

**71-2.102 - Materials:**

- A. Base Materials - The riser shaft, top, base, and stub out pipes shall be made of PE plastic compound meeting the requirements of cell classification 335444C or higher as defined in ASTM D-3350 Standard Specification for Polyethylene Plastics Pipe and Fittings Materials. The Manufacturer shall certify that the materials used to manufacture manholes meet these requirements. White or other colored pigments may be added to the base resin provided Purchaser and Manufacturer agree to such formulations. Exception shall be that Rota molded cones shall be made of medium density polyethylene.
- B. Other Materials - Materials other than those specified under base materials may be used as part of the profile construction, for example, as a core tube to support the shape of the profile during processing, provided these materials are compatible with the base PE material. Examples of suitable materials include polyethylene and polypropylene.
- C. Rework materials - Clean rework material of the type described in Section 71-2.102.A or this Section and generated from the manufacturer’s own production, may be used provided the material is of the same cell classification as the base PE material and allows the manufacturing of manhole risers that meets all the requirements of this Specification.

- D. Gaskets - Rubber gaskets shall comply in all respects with the physical requirements specified in the non-pressure requirements of ASTM F-477.
- E. Lubricant - The lubricant used for assembly of gasket joints shall have no detrimental effect on the gasket or on the pipe.

**71-2.103 Manufacturer's Quality Control:**

- A. The pipe and fitting manufacturer shall have an established quality control program responsible for inspecting incoming and outgoing materials. At a minimum, incoming polyethylene materials shall be inspected for density per ASTM D-1505, melt flow rate per ASTM D-1238, and contamination. The resin supplier shall certify all incoming polyethylene materials. The Manufacturer shall verify certification and approve incoming materials before processing into finished goods.

**71-2.104 - Requirements:**

A. Manhole Fabrication:

- 1. The manhole shall be fabricated to meet the design requirements of ASTM F-1759, "Standard Practice for Design of High-Density Polyethylene (HDPE) Manholes for Subsurface Applications" based on soil and installation information supplied by the Purchaser or the City Engineer.
- 2. Riser Shaft: The riser shaft shall be manufactured in accordance with ASTM F-894, shall be of solid wall construction only, and shall be specified by the Standard Inside-Diameter Dimension Ratio (SIDR) or the Inside-Dimension Ratio (IDR). The riser SIDR or IDR shall be of a sufficient wall thickness that the manhole meets the requirements of Section 71-2.104.A.1.
- 3. Joints: Where required, the manhole riser shall be manufactured with an integrally wound bell and spigot joint, an extrusion welded joint, or a fused joint. Joining shall be accomplished in accordance with the manufacturer's recommendations.

B. Shop Drawings:

- 1. Upon request complete shop drawings of the manholes shall be submitted to the City Engineer for approval.

C. Workmanship:

- 1. The riser and stub out pipes shall be homogeneous throughout and free from visible cracks, holes, foreign inclusions or other injurious defects.

D. Pipe Manufacturers:

- 1. The same manufacturer shall produce PE pipes and manholes.

## **71-2.105 - Inspection and Testing:**

### **A. Inspection Requirements:**

1. Access - The inspector shall have free access to the inspection area of the manufacturer's plant.
2. Testing - All manholes shall be hydrostatically tested unless otherwise agreed to by the Manufacturer and Purchaser.
3. Certification - As the basis of the acceptance of the material, the manufacturer shall furnish a certificate of conformance to these Specifications upon request. When prior agreement is being made in writing between the purchaser and the manufacturer, the manufacturer shall furnish other conformance certification in the form of affidavit of conformance, test results, or copies of test reports.

## **71-2.106 - Installation :**

1. Unloading - Manholes can be unloaded from the truck by using a boom and sling arrangement. Manholes shall be handled per the manufacturer's written recommendations. The manufacturer shall provide lifting lugs to assist with handling unless otherwise agreed to by the manufacturer and purchaser.
2. Installation - Achieve stable and permanent support under and around the manhole. Install the manhole in a dry trench. To provide a stable foundation place sufficient crushed stone or other Class I. The thickness of the foundation layer shall be a minimum of eight inches (8"). Compact the foundation material to ninety-five percent (95%) Standard Proctor density. Alternatively, the manhole can be set on a properly designed reinforced concrete slab on a stable foundation.
  - a. Backfilling - The embedment surrounding the manhole shall extend to at least three and one-half feet (3.5') or to the trench wall, whichever is the greater distance, for manholes placed in stable insitu soils. In unstable soil, the embedment shall extend to a distance equal to at least one (1) manhole diameter, but not less than three and one-half feet (3.5'), or to the trench wall, whichever is the greater distance. Embedment shall be placed from the invert to the top of the manhole. The embedment shall consist of Class I material or II compacted to at least ninety percent (90%) Standard Proctor density in twelve inch (12") lifts. To prevent moving the manhole out of alignment place backfill evenly around the manhole.
3. Concrete Anchors - Where required to prevent flotation, concrete anchors shall be constructed as shown in the City Engineer's design drawings.
4. Concrete Tops - When vehicular loads are present, a concrete top shall be constructed as shown in the City Engineer's design drawings.
5. Manhole Entry - Manholes present confined space and fall hazards. All entrants shall follow applicable OSHA confined space entry procedures and use a fall protection device for all entries.

### **71-2.107 - Delivery:**

6.1.1. Manholes and fittings shall, unless otherwise specified, be prepared for standard commercial shipment and shipped to project site.

**71-2.11 Pipe Laying** - Pipe laying and trench excavation shall be in accordance with Section 19-4 and as herein provided:

When the new facilities interfere with the existing flow of sewage, the Contractor shall provide satisfactory bypass facilities at his/her expense.

Unless otherwise indicated on the drawings or permitted by the City Engineer, excavation for sewers shall be by open cut.

All joints shall be cleaned and lubricated immediately prior to installation. All joints shall be mechanical joints, using pre-molded gaskets, attached to the pipes at the factory, except where other type joints are specifically approved by the City Engineer or required in the Special Provisions. All joints shall be watertight against leakage and infiltration under all conditions of expansion, contraction, and settlement.

Whenever the work ceases for any reason, the end of the pipe shall be securely closed by a tight fitting plug or wall of Class 3B (Section 90-1.01 of the Standard Specifications) concrete not less than one-half foot (0.5') thick, or by a tight brick wall sixty-seven hundredths foot (0.67') thick with cement mortar joints.

When connections are to be made to any existing pipe, conduit, or other appurtenances, the actual elevation or position of which cannot be determined without excavation, the Contractor shall excavate for, and expose, the existing improvement before laying any pipe or conduit. The City Engineer shall be given the opportunity to inspect the existing pipe before connection is made.

Where ground water occurs, the bottom of the trench shall be kept entirely free of water during the pipe laying, filling of the joints, and as long thereafter as directed by the City Engineer. The Contractor shall furnish, install, and operate all necessary machinery, appliances and equipment to keep excavations reasonably free from water during construction, and shall dispose of water so as not to cause injury to public or private property, or to cause a nuisance or menace to the public. He/she shall at all times have on hand sufficient pumping equipment and machinery, in good working condition, for all ordinary emergencies, and shall have available at all times competent mechanics for the operations of all pumping equipment. During placement of concrete, and until concrete has set, the excavation shall be kept free of water.

**71-2.12 Trench Resurfacing** - Trenches shall be resurfaced as shown on the Standard Plans.

The Contractor shall proceed immediately to resurface with temporary pavement any part of the excavation subject to heavy traffic upon notice from the City Engineer without waiting for completion of the full length of the sewer.

**71-3 Testing of Sewers** - Unless specifically waived by the City Engineer, all pipe installations shall be tested in accordance with this Section 71-3.

**71-3.01 Mandrel Testing of Plastic Pipe and Fittings** - Installed pipe shall be tested to ensure that vertical deflections for plastic pipe do not exceed the maximum allowable deflection. Maximum allowable deflections shall be governed by the mandrel requirements stated herein and shall nominally be:

1. Three percent (3%) of the maximum average ID for ABS or PVC Composite Pipe.
2. For all plastic pipe other than ABS or PVC Composite Pipe, the percentage listed of the maximum average ID shall be as follows:

**TABLE 71-2.131 (A)**  
**NOMINAL PIPE SIZE**

<b><u>Inches</u></b>	<b><u>PERCENTAGE DEFLECTION ALLOWED<sup>1</sup></u></b>
Up to and including 12	5.0
Over 12 - to and including 30	5.0
Over 30 - to and including 60	5.0
Over 60 - to and including 90	4.0
Over 90 - to and including 120	3.0
Over 120	2.5

1. Thirty (30) calendar days after installation.

The maximum average ID shall be equal to the average OD per applicable ASTM Standard minus two (2) minimum wall thicknesses per applicable ASTM Standards. Manufacturing and other tolerances shall not be considered for determining maximum allowable deflections.

Deflection test shall be performed no sooner than thirty (30) calendar days after completion of placement and densification of backfill. The pipe shall be cleaned and inspected for offsets and obstructions prior to testing.

For all pipes twenty-four inches (24") ID or smaller, a mandrel shall be pulled through the pipe by hand to ensure that maximum allowable deflections have not been exceeded. Prior to use, the mandrel shall be certified by the City Engineer or by another entity approved by the City Engineer. Use of an uncertified mandrel or a mandrel altered or modified after certification shall invalidate the test. If the mandrel fails to pass, the pipe deemed to be over deflected.

Unless otherwise permitted by the City Engineer, any over deflected pipe shall be uncovered and, if not damaged, reinstalled. Damaged pipe shall not be reinstalled, but shall be removed from the work site by the end of the work day. Any pipe subjected to any method or process other than removal, which attempts, even successfully, to reduce or cure any over deflection, shall be uncovered, removed from the Work site, and replaced with new pipe.

The mandrel shall:

- a. Be a rigid, nonadjustable, odd-numbered-leg (nine (9) legs minimum) mandrel having an effective length not less than its nominal diameter.

b. Have a minimum diameter at any point along the full length as follows:

**TABLE 71-2.131 (B)**

<u>PIPE MATERIAL</u>	<u>NOMINAL SIZE</u>	<u>MINIMUM MANDREL DIAMETER<sup>1</sup></u>
	<u>Inches</u>	<u>Inches</u>
PVC-ASTM D-3034 (SDR 26)	6	5.503
	8	7.366
	10	9.207
	12	10.961
	15	13.559
PVC-ASTM F-679 (T-1 Wall)	18	16.924
	21	19.952
	24	22.446
	27	25.297
	30	28.502
ABS OR PVC Composite Pipe ASTM D-2680	6	5.636
	8	7.663
	10	9.584
	12	11.475
	15	14.356
CCFRPM ASTM D-3262  46 psi	12	11.475
	18	17.380
	20	19.661
	24	23.527
	30	29.229
	36	35.403

1. *Metric* mandrel diameters are direct conversions of mandrel diameters in U.S. Standard Measures. If and when the above types of pipe are available and specified by the appropriate ASTM in *metric* dimensions, the primary measure, the City Engineer shall determine the appropriate mandrel diameter per the requirements of this subsection.

3. Be fabricated of steel, be fitted with pulling rings at each end, be stamped or engraved on some segment other than a runner indicating the pipe material Specification, nominal size, and mandrel OD (e.g., PVC D3034-8"-7.366"; ABS Composite D2680-10"-9.584"); and be furnished in a suitable carrying case labeled with the same data as stamped or engraved on the mandrel.

The maximum average IDs shall be measured in the field prior to installation. For pipe ID's nominally greater than twenty-four inches (24") to thirty-six inches (36"), deflections shall be determined by a method submitted to and approved by the City Engineer. If a mandrel is selected, the minimum diameter, length and other requirements shall conform to the dimensions and

requirements as stated above. Deflection measurement for ID's nominally larger than thirty-six inches (36") shall be determined using a one inch (1") diameter rigid, Agency-certified, nonadjustable metal bar; a minimum-radius rigid template; or by a method approved by the City Engineer.

All costs incurred by the Contractor attributable to mandrel and deflection testing, including any delays shall be considered as included in the prices paid for in the various items of work, and no additional compensation shall be allowed therefore.

**71-3.02 Air Pressure Testing** - Unless otherwise provided on the Plans or in the Specifications, the Contractor shall furnish all materials, equipment, and labor for making an air test and for cleaning the pipeline in advance of the air test. The City Engineer shall approve air test equipment.

The Contractor shall furnish an inflatable rubber ball of a size that shall inflate to fit snugly into the pipe to be tested. The ball may, at the option of the Contractor, be used without a tag line, or a rope, or cord may be fastened to the ball to enable the Contractor to know and control its position at all times. The ball shall be placed in the last cleanout or manhole on the pipe to be cleaned, and water shall be introduced behind it. The ball shall pass through the pipe with only the force of the water impelling it. All debris flushed out ahead of the ball shall be removed at the first manhole where its presence is noted. In the event cemented or wedged debris, or a damaged pipe shall stop the ball, the Contractor shall remove the obstruction.

At his/her option the Contractor may conduct an initial air test of the sewer mainline after densification of the backfill, but prior to installation of the house connection sewers. Such tests shall be considered to be for the Contractor's convenience and need not be performed in the presence of the City Engineer.

Each section of sewer shall be tested between successive manholes by plugging and bracing all openings in the sewer mainline and the upper ends of all house connection sewers. Prior to any air pressure testing, all pipe plugs shall be checked with a soap solution to detect any air leakage. If any leaks are found, the air pressure shall be released, the leaks eliminated, and the test procedure started over again.

The Contractor shall furnish a calibrated ten psi (10 psi) to twelve psi (12 psi) gage with each psi divided into fourths (1/4). The final air leakage test of the sewer mainline and branching house connection sewers shall be conducted in the presence of the City Engineer in the following manner:

Air shall be introduced into the pipeline until four psi (4 psi) gage pressure has been reached, at which time the flow of air shall be reduced and the internal air pressure shall be maintained between three and one-half psi (3.5 psi) and four and one-half psi (4.5 psi) gage pressure for at least two (2) minutes to allow the air temperature to come to equilibrium with the temperature of the pipe walls. Pressure in the pipeline shall be constantly monitored by a gage and hose arrangement separate from hose used to introduce air into the line. Pressure in the pipeline shall not be allowed to exceed five psi (5 psi) gage pressure.

After the temperature has stabilized and no air leaks at the plugs have been found, the air pressure shall be permitted to drop and, when the internal pressure has reached three and one-half psi (3.5 psi) gage pressure, a stopwatch or sweep-second-hand watch shall be used to

determine the time lapse required for the air pressure to drop to two and one-half psi 2.5 psi gauge pressure.

If the time lapse (in seconds) required for the air pressure to decrease from three and one-half psi 3.5 psi to two and one-half psi 2.5 psi gage pressure exceeds that shown in the Air Tables (A) of Section 71-3.02, the pipe shall be presumed to be within acceptance limits for leakage.

If the time lapse is less than that shown in the table, the Contractor shall at his/her expense determine the source or sources of the leakage, and repair or replace all defective materials or workmanship. The completed pipe installation shall meet the requirements of this test.

### SECTION 71-3.02 (A) AIR TABLES

#### Minimum holding time in seconds required for pressure drop from 3.5 psi to 2.5 psi

		PIPE DIAMETER													
		4"	6"	8"	10"	12"	15"	18"	21"	24"	27"	30"	33"	36"	39"
LENGTH OF LINE IN FEET	25	4	10	18	28	40	62	89	121	158	200	248	299	356	418
	50	9	20	35	55	79	124	178	241	317	401	495	599	713	837
	75	13	30	51	83	119	186	207	364	475	601	743	898	1020	1105
	100	18	40	70	110	158	248	356	485	614	765	851	935		
	125	22	50	88	138	198	309	446	595	680					
	150	26	59	106	165	218	371	510							
	175	31	69	121	193	277	425								
	200	35	79	141	220	317									
	225	40	89	158	248	340									
	250	44	99	176	275										
	275	48	109	194	283										
	300	53	119	211											
	350	62	139	227											
	400	70	158												
	450	79	170												
	500	88													
	550	97													
	600	106													
	650	113	170	227	283	340	425	510	595	680	765	851	935	1020	1105

Note: To be used when testing one (1) diameter only.



LENGTH OF MAIN LINE IN FEET 6" DIAMETER															
LENGTH OF LATERAL IN FEET 4" DIAMETER		25	50	75	100	125	150	175	200	225	250	275	300	400	500
	25	14	24	34	44	54	64	74	84	94	103	113	123	163	168
	50	19	29	39	48	58	68	78	88	98	108	118	128	166	167
	75	23	33	43	53	63	73	83	92	102	112	122	132	164	165
	100	28	37	47	57	67	77	87	97	107	117	127	136	162	163
	125	32	42	52	62	72	81	91	101	111	121	131	141	160	162
	150	36	46	56	66	76	86	96	106	116	125	135	145	159	161
	175	41	51	61	70	80	90	100	110	120	130	140	150	157	159
	200	45	55	65	75	85	95	105	114	124	134	144	153	156	158
	225	50	59	69	79	89	99	109	119	129	139	149	151	154	157
	250	54	64	74	84	94	103	113	123	133	143	149	150	153	156
	275	58	68	78	88	98	108	118	128	138	146	147	149	152	155
	300	63	73	83	92	102	112	122	132	142	145	146	147	151	154
350	72	81	91	101	111	121	131	140	141	143	144	145	149	152	
400	80	90	100	110	120	130	136	138	139	141	142	143	147	150	
450	89	99	109	119	129	132	134	136	138	139	141	142	145	149	
500	98	108	118	126	129	131	133	135	136	138	139	140	144	147	

LENGTH OF MAIN LINE IN FEET 8" DIAMETER															
LENGTH OF LATERAL IN FEET 4" DIAMETER		25	50	75	100	125	150	175	200	225	250	275	300	400	500
	25	22	40	57	75	92	110	128	145	163	180	198	216	223	224
	50	26	44	62	79	97	114	132	150	167	185	202	218	220	221
	75	31	48	66	84	101	119	136	154	172	189	207	214	217	219
	100	35	53	70	88	106	123	141	158	176	194	209	211	214	216
	125	40	57	75	92	110	128	145	163	180	198	206	207	211	214
	150	44	62	79	97	114	132	150	167	185	201	202	204	209	212
	175	48	66	84	101	119	136	154	172	189	197	199	201	206	210
	200	53	70	88	106	123	141	158	176	192	194	197	199	204	208
	225	57	75	92	110	128	145	163	180	189	192	194	196	202	206
	250	62	79	97	114	132	150	167	183	186	189	191	193	200	204
	275	66	84	101	119	136	154	172	181	184	187	189	191	198	202
	300	70	88	106	123	141	158	174	178	181	184	187	189	196	200
350	79	97	114	132	150	166	170	174	177	180	183	185	192	197	
400	88	106	123	141	157	162	166	166	174	176	179	181	189	194	
450	97	114	132	148	154	159	163	167	170	173	176	178	186	191	
500	106	123	140	146	151	156	160	164	167	170	173	175	183	189	

<b>LENGTH OF MAIN LINE IN FEET 8" DIAMETER</b>															
<b>LENGTH OF LATERAL IN FEET 6" DIAMETER</b>		<b>25</b>	<b>50</b>	<b>75</b>	<b>100</b>	<b>125</b>	<b>150</b>	<b>175</b>	<b>200</b>	<b>225</b>	<b>250</b>	<b>275</b>	<b>300</b>	<b>400</b>	<b>500</b>
	<b>25</b>	28	45	63	80	98	116	133	151	168	186	204	221	224	225
	<b>50</b>	37	55	73	90	108	126	143	161	178	196	214	220	222	223
	<b>75</b>	47	65	83	100	118	135	153	171	188	206	217	217	220	221
	<b>100</b>	57	75	93	110	128	145	163	181	198	214	214	215	218	220
	<b>125</b>	67	85	102	120	138	155	173	190	208	211	212	213	216	218
	<b>150</b>	77	95	112	130	148	165	182	200	207	209	210	211	214	217
	<b>175</b>	87	105	122	140	157	175	192	204	206	207	208	209	213	215
	<b>200</b>	97	114	132	150	167	185	201	202	204	205	206	207	211	214
	<b>225</b>	107	124	142	160	177	195	199	201	203	204	205	206	210	213
	<b>250</b>	117	134	152	169	187	195	198	199	201	202	203	204	209	212
	<b>275</b>	127	144	162	179	192	194	196	198	200	201	202	204	208	210
	<b>300</b>	136	154	172	187	190	192	195	196	198	200	201	202	207	209
<b>350</b>	156	174	181	185	187	190	193	194	196	198	199	200	205	208	
<b>400</b>	173	178	181	184	186	189	191	192	194	196	197	198	203	206	
<b>450</b>	173	177	180	183	185	187	189	190	192	194	195	196	201	204	
<b>500</b>	173	177	180	182	184	186	188	189	191	192	193	194	200	203	

<b>LENGTH OF MAIN LINE IN FEET 10" DIAMETER</b>															
<b>LENGTH OF LATERAL IN FEET 4" DIAMETER</b>		<b>25</b>	<b>50</b>	<b>75</b>	<b>100</b>	<b>125</b>	<b>150</b>	<b>175</b>	<b>200</b>	<b>225</b>	<b>250</b>	<b>275</b>	<b>300</b>	<b>400</b>	<b>500</b>
	<b>25</b>	32	59	87	114	142	169	197	224	252	277	277	278	279	280
	<b>50</b>	36	64	91	119	146	174	201	229	256	271	272	273	275	277
	<b>75</b>	41	68	96	123	151	178	206	233	261	265	267	268	272	274
	<b>100</b>	45	73	100	128	155	183	210	238	258	260	262	264	268	271
	<b>125</b>	50	77	105	132	160	187	214	242	253	255	257	259	264	268
	<b>150</b>	54	81	109	136	164	191	219	244	248	251	253	255	261	265
	<b>175</b>	58	86	113	141	168	196	223	239	243	246	249	251	258	262
	<b>200</b>	63	90	118	145	173	200	228	235	239	242	245	248	255	260
	<b>225</b>	67	95	122	150	177	205	226	231	235	239	242	244	252	257
	<b>250</b>	72	99	127	154	182	209	222	227	231	235	238	241	249	255
	<b>275</b>	76	103	131	158	186	211	218	223	228	231	235	238	247	253
	<b>300</b>	80	108	135	163	190	208	214	220	274	228	232	235	244	250
<b>350</b>	89	117	144	172	194	201	208	213	218	222	226	229	239	246	
<b>400</b>	98	125	153	179	188	196	202	208	213	217	221	224	235	242	
<b>450</b>	107	134	162	174	183	191	197	203	208	212	216	220	230	238	
<b>500</b>	116	143	160	170	179	186	193	198	203	208	212	215	226	235	

LENGTH OF MAIN LINE IN FEET 10" DIAMETER															
LENGTH OF LATERAL IN FEET 6" DIAMETER		25	50	75	100	125	150	175	200	225	250	275	300	400	500
	25	37	65	92	120	147	175	202	230	257	277	278	278	279	280
	50	47	75	102	130	157	185	212	240	267	271	272	273	276	277
	75	57	85	112	140	167	195	222	250	265	266	267	269	272	274
	100	67	95	122	150	177	205	232	257	260	262	263	265	269	271
	125	77	105	132	160	187	215	242	253	255	257	259	261	266	269
	150	87	114	142	169	197	224	245	248	251	254	256	257	263	266
	175	97	124	152	179	207	234	241	245	248	250	252	254	260	264
	200	107	134	162	189	217	233	237	241	244	247	249	251	258	262
	225	117	144	172	199	225	230	234	238	241	244	246	248	255	260
	250	127	154	182	209	222	227	231	235	238	241	243	246	253	258
	275	136	164	191	213	219	224	229	232	236	238	241	243	251	256
	300	146	174	201	211	217	222	226	230	233	236	239	241	249	254
350	166	192	200	207	212	217	222	226	229	232	235	237	245	250	
400	181	190	197	203	209	214	218	222	225	228	231	233	241	247	
450	180	188	195	201	206	211	215	218	222	225	227	230	238	244	
500	179	186	193	198	203	208	212	215	219	222	224	227	235	241	

LENGTH OF MAIN LINE IN FEET 10" DIAMETER															
LENGTH OF LATERAL IN FEET 8" DIAMETER		25	50	75	100	125	150	175	200	225	250	275	300	400	500
	25	45	73	100	128	155	183	210	238	265	279	280	280	281	281
	50	63	90	118	145	173	200	228	255	275	275	276	277	278	279
	75	80	108	135	163	190	218	245	270	272	272	273	274	276	277
	100	98	125	153	180	208	235	263	267	268	269	270	271	274	275
	125	116	143	171	198	226	253	263	265	266	267	268	269	272	274
	150	133	161	188	216	243	258	260	262	264	265	266	267	270	272
	175	151	178	206	233	254	256	258	260	262	263	264	265	268	271
	200	168	196	223	249	252	254	256	258	260	261	262	263	267	269
	225	186	213	241	247	250	253	255	257	258	259	261	262	265	268
	250	204	231	242	246	249	251	253	255	256	258	259	260	264	267
	275	221	237	241	244	247	250	252	254	255	256	258	259	263	266
	300	232	237	240	243	246	249	251	253	254	255	256	258	262	265
350	232	235	239	242	244	247	249	251	252	253	254	256	260	263	
400	231	234	238	240	243	245	247	249	250	251	253	254	258	261	
450	230	234	237	239	241	243	245	247	248	250	251	252	256	259	
500	230	233	236	238	240	242	244	246	247	249	250	251	255	258	

		LENGTH OF MAIN LINE IN FEET 12" DIAMETER													
LENGTH OF LATERAL IN FEET 4" DIAMETER		25	50	75	100	125	150	175	200	225	250	275	300	400	500
	25	44	84	123	163	202	242	282	321	332	333	334	334	336	336
	50	48	88	128	167	207	246	286	323	324	326	327	328	331	333
	75	53	92	132	172	211	251	290	316	317	319	321	323	327	329
	100	57	97	136	176	216	255	295	308	311	313	316	317	323	326
	125	62	101	141	180	220	260	297	301	304	308	310	312	319	323
	150	66	106	145	185	224	264	290	295	299	302	305	308	315	319
	175	70	110	150	189	229	268	283	289	293	297	300	303	311	316
	200	75	114	154	194	233	271	277	283	288	292	296	299	308	313
	225	79	119	158	198	238	265	272	278	283	288	291	295	304	310
	250	84	123	163	202	242	259	267	273	278	283	287	291	301	308
	275	88	128	167	207	244	254	262	269	274	279	283	287	298	305
	300	92	132	172	211	239	249	257	264	270	275	279	283	295	302
	350	101	141	180	218	231	241	249	256	262	268	272	276	289	297
400	110	150	189	210	223	233	242	249	255	261	266	270	283	292	
450	119	158	189	204	216	227	235	243	249	255	260	264	278	288	
500	128	166	184	198	210	221	229	237	243	249	254	259	273	283	

		LENGTH OF MAIN LINE IN FEET 12" DIAMETER													
LENGTH OF LATERAL IN FEET 6" DIAMETER		25	50	75	100	125	150	175	200	225	250	275	300	400	500
	25	50	89	129	168	208	248	287	327	331	332	333	333	335	336
	50	59	99	139	178	218	257	297	321	323	325	326	327	330	332
	75	69	109	149	188	228	267	307	314	316	318	320	321	326	328
	100	79	119	158	198	238	277	302	306	309	312	314	316	321	325
	125	89	129	168	208	248	287	295	300	303	306	309	311	317	321
	150	99	139	178	218	257	284	289	294	298	301	304	306	314	318
	175	109	149	188	228	267	278	284	289	293	296	299	302	310	315
	200	119	158	198	238	265	272	278	284	288	292	295	298	306	312
	225	129	168	208	248	260	268	274	279	284	288	291	294	303	309
	250	139	178	218	246	255	263	269	275	280	284	287	290	300	306
	275	149	188	228	242	251	259	266	271	276	280	284	287	297	304
	300	158	198	227	238	248	255	262	268	272	277	281	284	294	301
	350	178	208	221	232	241	249	255	261	266	271	274	278	289	296
400	189	204	217	227	236	243	250	256	261	265	269	273	284	292	
450	187	201	213	223	231	239	245	251	256	260	264	268	279	288	
500	186	199	210	219	227	234	240	246	251	256	260	263	275	284	

<b>LENGTH OF MAIN LINE IN FEET 12" DIAMETER</b>															
<b>LENGTH OF LATERAL IN FEET 8" DIAMETER</b>		<b>25</b>	<b>50</b>	<b>75</b>	<b>100</b>	<b>125</b>	<b>150</b>	<b>175</b>	<b>200</b>	<b>225</b>	<b>250</b>	<b>275</b>	<b>300</b>	<b>400</b>	<b>500</b>
	<b>25</b>	57	97	136	176	216	255	292	331	332	333	334	334	336	336
	<b>50</b>	75	114	154	194	233	273	312	324	325	327	328	329	331	333
	<b>75</b>	92	132	172	211	251	290	315	317	319	321	323	324	327	330
	<b>100</b>	110	150	189	229	268	306	309	312	314	316	318	319	324	327
	<b>125</b>	128	167	207	246	286	300	303	306	309	311	314	315	320	324
	<b>150</b>	145	185	224	264	290	295	299	302	305	307	310	311	317	321
	<b>175</b>	163	202	242	279	285	290	294	298	301	304	306	308	314	318
	<b>200</b>	180	220	260	275	281	287	291	294	297	300	303	305	312	316
	<b>225</b>	198	238	265	272	278	283	287	291	294	297	300	302	309	314
	<b>250</b>	216	253	262	269	275	280	284	288	291	294	297	299	306	311
	<b>275</b>	233	251	260	266	272	277	282	285	289	292	294	297	304	309
	<b>300</b>	240	249	258	264	270	275	279	283	286	289	292	294	302	307
<b>350</b>	238	247	254	260	266	271	275	279	282	285	288	290	298	304	
<b>400</b>	237	245	252	257	263	267	271	275	278	281	284	286	294	300	
<b>450</b>	236	243	249	255	260	264	268	272	275	278	281	283	291	297	
<b>500</b>	235	242	248	253	257	262	265	269	272	275	278	280	288	295	

<b>LENGTH OF MAIN LINE IN FEET 15" DIAMETER</b>															
<b>LENGTH OF LATERAL IN FEET 4" DIAMETER</b>		<b>25</b>	<b>50</b>	<b>75</b>	<b>100</b>	<b>125</b>	<b>150</b>	<b>175</b>	<b>200</b>	<b>225</b>	<b>250</b>	<b>275</b>	<b>300</b>	<b>400</b>	<b>500</b>
	<b>25</b>	66	128	190	252	314	376	414	415	416	417	418	418	420	421
	<b>50</b>	71	133	194	256	318	380	403	406	408	409	411	412	415	417
	<b>75</b>	75	137	199	261	323	385	393	397	400	402	404	406	410	413
	<b>100</b>	80	141	203	265	327	378	384	388	392	395	397	400	406	409
	<b>125</b>	84	146	208	270	331	369	375	380	385	388	391	394	401	406
	<b>150</b>	88	150	212	274	336	360	367	373	378	382	385	388	397	402
	<b>175</b>	93	155	216	278	340	351	359	366	371	376	380	383	392	398
	<b>200</b>	97	159	221	283	332	343	352	359	365	370	374	378	388	395
	<b>225</b>	102	163	225	287	324	336	345	353	359	365	369	373	384	392
	<b>250</b>	106	168	230	292	317	329	339	347	353	359	364	368	380	388
	<b>275</b>	110	172	234	293	310	323	333	341	348	354	359	364	377	385
	<b>300</b>	115	177	238	287	303	316	327	336	343	349	354	359	373	382
<b>350</b>	124	185	247	275	292	305	316	325	333	340	346	351	366	376	
<b>400</b>	132	194	242	264	281	292	306	316	324	332	338	343	359	370	
<b>450</b>	141	203	233	255	272	286	298	308	316	324	330	336	353	365	
<b>500</b>	150	199	225	247	264	278	290	300	309	316	323	329	347	359	

LENGTH OF MAIN LINE IN FEET 15" DIAMETER															
LENGTH OF LATERAL IN FEET 6" DIAMETER		25	50	75	100	125	150	175	200	225	250	275	300	400	500
	25	72	134	196	257	319	381	411	413	414	416	416	417	419	420
	50	82	144	205	267	329	391	399	402	404	406	408	409	413	415
	75	92	154	215	277	339	383	388	392	395	398	400	402	408	411
	100	102	163	225	287	349	372	378	383	387	390	393	395	402	406
	125	111	173	235	297	352	362	369	374	379	383	386	389	397	402
	150	121	183	245	307	342	352	360	367	372	376	380	383	392	398
	175	131	193	255	317	334	344	353	360	365	370	374	377	387	394
	200	141	203	265	312	326	337	346	353	359	364	368	372	383	390
	225	151	213	275	304	319	330	339	346	353	358	363	367	379	387
	250	161	223	279	298	312	323	333	341	347	353	358	362	374	383
	275	171	233	273	292	306	317	327	335	342	348	353	357	370	379
	300	181	243	268	286	300	312	322	330	337	343	349	353	367	376
350	201	237	259	277	291	302	312	321	328	334	339	344	359	370	
400	204	231	252	268	282	294	304	312	320	326	332	337	353	364	
450	201	226	245	261	275	286	296	305	312	319	325	330	346	358	
500	199	221	240	255	269	280	290	298	306	312	318	324	341	353	

LENGTH OF MAIN LINE IN FEET 15" DIAMETER															
LENGTH OF LATERAL IN FEET 8" DIAMETER		25	50	75	100	125	150	175	200	225	250	275	300	400	500
	25	80	141	203	265	327	389	411	413	414	418	416	417	419	420
	50	97	159	221	283	345	395	399	402	404	408	407	409	413	415
	75	115	177	238	300	362	383	388	392	395	400	400	402	407	410
	100	132	194	256	318	366	373	378	383	387	392	393	395	402	406
	125	150	212	274	336	356	364	370	375	379	385	386	389	397	402
	150	168	229	291	337	348	356	362	368	373	379	380	383	392	398
	175	185	247	309	329	340	349	355	362	366	373	374	378	387	394
	200	203	265	309	323	334	342	349	356	361	367	369	373	383	390
	225	220	282	303	317	328	337	344	350	356	362	364	368	379	386
	250	238	281	298	311	322	331	339	345	351	357	360	364	375	383
	275	256	277	293	307	318	327	334	341	346	353	356	359	372	380
	300	254	274	290	303	313	322	330	336	342	349	352	356	368	377
350	250	269	283	296	306	315	322	329	335	341	344	349	362	371	
400	248	264	278	290	300	308	316	322	328	335	338	342	356	366	
450	246	261	274	285	294	303	310	316	322	329	332	337	351	361	
500	244	258	270	281	290	298	305	311	317	323	327	331	346	356	

		LENGTH OF MAIN LINE IN FEET 18" DIAMETER													
LENGTH OF LATERAL IN FEET 4" DIAMETER		25	50	75	100	125	150	175	200	225	250	275	300	400	500
	25	94	183	272	361	450	496	498	499	501	502	502	503	505	506
	50	98	187	276	365	454	483	487	489	492	493	495	496	499	502
	75	102	191	281	370	459	470	476	480	483	485	488	489	494	497
	100	107	196	285	374	450	459	465	470	475	478	481	483	489	493
	125	111	200	289	378	438	448	456	462	467	470	474	477	484	489
	150	116	205	294	383	427	438	446	453	459	463	467	471	480	485
	175	120	209	298	387	416	428	438	445	452	457	461	465	475	481
	200	124	213	303	388	406	419	430	438	445	450	455	459	470	478
	225	129	218	307	378	397	410	422	431	438	444	449	453	466	474
	250	133	222	311	369	388	402	414	424	431	438	443	448	462	470
	275	138	227	316	360	380	395	407	417	425	432	438	443	457	467
	300	142	231	320	352	372	387	400	411	419	426	433	438	453	463
350	151	240	308	337	358	374	388	399	408	416	422	428	445	457	
400	160	249	295	323	345	362	376	388	397	406	413	419	438	450	
450	168	246	283	312	333	351	365	378	388	396	404	411	430	444	
500	177	237	273	301	323	341	355	368	379	388	396	403	423	438	

		LENGTH OF MAIN LINE IN FEET 18" DIAMETER													
LENGTH OF LATERAL IN FEET 6" DIAMETER		25	50	75	100	125	150	175	200	225	250	275	300	400	500
	25	99	188	277	366	455	492	495	497	498	499	500	501	503	505
	50	109	198	287	376	465	476	481	484	487	489	491	493	497	499
	75	119	208	297	386	453	462	468	473	477	480	482	484	490	494
	100	129	218	307	396	439	449	456	462	467	470	474	476	484	489
	125	139	228	317	406	425	437	445	452	457	462	466	469	478	484
	150	149	238	327	397	413	426	435	443	449	454	458	462	473	480
	175	158	248	337	385	402	415	426	434	441	446	451	455	467	475
	200	168	257	347	375	392	406	417	426	433	439	444	449	462	470
	225	178	267	340	365	383	397	409	418	426	432	438	443	457	466
	250	188	277	331	356	374	389	401	411	419	426	431	437	452	462
	275	198	287	323	348	367	382	394	404	412	419	426	431	447	458
	300	208	284	316	341	359	375	387	397	406	414	420	426	443	454
350	228	272	303	328	346	362	375	385	395	403	409	415	434	446	
400	224	263	293	316	335	351	364	375	384	392	400	406	426	439	
450	219	255	284	307	325	341	354	365	375	383	391	397	418	432	
500	215	246	276	298	316	332	345	356	366	375	382	389	411	426	

LENGTH OF MAIN LINE IN FEET 18" DIAMETER															
LENGTH OF LATERAL IN FEET 8" DIAMETER		25	50	75	100	125	150	175	200	225	250	275	300	400	500
	25	107	196	285	374	463	490	493	495	497	498	499	500	503	504
	50	124	213	303	392	468	473	478	482	485	487	489	491	495	498
	75	142	231	320	409	451	458	465	469	474	477	479	482	488	492
	100	160	249	338	423	436	445	452	458	463	467	470	473	482	487
	125	177	266	355	409	423	433	442	448	454	458	462	466	475	482
	150	195	284	373	397	411	422	432	439	445	450	454	458	469	477
	175	212	301	366	386	401	413	422	430	437	442	447	451	464	472
	200	230	319	356	377	391	404	414	422	429	435	440	445	458	467
	225	248	321	348	368	384	396	406	415	422	429	434	439	453	463
	250	265	315	341	361	376	389	399	408	416	423	428	433	448	458
	275	275	309	334	354	369	382	393	402	410	417	422	428	443	454
	300	271	304	328	348	363	376	387	396	404	411	417	422	439	450
350	266	296	319	337	352	365	376	386	394	401	407	413	430	443	
400	262	289	311	329	343	356	367	376	384	392	398	404	422	436	
450	258	284	304	321	335	348	359	368	376	384	390	396	415	429	
500	255	279	298	315	328	340	351	361	369	376	383	389	409	423	

LENGTH OF MAIN LINE IN FEET 21" DIAMETER															
LENGTH OF LATERAL IN FEET 4" DIAMETER		25	50	75	100	125	150	175	200	225	250	275	300	400	500
	25	126	247	368	490	577	581	582	584	585	586	587	588	590	591
	50	130	251	373	494	561	567	570	573	576	578	579	581	584	586
	75	135	256	377	498	545	553	559	563	567	569	571	574	579	582
	100	139	260	381	503	531	541	548	553	558	561	564	567	573	578
	125	143	265	386	503	518	429	537	544	549	553	557	560	568	573
	150	148	269	390	488	505	518	527	535	541	546	550	553	563	569
	175	152	273	395	475	493	507	518	526	533	538	543	547	558	565
	200	157	278	399	462	482	497	509	518	526	531	536	541	553	561
	225	161	282	403	450	472	488	500	510	518	524	530	535	548	557
	250	165	287	408	439	462	479	492	502	511	518	524	529	544	553
	275	170	291	397	429	452	470	484	495	504	511	518	523	539	549
	300	174	295	387	420	443	462	476	488	498	505	512	518	535	546
350	183	304	368	402	427	446	462	474	485	493	501	507	526	538	
400	192	304	352	386	412	432	448	462	473	482	490	497	518	531	
450	201	291	338	372	398	419	436	450	462	472	480	488	510	524	
500	209	279	325	360	386	407	425	439	462	462	471	479	502	518	



LENGTH OF MAIN LINE IN FEET 21" DIAMETER															
LENGTH OF LATERAL IN FEET 6" DIAMETER		25	50	75	100	125	150	175	200	225	250	275	300	400	500
	25	131	253	374	495	572	576	579	581	582	584	585	586	588	589
	50	141	262	384	505	552	559	563	567	570	573	574	576	581	584
	75	151	272	394	515	533	543	549	554	559	562	565	567	574	578
	100	161	282	403	501	516	528	536	542	548	552	555	559	567	572
	125	171	292	413	483	501	514	524	531	537	542	547	550	561	567
	150	181	302	423	468	487	501	512	521	528	533	538	543	554	562
	175	191	312	425	454	474	490	501	511	518	525	530	535	548	557
	200	201	322	412	441	462	479	491	501	510	517	522	528	542	552
	225	210	332	399	429	451	468	482	492	501	509	515	521	537	547
	250	220	342	388	418	441	459	473	484	493	501	508	514	531	542
	275	230	336	378	409	432	450	464	476	486	494	501	508	526	538
	300	240	327	369	399	423	441	456	468	479	487	495	501	521	533
350	255	312	353	383	407	426	441	454	465	474	482	490	511	525	
400	246	300	339	369	393	412	428	441	453	462	471	479	501	517	
450	239	290	327	357	380	400	416	429	441	451	460	468	492	509	
500	234	281	317	346	369	389	405	419	431	441	450	459	484	501	

LENGTH OF MAIN LINE IN FEET 21" DIAMETER															
LENGTH OF LATERAL IN FEET 8" DIAMETER		25	50	75	100	125	150	175	200	225	250	275	300	400	500
	25	139	260	381	503	569	573	576	578	580	582	583	584	587	588
	50	157	278	399	520	546	554	559	563	566	569	571	573	579	582
	75	174	295	417	513	526	536	543	549	554	557	560	563	571	575
	100	192	313	434	493	508	520	529	536	542	546	550	554	563	569
	125	209	331	452	476	493	506	516	524	531	536	540	545	556	563
	150	227	348	436	461	479	493	504	513	520	526	531	536	549	557
	175	245	366	422	447	466	481	493	502	511	517	523	528	542	552
	200	262	375	409	435	455	470	483	493	502	509	515	520	536	546
	225	280	364	398	424	444	461	473	484	493	501	507	513	530	541
	250	297	355	389	415	435	451	465	476	485	493	500	506	524	536
	275	298	347	380	406	426	443	456	468	478	486	493	499	518	531
	300	293	340	372	398	418	435	449	460	470	479	486	493	513	526
350	285	328	359	384	404	421	435	447	458	466	474	481	503	517	
400	279	319	348	372	392	409	423	435	446	455	463	471	493	509	
450	274	311	338	362	381	398	413	425	435	445	453	461	484	501	
500	270	304	330	353	372	389	403	415	426	436	444	452	476	493	

		LENGTH OF MAIN LINE IN FEET 24" DIAMETER													
LENGTH OF LATERAL IN FEET 4" DIAMETER		25	50	75	100	125	150	175	200	225	250	275	300	400	500
	25	163	321	480	638	662	665	667	669	670	671	672	673	674	676
	50	167	326	484	637	645	650	654	658	660	662	664	665	669	671
	75	172	330	488	617	629	636	642	647	650	653	656	658	663	666
	100	176	334	493	599	613	623	631	637	641	645	648	650	658	662
	125	180	339	497	582	599	611	620	627	632	637	640	643	652	658
	150	185	343	502	567	585	599	609	617	623	629	633	636	647	653
	175	189	348	506	552	573	588	599	608	615	621	626	630	642	649
	200	194	352	506	538	560	577	589	599	607	613	619	623	637	645
	225	198	356	492	525	549	566	580	591	599	606	612	617	632	641
	250	202	361	478	513	538	556	571	582	591	599	605	611	627	637
	275	207	365	465	501	528	547	562	574	584	592	599	605	622	633
	300	211	370	454	491	518	538	554	567	577	585	593	599	617	629
350	220	375	432	471	499	521	538	552	563	573	581	588	608	621	
400	229	356	413	453	482	505	523	538	550	560	569	577	599	613	
450	238	340	397	436	467	491	509	525	538	549	558	566	590	606	
500	244	326	382	422	453	477	497	513	526	538	548	556	582	599	

		LENGTH OF MAIN LINE IN FEET 24" DIAMETER													
LENGTH OF LATERAL IN FEET 6" DIAMETER		25	50	75	100	125	150	175	200	225	250	275	300	400	500
	25	168	327	485	644	656	660	663	665	667	668	669	670	673	674
	50	178	337	495	624	634	641	646	651	654	656	658	660	665	668
	75	188	347	505	600	614	624	631	637	641	645	648	650	658	662
	100	198	356	515	579	596	608	617	624	630	634	638	641	650	656
	125	208	366	525	559	579	593	603	612	618	624	629	632	544	651
	150	218	376	511	542	563	579	591	600	608	614	619	624	637	645
	175	228	386	493	526	548	566	579	589	598	605	611	616	630	640
	200	238	396	477	511	535	553	567	579	588	596	602	608	624	634
	225	248	406	462	497	522	542	557	569	579	587	594	600	618	629
	250	257	397	449	485	511	531	547	559	570	579	586	593	612	624
	275	267	385	437	473	500	521	537	550	561	571	579	586	606	619
	300	277	374	426	462	490	511	528	542	553	563	571	579	600	614
350	283	356	406	443	471	493	511	526	538	549	558	566	589	605	
400	272	340	389	426	454	477	495	511	524	535	545	553	579	596	
450	263	327	375	411	439	462	481	497	511	523	533	542	569	587	
500	255	316	362	398	426	449	468	485	499	511	521	531	559	579	

		LENGTH OF MAIN LINE IN FEET 24" DIAMETER														
		25	50	75	100	125	150	175	200	225	250	275	300	400	500	
LENGTH OF LATERAL IN FEET	8" DIAMETER	25	176	334	493	645	652	656	659	662	664	666	667	668	671	673
	50	194	352	510	615	627	635	641	645	649	652	654	656	662	666	
	75	211	370	528	589	604	615	623	630	635	639	642	645	653	659	
	100	229	387	541	566	584	597	607	615	622	627	631	635	645	652	
	125	246	405	519	546	566	581	592	602	609	615	620	625	637	645	
	150	264	422	499	528	550	566	579	589	597	604	610	615	630	639	
	175	282	436	482	512	535	553	566	577	586	594	600	606	622	633	
	200	299	421	467	498	522	540	554	566	576	584	591	597	615	627	
	225	317	408	453	485	509	528	543	556	566	575	583	589	608	621	
	250	331	396	441	473	498	517	533	546	557	566	574	581	602	615	
	275	324	386	430	462	487	507	523	537	548	558	566	573	595	610	
	300	317	377	421	452	478	498	514	528	540	550	559	566	589	604	
	350	307	362	404	435	460	481	498	513	525	535	544	553	577	594	
	400	298	350	390	420	445	466	483	498	511	522	532	540	566	584	
	450	292	350	378	407	432	453	470	485	498	510	520	529	556	575	
	500	286	331	367	396	421	441	459	474	487	498	509	518	547	567	

**71-3.03 Television Inspection** - Closed circuit television (CCTV) inspection shall be required to document the condition of the pipeline and to verify that it was cleaned per Section 71-3.02 and that all laterals have been established, as required. All video inspections shall be recorded on a digital-video-disk (DVD), standard play mode that can be read by any DVD player. All original DVD's, logsheets, and reports shall be submitted to the City Engineer immediately upon completion in the field and shall become property of the City.

CCTV equipment shall include television cameras, a television monitor, cables, power sources, and other equipment. Focal distance shall be adjustable through a range from six inches (6") to infinity. The remote-reading footage counter shall be accurate to less than one percent (1%) error over the length of the particular section of pipeline being inspected. This distance is measured from the centerline of the manhole to the centerline of the next manhole or to the closed end of the pipe. The camera and television monitor shall produce a minimum 350 -lines-per-inch resolution. Telephones, radios, or other suitable means of communication shall be set up to ensure that adequate communication exists between members of the crew. The CCTV inspection system to be utilized on the project shall be approved by the City Engineer prior to the work being performed.

CCTV inspection shall be performed utilizing one (1) of the following video camera systems:

1. Remote-focus stationary lens cameras; or
2. Rotating-lens cameras; or
3. Pan-and-tilt cameras.

CCTV inspection for establishing or locating house connections or laterals shall be performed utilizing system 2 or 3 above.

The video camera shall be mounted on a skid, floatable raft system, or transporter based on the conditions of the pipeline to be televised and shall be capable of backtracking to the closed end

of the pipe.

The Contractor shall televise the pipeline during optimum low-flow level conditions, as pre-approved by the City Engineer. The television camera utilized shall be specifically designed and constructed for sewer inspection. The camera shall be operative in one hundred percent (100%) humidity conditions. Lighting for the camera shall minimize reflective glare. Lighting and picture quality shall be suitable to provide a clear, in-focus picture of the entire periphery of the pipeline for all conditions encountered during the work.

The camera shall be moved through the pipeline in a downstream direction at a uniform rate, stopping when necessary to ensure proper documentation of the sewer's condition, but in no case shall the television camera be pulled at a speed greater than thirty feet (30') per minute. If the television camera shall not pass through the entire pipeline section, the Contractor shall reset the equipment at the downstream manhole and attempt to inspect the section of pipe from the opposite direction. If the camera fails to pass through the entire section, it shall be assumed that an obstruction exists. Efforts to televise that section of pipe shall be temporarily suspended and the Contractor shall notify the City Engineer. Upon removal of the obstruction, the Contractor shall complete the CCTV inspection.

If an obstruction is encountered during the video inspection, the Contractor, at his/her expense, shall remove the obstruction by excavation, repair, or other means approved by the City Engineer in order that television inspection may continue.

Documentation shall consist of a color DVD, logsheets, and a written report detailing the condition of the pipeline and lateral connections/openings. The report shall note the time and date of video inspection, street name, upstream and downstream manhole, direction of view, direction of flow, surface material, pipeline length, pipe section length, pipe size, pipe material, lateral connections, DVD number, counter number, and a detailed logging of defects encountered. Any rejected work shall be repaired, and then re-televised. If the quality of the DVD is deemed to be unacceptable by the City Engineer, the pipeline shall be re-televised at no additional cost to the City. Additional City requirements for performing CCTV inspection shall be noted on the Plans or in the Specifications. The Contractor shall be responsible for all costs associated with furnishing television inspection and making final repairs to the sewer mains.

**71-4 Measurement** - Sewer work performed under Section 71, "Sewers", shall be designated by size, type, quality, or whatever information is necessary for identifying sewer work. The length of sewer pipe to be paid for shall be the slope length designated by the City Engineer. Pipe placed in excess of the length designated shall not be paid for. Measurement shall be to the stubs of the manhole, or inner edge of other structures to which the sewer is connected.

Pipe bends, tees, wyes and other branches shall be measured and paid for by the linear foot for the sizes of pipes involved. Bends shall be measured along the centerline to the point of intersection.

Quantities of drop manholes, offset manholes, other manholes, and flushing inlets shall be determined as units from actual count. New frames and covers shall be considered as included in the price paid for manholes and flushing inlets.

The quantity of concrete for pipe reinforcement to be paid for shall be the actual volume placed, except that the maximum width used for computing pay quantities shall be considered as two feet (2') greater than the outside diameter of the pipe.

**71-5 Payment** - Items of work, measured as specified above, shall be paid for at the Contract price per linear foot for the different sizes and types of sewer pipe; the Contract unit price for manholes and flushing inlets; the Contract price per cubic yard for Class 3 concrete (pipe reinforcement); all other items of work such as reinforcing steel, excavation and backfill, trench paving, frames and covers, testing and/or equipment and materials used for testing, including the water used for cleaning, shall be considered as included in the prices paid for in the various items of work and no additional compensation shall be allowed therefore.

Trench resurfacing shall be considered as included in the prices paid for in the various items of work, and no additional compensation shall be allowed therefore.

Reinforcement shall be considered as included in the prices paid for in the various items of work, and no additional compensation shall be allowed therefore.

Excavation and backfill shall be considered as included in the prices paid for in the various items of work, and no additional compensation shall be allowed therefore.

Full compensation for all tunneling and jacking of pipe, capping open end of pipe, joining of pipe to other pipe or structure, utility support and protective work operations required to accommodate or safeguard public traffic, testing the sewer line, and all other incidental work and material required to construct the sewer system shall be considered as included in the prices paid for in the various Contract items of sewer work and no additional compensation shall be allowed therefore.

The above prices and payments shall include full compensation for furnishing all labor, materials, tools, equipment, and incidentals, doing all the work involved for constructing sewers, complete-in-place, as shown on the Plans, specified in these Specifications, the Special Provisions, and as directed by the City Engineer.

## **SECTION 72**

### **SLOPE PROTECTION**

Slope protection shall be as specified in Section 72 of the State Standard Specifications.

## **SECTION 73**

### **CONCRETE CURBS AND SIDEWALKS**

Concrete curbs and sidewalks shall be as specified herein and per the City of Salinas Standard Plans. For new construction, the developer and engineer shall follow the guidelines as established in Section 3.2 "LID Designs for Paved Surfaces" of the latest Edition of "The City of Salinas Storm Water Development Standards For New Development and Significant Redevelopment Projects".

**73-1.01 Description** - This work shall consist of constructing curbs, gutters, sidewalks, island paving, and driveways of the form and dimensions shown on the Plans, on the City of Salinas Standard Plans, or as specified in these Specifications, and the Special Provisions. They shall be constructed of Class 3 concrete conforming to the Provisions in Section 90 with a maximum slump of four inches (4") as determined by the slump cone method, and reinforcement shall conform to the Provisions of Section 52, "Reinforcement".

**73-1.02 Subgrade Preparation** - The subgrade shall be constructed true to grade and cross section, as shown on the Plans or as directed by the City Engineer. It shall be watered and thoroughly compacted by mechanical means before placing the concrete. All soft and spongy materials shall be removed to a depth of not less than one-half foot (0.5') below subgrade elevation for curbs, island paving, and driveways and one-quarter foot (0.25') below for sidewalks, and the resulting space filled with earth, sand, or gravel of a quality that when moistened and compacted shall form a stable foundation. The subgrade for all driveways shall be compacted to a relative compaction of not less than ninety percent (90%).

Base material as called for in the City of Salinas Standard Plans shall be placed, compacted, wetted, and tested for grade and cross section by means of a template supported on the side forms. The base material and forms shall be wet immediately in advance of placing concrete.

**73-1.03 Existing Curbs, Gutters, Driveways, and Sidewalks** - Where the Plans provide for the reconstruction of a portion of an existing curb, gutter, driveway, or sidewalk, the existing section shall be cut to a minimum depth of one and one-half inches (1-1/2") with an abrasive type saw at the first scoring line at or beyond the planned joint or as designated by the City Engineer. The entire section to be reconstructed shall be removed. Remnants of asphalt concrete ramps on the remaining walkways shall also be removed from the concrete. The new curb, gutter, driveway, or sidewalk shall join the old work at this line. No sawing is necessary along an existing construction joint where an area designated for removal abuts such a joint.

**73-1.04 Forms** - Forms shall be true and shall have a smooth straight upper edge.

Timber forms shall be surfaced on the side placed next to the concrete and shall have a true surfaced upper edge and shall not be less than one and one-half inches (1-1/2") thick after being surfaced, except on curves.

All forms shall be thoroughly cleaned and coated with form oil to prevent the concrete from adhering to them.

Nominal dimension back forms may be used for Type "B", and Type "C", and roll type curb. All face of gutter forms shall be full dimension.

Forms shall be carefully set to alignment and grade and shall conform to the required dimensions. Forms shall be held rigidly in place by iron or wooden stakes placed at intervals not to exceed four feet (4'). Clamps, spreaders, and braces shall be used where required to insure rigidity in the forms.

Benders or thin plank forms may be used on curves, grade changes, or for curb returns. Back forms for curb returns may be made of one-half inch (1/2") thick benders created together for the full depth of the curb.

The form on the front of curbs shall not be removed while the concrete is sufficiently plastic to slump. Side forms for sidewalks, island paving, and curbs, except for the face, shall not be removed in less than twelve hours (12 hrs) after the finishing has been completed.

**73-1.05 Curb Construction** - In constructing curbs, entrances shall be provided for driveways as shown on the Plans or designated by the City Engineer.

Concrete curbs to be constructed over an existing pavement shall be anchored to the pavement

by means of steel dowels firmly grouted with 1:1 Portland cement and sand grout in holes drilled in the pavement except as provided in Section 73-1.06, "*Extruded Curb Construction*". Dowels shall conform to the provisions for bar reinforcing steel in Section 52, "*Reinforcement*," and shall be spaced and sized as shown on the Plans or per City of Salinas Standard Plans. Approved anchor bolts may be used in lieu of dowels at the option of the Contractor.

Expansion joints three-eighths inch (3/8") wide shall be constructed in curbs at twenty-four feet (24') intervals except for extruded curb, which shall be at sixty feet (60') intervals and at the ends of curb returns, except that expansion joints shall not be constructed within twenty-four feet (24') of an island nose. Expansion joints shall be filled with premolded joint filler conforming to the Provisions of Section 51, "*Concrete Structures*". Expansion joint filler shall be shaped to the cross section of the curb. Weakened plane joints (deep score) shall be constructed at twelve feet (12') intervals.

Concrete shall be placed and compacted in forms without segregation.

Immediately after removing the front curb forms, the face of the curb shall be troweled smooth to a depth of not less than seventeen hundredths foot (0.17') below the flow line or to the flow line of integral curb and gutter, and then finished with a steel trowel. The top shall be finished and the front and back edges rounded as shown on the Plans or per City of Salinas Standard Plans. Concrete placed next to expansion joints shall be finished with an edge tool.

The face of the finished curb shall be true, straight, and the top surface of curbs shall be of uniform width, free from humps, sags, or other irregularities. When a straight edge ten feet (10') long is laid on top of face of the curb or on the surface of gutters, the surface shall not vary more than two hundredths foot (0.02') from the edge of the straight edge, except at grade changes or curves. The top of finished curb shall not vary more than two hundredths foot (0.02') above or below the grade established by the City Engineer. The Contractor at his/her expense shall furnish the straight edge to the City Engineer to check the surfaces and the straight edge shall be returned upon completion of the check.

Exposed surfaces of curbs shall be cured by the pigmented curing compound resin type method as provided in Section 90-7.01B, except that the curbs may be sprinkled with water as soon after finishing as possible without pitting the surface and shall in that case be kept moist in this manner for a period of seven (7) calendar days between the hours of sunrise and sunset.

Curbs and gutters shall be water tested for flow line characteristics.

The Contractor shall at his/her expense clean all discolored concrete and repair or remove graffiti on the concrete. Abrasive blast cleaning may clean the concrete.

Unless otherwise approved by the City Engineer, repairs shall be made by removing and replacing the entire unit between scoring lines or joints.

**73-1.051 Extruded or Slip-Formed Curb Construction** - Any curb, except on structures, may be placed by using an extrusion machine or slip-form paver provided the finished curb is true to line and grade and the concrete is dense and of the required surface texture.

The concrete shall comply with the requirements in Section 73-1.01, "*Description*", except that the aggregate grading limits proposed by the Contractor shall be further restricted if

necessary to produce concrete that has well defined web marks of water on the surface and is free from surface pits larger than three-sixteenths inch (3/16") in diameter.

The concrete shall be of such consistency that it shall maintain the shape of the curb section without support. It shall contain the maximum amount of water that shall permit this result.

At the Contractor's option, concrete curbs to be constructed over an existing pavement shall be anchored to existing pavement either by placing steel dowels and reinforcing steel, as provided in Section 73-1.05, "*Curb Construction*", or by using an adhesive. If an adhesive is used, in advance of extruding or slip forming the curbs on the existing pavement, the surface of the pavement shall be thoroughly cleaned including removing any existing traffic stripping and the adhesive shall be applied. The pavement shall be cleaned either by wire brushing or by blast cleaning, except that blast cleaning shall be used only if directed by the City Engineer. The cleaned surface shall be free from dust, loose material, or oil.

The adhesive shall consist of two (2) components that shall be mixed together at the site of the work and shall conform to the requirements in Section 95-2.03, "*Epoxy Resin Adhesive for Bonding New Concrete to Old Concrete*".

The grade for the top of extruded curb shall be indicated by an offset guideline set by the Contractor from survey marks established by the City Engineer. The forming tube portion of the extrusion machine shall be readily adjustable vertically during the forward motion of the machine to provide, when necessary, a variable height of curb confirming to the predetermined curb grade. A grade line gage or pointer shall be attached to the machine in such manner that a continual comparison can be made between the curb being placed and the established curb grade as indicated by the offset guideline.

In lieu of the above method for maintaining the curb grade, the extrusion machine may be operated on rails or forms set at uniform depth below the predetermined finished top of the curb grade.

Concrete shall be fed into the extrusion machine at a uniform rate. The machine shall be operated under sufficient uniform restraint to forward motion to produce a well compacted mass of concrete free from surface pits larger than three-sixteenths inch (3/16") in diameter and requiring no further finishing, other than light brushing with a brush filled with water only. Finishing with a brush application of grout shall not be permitted.

Equipment for slip-forming curbs shall be controlled automatically for alignment, grade, and cross slope by sensing from preset string lines, or by string line control of alignment and grade and automatic cross-slope control. Equipment for slip-forming curbs shall have traveling forms of dimension, shape, and strength necessary to produce the required cross section of the curb. The equipment shall spread, consolidate, and finish the concrete so that a minimum of handwork shall be required to produce dense, homogeneous concrete true to grade and cross section. Concrete shall be consolidated effectively by internal vibrators, or by other means approved by the City Engineer.

Expansion joints shall be constructed as specified in Section 73-1.05, "*Curb Construction*", or shall be constructed by sawing through the curb section to its full depth. The width of the cut shall be such as to admit the joint filler with a snug fit. Premolded joint filler for sawed joints shall be inserted and mortared in place.



If sawing is performed after the concrete has hardened, the adjacent portions of the curb shall be supported firmly with close fitting shields. The operations of sawing and inserting the joint filler shall be completed before curing the concrete.

If sawing is performed before the concrete has hardened, the joint filler shall be mortared in place with heavy trowel pressure. After sawing is performed, all exposed portions of the curb in the vicinity of the joint shall be covered with another application of curing compound.

At the conclusion of the curing period, the filler in each sawed joint shall be checked for tightness of fit. The loose filler in any sawed joint shall again be mortared in place and cured.

**73-1.052 Drainage Outlets Through Curb** - The Contractor shall be required to provide suitable outlets through new curb for all existing building drains along the line of the work. Where sidewalk shall be higher than adjacent property, the Contractor shall provide curb drains per City Standard Plan 19.

**73-1.06 Sidewalk, Gutter Depression, Island Paving, ADA Pedestrian Access Ramp, and Driveway Construction** - Fresh concrete shall be struck off and compacted until a layer of mortar has been brought to the surface. The surface shall be finished to grade and cross-sections with a float, troweled smooth and finished with a broom. Brooming shall be transverse to the line of traffic and if water is necessary, it shall be applied to the surface immediately in advance of brooming.

The surface of sidewalks shall be scored at intervals not more than four feet (4') and shall correspond with the weakened plane and expansion joints of the curbs, unless otherwise directed by the City Engineer. Sidewalk with width greater than five and one-half feet (5.5'), it shall have a centered score line and parallel to the curb. ADA pedestrian access ramps shall be scored in accordance per the City Standard Plans. A scoring tool shall be used which shall leave the edges rounded.

On straight work, the scoring lines shall be perpendicular to the line of the work; at curves, the scoring lines shall be radial to the curb; when longitudinal scoring lines are required, they shall be parallel to, or concentric with the line of the work. When sidewalk is constructed adjacent to the curb, dowels in accordance with the Standard Plans shall be installed.

Expansion joints three-eighths inch (3/8") wide shall be constructed at all returns and opposite expansion joints in a adjacent curb. Where curb is not adjacent, expansion joints shall be constructed at intervals of twenty-four feet (24'). Expansion joints shall be filled with premolded joint filler conforming to the Provisions of Section 51-1.12C of these Specifications. Expansion joint filler shall be shaped to fit the concrete that is being placed, with the edge placed one eighth inch (1/8") below the top of the finished concrete surface. Concrete placed next to an expansion joint shall be finished with an edge tool. Weakened plane joints shall be constructed at twelve feet (12') intervals.

The surface shall not vary more than two-hundredth foot (0.02') from a ten foot (10') straightedge, except at grade changes, and the finished surface shall be free from blemishes. The Contractor at his/her expense shall furnish the straight edge to the City Engineer to check the surfaces and the straight edge shall be returned upon completion of the check.

Concrete sidewalks, island paving, driveways, and gutters, shall be cured as provided in Section 90 of these Specifications. If the pigmented curing compound method is used, the manual

operation of an unshielded spray nozzle shall be permitted.

**73-1.07 Measurement** - Quantities of curbs, sidewalk, gutter depression, island paving, gutters, and driveways shall be measured in linear foot or square foot, as indicated in the Proposal.

All base material, reinforcing steel, expansion joint material, shall be considered as included in the unit price paid for other items, except as noted below.

**73-1.08 Payment** - Quantities of curbs, gutters, sidewalks, gutter depressions, island paving, and driveways shall be paid for at the Contract price per linear foot or square foot as indicated in the Proposal, which prices shall include full compensation for any necessary excavation, subgrade preparation, and backfill, for furnishing and applying water, curb dowels, reinforcing steel, base material, and expansion material, and no separate payment shall be made therefore, unless otherwise specified in the Special Provisions or shown on the Plans.

Payment for curb, or curb and gutter, constructed as part of a catch basin, as shown on the Standard Plans, shall be included in the Contract price for each catch basin and no other compensation shall be allowed.

Payment for depressed curbs at driveways or ADA pedestrian access ramps shall be at the Contract unit price for type of curbs specified and no additional compensation shall be allowed therefore.

Payment for construction of Type A, C, and D ADA pedestrian access ramps shall be calculated by multiplying the square footage from grade break to grade break on sidewalk with the unit cost, and no additional compensation shall be allowed therefore. Payment for construction of Type B ADA pedestrian access ramp shall be calculated by multiplying the square footage from grove to grove as shown on the Standard Plan with the unit cost, and no additional compensation shall be allowed therefore.

The above prices and payments shall include full compensation for furnishing all labor, materials, tools, equipment, and incidentals, and for doing all the work involved in constructing curbs gutters, sidewalks, island paving and driveways, complete-in-place, as shown on the Plans, as specified in these Specifications, the Special Provisions, and as directed by the City Engineer.

## **SECTION 74**

### **PUMPING PLANT EQUIPMENT**

Pumping plant equipment shall be as specified in Section 74 of the State Standard Specifications.

## **SECTION 75**

### **MISCELLANEOUS METAL**

Miscellaneous metal shall be as specified in Section 75 of the State Standard Specifications.

## **SECTION 76 THROUGH 79**

**(BLANKS)**

## SECTION 80

### FENCES

Fences shall be as specified in Section 80 of the State Standard Specifications.

## SECTION 81

### MONUMENTS

Monuments shall be as specified in the State Standard Specifications, except as herein modified.

**81-1.01 Description** - This work shall consist of furnishing and installing Portland cement concrete survey monuments at the locations shown on the Plans or as directed by the City Engineer, as specified in the Specifications, and the Special Provisions.

Concrete shall be Class 3 Concrete in accordance with Section 90 of the Standard Specifications using three-quarter inch (3/4") maximum size aggregate.

Bronze plates shall be punched with the precise monument location point at a minimum depth of three-thirty-second inch (3/32"), shall contain the registration number of the licensed surveyor or registered civil engineer that set the point and shall be as shown on the Standard Plans.

Elevations and State Plane Coordinates for set points shall be provided to the City of Salinas on electronic media by a licensed surveyor or registered civil engineer certified to do land surveying for inclusion in the City's Benchmark Records.

The upper portion of the survey monuments shall consist of a cast steel valve box top, constructed and marked as shown on the Standard Plans.

**81-1.03 Construction** - The concrete portion of the monuments shall be cast-in-place using the adjacent earth for exterior forms. The holes forming such monuments shall be neat and true according to the Standard Plan.

The bronze marker shall be placed in survey monuments before the concrete block has acquired its initial set, and shall be firmly bedded in the concrete. When the plate is inserted, the reference point shall fall within a one inch (1") diameter circle in the center of the plate, and the plate shall fall within a three inch (3") diameter circle in the center of the concrete block.

**81-1.04 Installation** - Survey monument shall be installed as shown on the Standard Plan. The top of the steel valve box cap shall be flush with the finished pavement grade.

**81-1.05 Measurement** - The quantity of monuments furnished and installed shall be paid for as units determined from actual count.

**81-1.06 Payment** - The unit price paid for survey monuments shall include full compensation for furnishing all labor, materials including bronze marker, tools, equipment and incidentals, and for doing all the work involved in furnishing and installing the monuments complete-in-place, including necessary excavation and backfill as shown on the Plans and specified in these Specifications, the Special Provisions, and as directed and located by the City Engineer.

**SECTION 82**  
**MARKERS AND DELINEATORS**

Markers shall be as specified in Section 82 of the State Standard Specifications.

**SECTION 83**  
**RAILING AND BARRIERS**

Guard railings and barriers shall be as specified in Section 83 of the State Standard Specifications.

**SECTION 84**  
**TRAFFIC STRIPES AND PAVEMENT MARKINGS**

Traffic stripes and pavement markings shall be as specified in Section 84-1 and 84-2 of the State Standard Specification and City of Salinas Standard Plans 37A, 37B, 38, 39 40, 41, 42, 43, and 44 except as modified herein. Delete Section 84-3 of the State Standard Specifications.

**84-1.02 Control of Alignment and Layout** - Add the following paragraphs to this subsection:

Cat tracking is required before permanent striping, markings and markers are placed and shall be approved by the City Engineer before final striping, markings, and markers are constructed. All additional work necessary to establish satisfactory lines for striping shall be performed by the Contractor at his/her expense, including correction of irregularities in the alignment of cat tracks or dribble lines and removal of the cat tracks upon completion of the work.

For traffic safety, the Contractor shall submit a Plan, for approval, that shall provide for temporary safety striping after removal of existing pavement striping, markings, and markers before resurfacing is completed. The Plan shall include temporary safety striping after resurfacing is completed until construction of cat tracking for final striping, markings, and markers. The Contractor, at his/her expense, shall maintain the approved Plan, until final striping, markings, and markers are constructed.

Cat tracking shall consist of placing spots of paint not more than two inches (2") in width and not more than five feet (5') apart. Paint for cat tracks shall be the same color as the one used for the new thermoplastic traffic striping for which it is placed. The paint use for cat tracking shall be fast dry solvent borne yellow, white, and black, and shall conform to State Specification No. 8010-51K-04. Temporary adhesive type cat tracking may be used upon approval by the City Engineer but shall be removed by the Contractor at his/her expense prior to placing permanent striping, legends or markings.

**84-1.03 Tolerances and Appearance** - Add the following to the first paragraph of the State Standard Specification: Traffic striping, legends, or pavement markings shall be installed on the pavement in a professional manner at the locations specified on the Plans or as directed by the City Engineer.

**84-2.02 Materials** - Delete this section in the State Standard Specifications and insert the following:

The City of Salinas uses alkyd thermoplastic material and glass beads in the application and maintenance of pavement striping, legends or markings. The white, yellow, and black thermoplastic material shall be “lead free”.

Glass Beads (Pre-Mix) shall be uncoated and conform to AASHTO M247-81 Type 1.

The Thermoplastic material shall be homogeneously composed of pigment, filler, resins, and glass reflecting spheres. The vendor shall have the option of formulating the material according to his/her own Specifications. However, the solid resin shall be “maleic-modified glycerol ester resin” (alkyd binder). The physical and chemical properties as specified below shall apply regardless of the type of formulation.

The thermoplastic material shall not deteriorate on contact with sodium chloride, calcium chloride or other de-icing chemicals, or because of oil content of paving materials, or oil droppings.

The thermoplastic mixture specific gravity of the white and yellow thermoplastic traffic line material shall not exceed 2.20 and the composition shall have pigment, beads and filler uniformly dispersed in the resin. The composition shall be free from all skins, dirt, and foreign objects and shall comply with the following requirements:

**COMPOSITION (percent by mass [weight])**

<u>Component</u>	<u>White</u>	<u>Yellow</u>	<u>Black</u>
Binder See Note (b)	18.0 min.	18.0 min.	18.0 min.
Glass Beads	30-40	30-40	0.0 max.
Titanium Dioxide	10.0 min.	--	0.0 max.
Calcium Carbonate & Inert Fillers	42.0 max.	50.0 max.	52.0 max.
Yellow and Black Pigments	--	See note (a)	See note (a)

Note (a): Amount of yellow and black pigment, calcium carbonate and inert filler shall be at the option of the manufacturer, providing all other requirements of these Specifications are met.

Note (b): Alkyd binder shall consist of a mixture of synthetic resin, at least one (1) of which is solid at room temperature, and high boiling point plasticizers. At least one-third ( 1/3) of the binder composition shall be solid maleic-modified glycerol ester resin and shall be no less than eight percent (8%) by weight of the entire material formulation. The binder shall not contain petroleum based hydrocarbon resins.

**84-2.021 Characteristics** - The thermoplastic mixture shall contain the following physical characteristics:

1. *Color* - The thermoplastic material after heating for four hours (4hrs) plus/minus five minutes ( $\pm 5$  min.) at four hundred and twenty-five  $\pm$  three degrees Fahrenheit ( $425 \pm 3^\circ\text{F}$ ) under agitation shall meet the following:

White:	Daylight reflectance at forty-five to zero degrees ( $45^\circ$ to $0^\circ$ ) – seventy-five percent (75%) minimum
Yellow:	Daylight reflectance at forty-five to zero degrees ( $45^\circ$ to $0^\circ$ ) – forty-five percent (45%) minimum

For highway use, the yellow color shall reasonably match color chip No. 13538 of Federal Standard Number 595. [ Test performed at seventy-seven degrees Fahrenheit ( $77^\circ\text{F}$ )].

2. *Set Time* - When applied at a temperature range of four hundred twelve and one-half  $\pm$  twelve degrees ( $412.5 \pm 12^\circ\text{F}$ ) and thickness of six hundredth inch ( $0.06''$ ) to one hundred and twenty-five hundredth inch ( $0.125''$ ) the material shall set to bear traffic in not more than two (2) minutes when the air temperature is fifty  $\pm$  three degrees Fahrenheit ( $50 \pm 3^\circ\text{F}$ ) and not more than ten minutes (10 min.) when the air temperature is ninety  $\pm$  three degrees Fahrenheit ( $90 \pm 3^\circ\text{F}$ ) and not more than ten minutes (10) when the air temperature is ninety  $\pm$  three degrees Fahrenheit ( $90 \pm 3^\circ\text{F}$ ).
3. *Bond Strength* - After heating the thermoplastic material for four hours (4 hrs) plus/minus five minutes ( $\pm 5$  min.) at four hundred and twenty-five degrees ( $425^\circ\text{F}$ ), the bond strength to Portland cement concrete shall exceed one hundred psi (180 psi.).
4. *Cracking Resistance at Low Temperature* - After heating the thermoplastic material for four hours (4 hrs) plus/minus five minutes ( $\pm 5$  min.) at four hundred and twenty-five  $\pm$  three degrees Fahrenheit ( $425 \pm 3^\circ\text{F}$ ), applying to concrete blocks, and cooling fifteen  $\pm$  three degrees Fahrenheit ( $15 \pm 3^\circ\text{F}$ ), the material shall show no cracks.
5. *Impact Resistance* - After heating the thermoplastic material for four hours (4 hrs) plus/minus five minutes ( $\pm 5$  min.) at four hundred and twenty-five  $\pm$  three degrees Fahrenheit ( $425 \pm 3^\circ\text{F}$ ) and forming test specimens, the impact resistance shall be minimum of ten inch-pounds (10 in.-lbs.).
6. *Softening Point* - After heating the thermoplastic material for four hours (4 hrs) plus/minus five minutes ( $\pm 5$  min.) at four hundred and twenty-five  $\pm$  three degrees Fahrenheit ( $425 \pm 3^\circ\text{F}$ ) and testing the accordance with ASTM D-36, the materials shall have a softening point of two hundred and fifteen  $\pm$  fifteen degrees Fahrenheit ( $215 \pm 15^\circ\text{F}$ ).
7. *Flowability* - After heating the thermoplastic material for four hours (4 hrs) plus/minus five minutes ( $\pm 5$  min.) at four hundred and twenty-five  $\pm$  three degrees Fahrenheit ( $425 \pm 3^\circ\text{F}$ ) and testing for flowability, the white thermoplastic material shall have a maximum residue of eighteen percent (18%) and the yellow thermoplastic material shall have a maximum residue of twenty-one percent (21%).

8. *Yellowness, Extended Heating* - After heating and stirring the thermoplastic material for eight and one-half hours (8-1/2 hrs) at four hundred and twenty-five  $\pm$  three degrees Fahrenheit ( $425 \pm 3^{\circ}\text{F}$ ) the thermoplastic materials shall not exceed a yellowness index of 0.15.
9. *Flowability, Extended Heating* - After heating and stirring the thermoplastic material for eight and one-half hours (8-1/2 hrs) at four hundred and twenty-five  $\pm$  three degrees Fahrenheit ( $425 \pm 3^{\circ}\text{F}$ ) and tested for flowability, the thermoplastic material shall have a minimum residue of twenty-eight percent (28%).
10. *Storage Life* - Thermoplastic material furnished in granular and block form shall meet the above requirements for a minimum period of one (1) year. The thermoplastic must melt uniformly with no evidence of skins or unmelted particles during this one (1) year period. The Contractor at his/her expense shall replace material not meeting the above requirements.

**84-2.022 Packaging** - The thermoplastic materials shall be packaged in suitable containers to which it shall not adhere during shipment and storage. Each container shall designate the color, alkyl binder, extrude, user information, manufacturer's name and address, batch number, and date of manufacturer. Each batch manufactured shall have its own separate number. The label shall warn the user that the material shall be heated in the range of 400-440 $^{\circ}\text{F}$ . The container shall be so constructed as to allow easy removal of the material from the lining.

**84-2.03 Testing** - The Contractor's attention is directed to Section 6-3.02, "Testing," of these Standard Specifications. The material shall be tested in accordance with AASHTO T250 and M-249 or with the appropriate method in Federal Test Method Standard No. 141 or ASTM designation.

The material supplier shall secure the services of a certified independent testing laboratory to obtain samples of material during production and test the material for compliance with the Specifications. The City Engineer shall determine the frequency of testing depending on the results of previous compliance tests.

When requested by the City Engineer, the independent testing laboratory shall sample one (1) or all of the production batches to be supplied to the City. The testing laboratory shall mark each box in the batch(s) tested for subsequent retesting by the City, and supply the test results to the City Engineer.

The costs for all testing by the independent testing laboratory shall be borne by the Contractor.

**84-2.04 Application** - Delete this Section in the State Standards in its entirety and insert the following:

Existing surfaces that are to receive the thermoplastic material shall be mechanically wire brushed to remove all dirt and contaminants. Surfaces of new Portland cement concrete pavement to receive the thermoplastic material shall be mechanically wire brushed or abrasive blast cleaned to remove all laitance and curing compound.

A primer, of the type recommended by the manufacturer of the thermoplastic material, shall be applied to all asphaltic surfaces over six months (6 months) old and to all Portland cement concrete surfaces. The primer shall be applied immediately in advance of, but concurrent with, the application of the thermoplastic material. The primer shall be applied at the application rate recommended by the manufacturer and shall not be thinned.

The Contractor shall meet all requirements and tests that may be imposed by the Monterey Bay Unified Air Pollution Control District and the California Air Resources Board for control over thermoplastic fumes or other emissions into the air, in accordance with the schedules established by those authorities.

The thermoplastic material shall readily apply to the pavement at temperatures of four hundred to four hundred and forty degrees Fahrenheit (400-440°F) from approved equipment to produce an extruded line that shall be continuous and uniform in shape having clear and sharp dimensions one hundred and twenty-five thousandths inch (0.125") for screen extrusion or nine hundredths inch (0.09") for ribbon extrusion.

The material shall not exude fumes, which are toxic, obnoxious or injurious to persons or property when it is heated during applications. The manufacturer shall provide product safety data sheets for their product.

The application of additional glass beads by drop-on or pressure spray methods shall be at an approximate uniform rate of ten pounds (10 lbs) of glass spheres every one hundred square feet (100 feet<sup>2</sup>) of line. The glass spheres shall conform to AASHTO M247-81 (1986) Type 1 except that the beads shall be moisture resistant coated as meet the requirement of 4.4.2 (AASHTO M247-41) and a maximum of five percent (5%) shall pass the number eighty (80) screen; glass spheres shall have a minimum of seventy percent (70%) true spheres on each sieve.

Application of the thermoplastic and beads shall be at the following rates and in conformance with the following requirements:

1. All pavement striping, legends and/or markings shall comply with the Standard Specifications and Special Provisions. The Contractor shall furnish templates, stencils that will match the stencil set currently used by City of Salinas, or other devices approved by the City Engineer to provide straight uniform lines, to provide uniform and neat letters/symbols, pavement messages contained in the bid document and additions as may be required by the City Engineer. Contractor shall furnish to the City all stencils that were used upon completion of the project.
2. All letters, symbols, and pavement messages are to be installed to current Federal Standards, unless otherwise specified or directed by the City Engineer.
3. Immediately following the application of the thermoplastic material, glass beads shall be applied to the surface of the molten material at a minimum rate of eight pounds (8 lbs) per one hundred square feet (100 ft<sup>2</sup>).
4. The thermoplastic may be applied by either ribbon gun or shoe methods providing the specified thickness, in a single uniform layer, is obtained. The road surfaces shall be completely coated and the voids in the road surface filled. For refurbishment of existing thermoplastic striping, the material shall be applied by the spray method.



The widths of markings shall conform to the limits specified on the Plans, and these Special Provisions. It shall have clear and sharp dimensions without running or deformation of the edges.

5. Description of Surface	Thickness - mil
New thermoplastic traffic striping installed on new pavement or over existing painted striping	90-100
Refurbishment of existing thermoplastic striping	30-50
Thermoplastic Cross-Walks and Legends	120-150

6. The Contractor shall take all reasonable precautions to protect the thermoplastic material during drying time and shall be required to remove and correct all objectionable tracking and deformation of the thermoplastic markings.

**84-2.041 Traffic Control** - The Contractor's attention is directed to Section 7-1.08, "Public Convenience" and Section 7-1.09, "Public Safety" of the Standard Specifications. The Contractor shall strictly adhere to the use of traffic warning and control devices as set forth in Section 12 of the Standard Specifications. The Contractor shall furnish and install all necessary traffic control devices called for in Section 12 of these Standard Specifications. The Contractor shall furnish the following additional control devices:

1. Rotating amber lights of a type specified by the State of California as approved lights and devices shall be prominently mounted on each piece of equipment and shall be in use at all times when the equipment is at the job site as prescribed in Sections 25256 and 25268 of the California Vehicle Code and Title 13 of the California Administrative Code.
2. A follow vehicle with a Type II sequential arrow board shall travel behind slow moving striping equipment complete with crash cushions.

The City Engineer may provide specific instructions in the use and placement of traffic control devices in any instance not covered in Section 7 and 12 of these Standard Specifications, or under subsections A and B above.

The Contractor shall notify the City Engineer forty hours (48 hrs) in advance of the actual work date to request the posting of signs, if required for performance of work per the Special Provisions.

**84-2.042 Application Equipment** - The striping Contractor shall own or have under Contractor direct control a minimum pre-melter capacity of eight thousand pounds (8,000 lbs), two (2) hand liners, a full set of work message stencils, and one (1) seven hundred and fifty pound (750 lb) capacity self propelled long line striper.

The striping machine shall be maneuverable to the extent that straight lines can be followed and normal curves can be made in true arcs.

The application equipment used for this Contract works shall be inspected by the City Engineer prior to award of Contract and shall conform to the following minimum requirements:

1. The applicators shall have a bead dispenser capable of uniformly applying beads on the thermoplastic material immediately after its application. Since bead deposition width, quantity and placement location are all operator adjustable the bead dispenser should be capable of consistent application regardless of operator application speed.
2. This applicator shall ensure that drop-on beads are firmly anchored in the thermoplastic for improved lifetime retro-reflectivity. It shall eliminate the blackout period of ten caused when applied drop-on beads improperly penetrate molten thermoplastic and are thereby easily dislodged by traffic.
3. The long line striper shall be equipped with an automatic on-off device to produce slip lines, with adjustment to match previous painting. It shall be capable of presetting accurate application thickness that is indicated by a gauge.
4. The long line striper shall be capable of installing edge lines within one foot (1') of a curb or berm.
5. The long line striper shall be capable of installing a double yellow centerline at the rate of four miles per hour (4 MPH).

**84-2.043 Curb Painting** - Painting of tops and faces of existing and new curbs and asphaltic concrete dike shall be as shown on the Plans or in the Special Provisions.

Paint for existing asphalt concrete dike shall be color white, reflective paint for application without primer to the asphalt concrete dike surface. The paint shall conform to State Specification No. 8010-51K-04 fast dry solvent borne white paint. Immediately after painting, apply Type II Reflective Glass Beads conforming to State Standard Specification No. 8010-71L-22, at a rate of six pounds (6 lbs) to eight pounds (8 lbs) of glass spheres per one gallon (1 gal) of traffic paint.

**84-2.044 Alignment** - On all work, such as a crosswalk, limit lines, and locations of work messages/arrows, Contractor shall install new markings such that it shall match all existing lines in such a manner as to present a uniform, pleasing appearance, and misalignment or disregard for previous markings shall not be permitted. Abrupt breaks in alignment between broken segments shall not be permitted. The City Engineer shall be the sole judge of the accuracy and acceptability of the alignment of the work.

**84-2.045 Changes in the Work** - In general the quantities indicated on the Proposal are estimates only and are subject to increases or decreases. The City reserves the right to modify by adding or deleting work on work orders, maps, or other instructions provided to the Contractor.

**84-2.046 Correction of Work** - The City Engineer shall be the sole judge as to the acceptability of the work and shall inspect the completed work, informing the Contractor of any faulty methods or unsatisfactory results. It shall be the Contractor's responsibility at his/her expense, to correct the work upon notification and provide proper interim traffic control in hazardous conditions.

**84-2.047 Warranty** - The Contractor's/Applicant's attention is directed to Section 2-1.12, "*Material Guaranty*," of these Standard Specifications. The Contractor/Applicant agrees to immediately repair and replace all defective material and workmanship discovered within one (1) year after acceptance by the City and to indemnify said City of Salinas against all loss and damage occasioned by any such defect, discovered within said year, even though the damage or loss may not be ascertained until after the expiration thereof. Provided, however, that if such failure of the Contractor to perform should not, by reasonable diligence, be discoverable or discovered within said one (1) year, then the obligation of the Contractor to repair and replace said defective material or workmanship shall continue until one (1) year after the actual discovery thereof.

A failure is defined as chipping, peeling, or separation of thermoplastic striping, legends, pavement marking, or parts thereof from the road surface. It shall be the Contractor's responsibility at his/her expense to restore the work upon notification and provide proper interim traffic control in hazardous conditions.

**84-2.048 Thermoplastic Removals** - The removal of existing striping as necessary to meet new striping shall be in accordance with Section 15-2.02B, "*Traffic Stripes and Pavement Markings*," of these Standard Specifications and the following requirements:

Thermoplastic removals, if necessary, shall be performed by the wet sandblasting technique, shot blasting, or grinding, meeting the latest requirements and restrictions by the State Pollution Control Agency.

Where sandblast cleaning is used for the removal of pavement markings or for removal of objectionable material, and such removal operation is being performed within ten feet (10') of a lane occupied by public traffic, the residue including dust shall be removed immediately after contact between sand and the surface being treated. Such removal shall be by a vacuum attachment operating concurrently with the blast cleaning operation, mechanical street sweeping devices, or by other methods approved by the City Engineer, as provided under "*Alternative Equipment*", of these Standard Specifications.

Alternate methods of removal require prior approval of the City Engineer. Obliteration of striping or markings with black paint shall be done only with prior approval of the City Engineer and shall be only a temporary measure requiring later removal as specified.

Existing yellow thermoplastic striping shall be tested for lead before removal. Removal of striping containing lead shall be done in accordance with City, State, and Federal requirements for disposal of lead containing materials

**84-2.06 Payment** - Add the following paragraphs to this Section:

Unless otherwise specified in the Special Provisions, curb painting as shown on the Plans and as specified in Section 84-2.043 shall be considered as included in the prices paid for the various Contract items of work and no separate payment shall be made therefore.

The Contract unit prices for painted traffic striping and pavement markings shall also include full compensation for cat tracking, traffic control, and furnishing paint and glass beads.

**SECTION 85**  
**PAVEMENT MARKERS**

Pavement markers shall be as specified in Section 85 of the State Standard Specifications, except as herein modified, and Standard Plan's No. 37A, 37B, and 38.

**85-1.06 Placement** - Add the following paragraphs to this section:

Unless otherwise specified, existing pavement markers shall be removed in accordance with Section 15 - 2.02C, "*Pavement Markers*", of the Standard specifications before pavement resurfacing or if they conflict with new pavement delineation.

Cat tracking for layout of marker alignment is required and shall be in accordance with Section 84-1.02, "*Control of Alignment*," of these Standard Specifications. Upon completion of pavement marker installation, the cat tracking shall be removed.

**85-1.09 Payment** - Add to the first paragraph of this Section the following:

Unless otherwise specified in the Special Provisions or on the Plans, the Contract unit prices paid for reflective or non-reflective pavement markers shall include full compensation for cat tracking with necessary removal after installation of the markers and, for removal of existing pavement markers with any necessary repair to the pavement due to the removal.

**SECTION 86**  
**SIGNALS AND LIGHTING**

Signals and lighting shall be as specified in Section 86 of the State Standard Specifications.

**SECTION 87**  
**(BLANK)**

**SECTION 88**  
**ENGINEERING FABRICS**

Engineering fabrics shall be as specified in Section 88 of the State Standard Specifications.

**SECTION 89**  
**LIGHTWEIGHT PORTLAND CEMENT CONCRETE**

Lightweight Portland cement concrete shall be as specified in Section 89 of the State Standard Specifications.

**SECTION 90**  
**PORTLAND CEMENT CONCRETE**

Portland cement concrete shall be as specified in Section 90 of the State Standard Specifications issued May, 2006, except as herein modified.

### **90-1.01 Description**

- Portland cement concrete shall be composed of Portland cement, fine aggregate, coarse aggregate, admixtures if used, and water, proportioned, and mixed, as specified in these specifications.
- Concrete for each portion of the work shall be of the Class, cement content in pounds per cubic yard, twenty-eight (28) calendar day compressive strength or minor concrete as shown on the Plans, or specified in these Specifications or the Special Provisions.
- Class 1 concrete shall contain not less than six hundred and seventy-five pounds (675 lbs) of cementitious material per cubic yard.
- Class 2 concrete shall contain not less than five hundred and ninety pounds (590 lbs) of cementitious material per cubic yard six (6 sack mix).
- Class 3 concrete shall contain not less than five hundred and five pounds (505 lbs) of cementitious material per cubic yard five sack mix (5 sack mix).
- Class 4 concrete shall contain not less than four hundred and twenty pounds (420 lbs) of cementitious material per cubic yard.
- Minor concrete shall contain not less than five hundred and fifty pounds (550 lbs) of cementitious material per cubic yard unless otherwise specified in these Specifications or the Special Provisions.

### **SECTION 91**

#### **PAINT**

Paint shall be as specified in Section 91 of the State Standard Specifications.

### **SECTION 92**

#### **ASPHALTS**

Asphalts shall be as specified in Section 92 of the State Standard Specifications.

### **SECTION 93**

#### **LIQUID ASPHALTS**

Liquid asphalt shall be as specified in Section 94 of the State Standard Specifications.

### **SECTION 94**

#### **ASPHALTIC EMULSIONS**

Asphaltic Emulsions shall be as specified in Section 94 of the State Standard Specifications.

**SECTION 95**

**EPOXY**

Epoxy shall be as specified in Section 95 of the State Standard Specifications.



# **CITY OF SALINAS**

## **DEVELOPMENT AND ENGINEERING SERVICES DEPARTMENT**

### **PART II**

#### **D E S I G N   S T A N D A R D S**

Part II Design Standards contain only units in the United States Standard Measures (USSM). The measurements expressed in this Part II are to be used for design calculations only. Final Plans and Specifications shall be in USSM as approved by the City Engineer.





# PART II

## DESIGN STANDARDS

### TABLE OF CONTENTS

#### GENERAL PROVISIONS

<i>Section No.</i>	<i>Title Description</i>	<i>Page No.</i>
<b>I.</b>	<b>Improvement Policy for Subdivisions and Unimproved Streets .....</b>	<b>Pg. 126-129</b>
	A. General .....	Pg. 126
	B. Roadway Paving.....	Pg. 126
	C. Curbs .....	Pg. 126
	D. Sidewalks .....	Pg. 126-127
	E. Driveways.....	Pg. 127
	F. Street Lighting.....	Pg. 127
	G. Monuments.....	Pg. 127-128
	H. Street Signs.....	Pg. 128
	I. Storm Drains .....	Pg. 128
	J. Sanitary Sewers.....	Pg. 128-129
	K. Fire Protection.....	Pg. 129
	L. Right-Of-Ways and Easements .....	Pg. 129
	M. Parking and Traffic Circulation.....	Pg. 129
<b>II.</b>	<b>Storm Drain Design .....</b>	<b>Pg. 130</b>
<b>III.</b>	<b>Sanitary Sewer Design.....</b>	<b>Pg. 130-131</b>
	A. Design.....	Pg. 130
	B. Depth of Sewers .....	Pg. 130-131
	C. Connections to Sewers .....	Pg. 131
<b>IV.</b>	<b>Development Plan Check List.....</b>	<b>Pg. 132-133</b>
	1. Site Plans .....	Pg. 132
	A. General Requirements.....	Pg. 132
	B. Legal/Mapping Requirements.....	Pg. 132
	2. Construction Plans.....	Pg. 132
	A. Concrete Work .....	Pg. 132
	B. Drainage/Grading Plan.....	Pg. 133
	C. Sanitary Sewer Plan .....	Pg. 133
<b>V.</b>	<b>City of Salinas - Subdivision Processing Checklist .....</b>	<b>Pg. 134-135</b>
	1. Initial Submittal.....	Pg. 134
	2. Subsequent Submittal.....	Pg. 135
	3. Final Submittal .....	Pg. 135

**TABLE OF APPENDICES**

**Appendix A - Grading Standards**

**Development Plans.....Pg. 136-159**  
A. General .....Pg. 136  
B. Standards to Control Excavations, Cuts, Fills, .....  
Clearing, Grading, Erosion, and Sediment .....Pg. 136-159

## **I. IMPROVEMENT POLICY FOR SUBDIVISIONS AND UNIMPROVED STREETS**

**A. GENERAL** --- It is the City's policy to require all developers and subdividers to construct the public improvements within and adjacent to their property to City Standards. Unless specified otherwise, such improvements shall have appearance characteristics compatible with those of the neighborhood in which they are installed.

All public improvements shall be designed and constructed according to these Design Standards, Standard Plans, and Specifications adopted by the City Council, of the City of Salinas, unless the City Engineer approves specific modifications to such standards.

All work shall be consistent with the requirements of the City of Salinas Grading Standards as well as meeting the latest "Storm Water Development Standards" for new development and significant redevelopment projects, and the City's NPDES Permit, which can be found on the City's webpage [www.ci.salinas.ca.us](http://www.ci.salinas.ca.us) or copies may be obtained at Development and Engineering.

Part II Design Standards contain only units in the United States Standard Measures (USSM). The measurements expressed in this Part II are to be used for design calculations only. Final Plans and Specifications shall be in USSM as approved by the City Engineer.

**B. ROADWAY PAVING** --- Design procedures for rigid and flexible roadway pavements shall be based on Caltrans Methodology in accordance with Section 7 of the California State Design Manual, Traffic Index per Section 31-804.5 (Subdivisions) of Salinas Municipal Code, City Standard Plan No. 3 and these following requirements.

Basement soil "R" value tests shall be required for roadway pavement designs by qualified laboratories in accordance with testing procedures of Caltrans. Soil samples for R-Value tests shall be of sufficient number and at appropriate intervals to reflect R-Values representative of the entire development. Pavement structural section designs shall be governed by the lowest of obtained R-Values, with a minimum section as identified on City Standard Plan No. 3. Private parking areas shall be paved in accordance with R-Value tests with minimum three inches (3") asphalt concrete over six inches (6") of Class II baserock. Asphalt sections shall be paved with a half inch (1/2") maximum aggregate sized final course, and three-quarter inch (3/4") maximum aggregate sized base course(s).

**C. CURBS** --- Unless permitted otherwise, concrete vertical curbs with integral gutters shall be constructed throughout the City. In blocks where streets have already been improved with roll-type curbs, policies adopted separately from this document shall apply.

**D. SIDEWALKS** --- Concrete sidewalks shall be constructed in all residential, industrial, and commercial developments, unless designated otherwise by separate agreement. Sidewalks in commercial areas shall extend from the curb to a line not more than one foot (1') from the property line, or with a six feet (6') wide (minimum) meandering sidewalk as approved by the City Engineer. Residential sidewalks shall be minimum four feet (4') in width and shall be located one foot (1') (maximum) from the property line, except where permitted per City Standard Plan No. 2 or approved by the City Engineer. When the property line is less than nine feet (9'), in which case, the sidewalk shall be increased to five and one-half feet (5.5') wide, and located adjacent to the curb, providing four feet (4') (minimum) clearance around obstructions.

Sidewalks fronting schools, churches, and similar locations within residential areas with high pedestrian traffic may be constructed to either residential or commercial standards. Unless otherwise approved by the City Engineer, five and one-half feet (5.5') sidewalks adjacent to the curb shall be installed in industrial areas.

ADA Pedestrian access ramps shall be constructed within sidewalk areas at curb returns and other locations per City requirements.

**E. DRIVEWAYS** --- Driveways shall be constructed only at locations where access from private property is required. The design of driveways shall be as detailed on City Standard Plan's No. 5 and 6, and in conformance with City Resolution 6350 N.C.S., which establishes driveway regulations.

Commercial type driveways with heavy-duty curbs shall be constructed for all commercial, industrial applications, and multiple residential developments of three (3) or more units. The concrete thickness of disabled access ramps and commercial driveways approaches shall be increased an additional two inches (2") (minimum) more than said Standard Plans in heavier truck traffic areas to withstand the heavier traffic loads.

**F. STREET LIGHTING** --- A street lighting system shall be required of new developments, with service design and connection coordinated with the Utility Company. Street lighting designs including fixture wattage, pole locations, and spacing, and conduit shall be subject to review and approval of the Development and Engineering Services Department.

All Electrical work, materials, equipment, and incidentals including conduit, wiring, connections, and testing shall be in full accordance with the latest editions of the following:

1. National Electrical Code.
2. C.A.C., Title 24, Part 3: Basic Electrical Regulations.
3. California Occupational Safety and Health Act (CAL/OSHA): Low Wattage Electrical Orders.
4. All applicable local laws, regulations, and/or ordinances.
5. CAL/OSHA: Construction Safety Orders.

Electroliers and appurtenances shall be in accordance with City Standard Plans unless otherwise approved by the City Engineer. These installations shall be City-owned upon completion of the development.

City standard street light poles shall be Type 15, and spacing for residential shall be two hundred feet (200') maximum. For collector streets, spacing shall be two hundred feet (200') maximum alternating and arterials one hundred fifty feet (150') maximum alternating. Street lighting wattage shall be: 100W HPS for Residential, 150W HPS for Industrial, and 200-250W HPS Arterial/Commercial. The street light service and conduit run shall be one and one-half inch (1-1/2") Schedule 40 P.V.C. (typical). Street lights shall be placed where pedestrians cross the street, and shall provide a silhouette of the pedestrian.

**G. MONUMENTS** --- Standard street monuments, stamped with the license number of an RCE certified to do land surveying or PLS of a State of California licensed land surveyor, shall be constructed on the centerlines of streets at the following locations:

1. All intersections of street centerlines.
2. All beginnings and ends of curves.

Lot corners and subdivision corners shall be as specified in the Subdivision Ordinance, but shall be at least a one-half inch (1/2") diameter steel bar or three-quarter inch (3/4") diameter iron pipe, eighteen inches (18") long, installed six inches (6") below finished grade, with brass tag or plastic plug-in. Brass tag shall be stamped with RCE or PLS number of RCE or LS performing the survey.

Section 8771 of the Land Surveyors Act requires that all existing monuments shall be referred and reestablished when disturbed by new construction.

**H. STREET SIGNS** --- Street name signs shall be constructed at each intersection. Roadways of four (4) or more travel lanes shall be furnished with a minimum of two (2) street name signs. Traffic signs, together with appropriate pavement markings, striping and/or raised pavement markers, shall be installed as directed by the City Engineer.

**I. STORM DRAINS** --- Storm drains shall be designed and constructed to serve the development including any areas which shall ultimately drain through the development with the cost of oversizing to be shared per current City policy. All intersections requiring drainage improvements shall be served with underground pipes and appropriate drainage facilities. "T" intersections with low traffic volumes may use cross-gutters on the minor leg of the "T", but only as deemed necessary by the City Engineer. Siphons are not acceptable. A discharge/design storm calculations submittal is required. The minimum pipe sizes shall be twelve inches (12") minimum for laterals with a slope of one percent (1%) or greater, and fifteen inches (15") minimum for mains with a slope of four-tenth of a percent (0.4%) or greater. Pipe Strength shall be Class 3, 4, 5 RCP. Catch basins shall have a desired minimum depth of three feet (3') and a desired maximum depth of six feet (6').

**J. SANITARY SEWERS** --- Sanitary sewer mains and laterals shall be constructed to serve each lot. Laterals shall lead directly to the sewer main in the street. Sewer laterals shall not pass through lots other than the one served. Joint use of laterals is not permitted, except as allowed by the City-adopted Plumbing Code.

Sanitary sewer mains and trunk lines shall be designed to accommodate the development including affected portions of sewage service areas as applicable, in accordance with the Salinas Master Sewer Plan. Sewer main oversizing costs to be shared per current City policy. Discharge/Cleaning Velocity shall be at two (2) fps minimum, with pipe size of six inches (6") minimum serving a maximum of ten (10) homes. Pipe strength shall be high strength VCP, PVC-SDR 26 or HDPE-DR 26. Sanitary sewer laterals shall be PVC SDR 21. All pipe shall include integral rubber-gasket bell and spigot joints. Couplings shall not be used. Pipe Slopes shall be:

(6" Min. S = 1%)

(8" Min. S = 0.4%; 0.5% desired)

(10" Min. S = 0.26%; 0.3% desired)

(12" and above Min. S = 0.2%)

Manholes shall specify Ram-Nek gasketed joints and a “Elastuff 120 Mastic” finish to protect against corrosion and seepage. Manholes installed within floodplain limits shall include a diaphragm inset at the rim to minimize infiltration.

**K. FIRE PROTECTION** --- If required by local fire protection regulations, the development shall include fire protection systems including all necessary fire hydrants, valves, mains, and appurtenances, together with fire access lanes and equipment turn-arounds as applicable. Materials, equipment, and installation shall conform to the requirements of local water companies, City, State, and Federal agencies.

**L. RIGHT-OF-WAYS AND EASEMENTS** --- As a condition for development, street right-of-ways and/or easements for publicly owned and maintained facilities shall be conveyed to the City in accordance with current policy.

All plats and detailed descriptions necessary for recording of such conveyances shall be prepared/submitted by the developer in accordance with current City policies and procedures. Said documents shall be signed by a land surveyor or professional Civil Engineer licensed to do said work.

**M. PARKING AND TRAFFIC CIRCULATION** --- Access roadways, on-site parking and interior vehicular circulation designs shall be in accordance with current City policies, and the Salinas Zoning Code requirements for parking facilities.

Entrances/driveways to developments shall be located and designed with appropriate signing, striping and markings, divider strips, signalization and other traffic control devices as necessary to minimize conflicts with or disruptions to through traffic.

Parking layouts shall, and aisle dimensions shall be in accordance with Section 37-205 of the Salinas Municipal Code. For high-turnover rate parking, recommended stall dimensions are minimum nine feet (9') in width and nineteen feet (19') in length as measured along the angle of parking.

All parking areas shall be graded and paved to drain and delineated by painted lines and/or raised markers; as approved by the City Engineer and Planning Manager. Individual stalls adjacent to buildings, pedestrian walks, or other similar structures shall be separated by raised concrete curbs, sidewalks, planters, or other type of barrier. Where parking spaces abut pedestrian or landscape planters, the walkways and planters shall be of adequate width to provide for three feet (3') vehicle overhang, where such improvements are used for wheel stops. A minimum four feet (4') clearance for pedestrian traffic shall always be provided. Planted areas adjacent to paved parking or roadway areas shall be separated by vertical type curbs (Type “B” or Type “C”).

Provisions for handicapped parking stalls, with applicable ADA pedestrian access ramps, shall be included in the parking design, in accordance with latest State Standards.

On-site vehicular roadways shall include provisions for emergency vehicle corridors and turn-arounds in accordance with Fire Department regulations. Such corridors shall be adequately marked and/or signed to prohibit unauthorized parking.

## II. STORM DRAIN DESIGN

**A. DESIGN** --- Refer to latest City of Salinas Storm Water Development Standards For New And R edevelopment P rojects. Copies ar e ava ilable at t he C ity of S alinas D evelopment and Engineering Services Department or visit the city's web site at [www.ci.salinas.ca.us](http://www.ci.salinas.ca.us).

## III. SANITARY SEWER DESIGN

**A. DESIGN** --- Sanitary sewers shall be designed to discharge the expected peak flow when pipe is running full. Grades shall be sufficient to provide a velocity of at least two feet (2') per second when running full, and one and seventy-five hundredth feet (1.75') per second, at average rate of flow. Maximum velocity shall be limited to eight feet (8') per second. Friction factor (n) shall be taken as thirteen-thousandth (0.013) for Vitrified Clay Pipe. Manning's Formula Nomograph or other method of solution which relates pipe diameter, slope, discharge, and velocity, may be used. Unless approved by the City Engineer, no sewer mains less than eight inch (8") diameter shall be used. Six inch (6") mains may be approved for lines with ultimate maximum of ten (10) single-family units or less, and having a one percent (1%) minimum slope.

Design and sizing of sewer mains and major laterals shall be based upon the anticipated sewage discharge in accordance with the following criteria. On the basis of an average flow of one hundred gallons (100 gal.) per capita per day, the average flow rates (cfs/acre) shall be based upon allowable land use *densities* (units per acre) and average occupancy figures (persons per unit), per data furnished by the Planning Division of Development and Engineering Services Department charts and the following:

Peak flows shall be in accordance with the following table:

<u>SERVICE POPULATION</u>	<u>RATIO OF PEAK TO AVERAGE FLOW</u>
1,000	2.5
3,000	2.1
10,000	1.8
35,000	1.6
100,000	1.5

Infiltration and storm water inflow shall be at five hundred gallons (500 gal.) per acre per day for new sewer mains.

Sewers shall be designed parallel and offset from street centerline as practicable. Spacing of manholes shall not exceed five hundred feet (500') on lines under twelve inches (12") in diameter. All grades for sewer pipe shall be given in feet/foot to four (4) decimal places and preferably shall be divisible by four (4). In manholes where outlet pipe has a greater diameter than the inlets, the crowns or the eight-tenth diameter (0.8 dia.) lines should be matched. Where grades permit, a two-tenth foot (0.20') drop should be allowed at ninety degree (90°) alignment change in manholes, to insure sufficient fall. Drop manholes shall be constructed where the inlet/outlet differential is two feet (2') or greater.

**B. DEPTH OF SEWERS** --- Sewer mains and laterals shall be deep enough to insure adequate drainage of lowest sanitary fitting connected thereto and to accommodate any future building



extensions in the area. Sewer lateral connections to mains in Public Street rights-of-way shall be a minimum five feet (5') depth to top of pipe at property line.

**C. CONNECTIONS TO SEWERS** --- All lateral connections to sewer mains shall be made by means of wye branches, saddles, or manholes, with connections in accordance with City Standard Plans No. 25, 29, and 32 in the upper half of the sewer main. Lateral connections shall be vitrified clay pipe (VCP) or PVC-SDR-21 pipe not less than four inch (4") diameter and shall be laid to a minimum grade of one percent (1%) between sewer main and property line. A lateral cleanout shall be installed at property line. Additional wye branches shall be installed in the sewer mains for future anticipated services.

No roof drains or storm water inlets shall be connected to sanitary sewers, nor shall sanitary sewers be connected to storm drains.

Upon completion of sewer main installations of six inch (6") and larger diameter pipe within public easements and right-of-way, all sections of pipe shall be checked with television equipment and air tested in accordance with current requirements of the Development and Engineering Services Department. PVC mains shall also be tested with a ninety-five percent (95%) mandrel to ensure pipe roundness requirements are met.

Subject to prior City Engineer approval, swimming pools may be drained into storm drains. However, backwash shall be discharged to the sanitary sewer system.

## IV. DEVELOPMENT PLAN CHECK LIST

### 1. SITE PLANS (TO INCLUDE THE FOLLOWING):

#### A. General Requirements:

- Location Maps (Major Streets and Site Shown)
- Scale of Plans and North Arrows
- Official Street Name(s) (Adjacent to Site)
- House Numbers Clearly Identified and Posted
- Property Lines and Right-of-Way Lines Shown Correctly
- Easements Shown Correctly
- Official Plan Lines Indicated
- Existing Facilities Shown

#### B. Legal/Mapping Requirements:

- Property Dedication Required (Deeds/Plats), (Cut Corner, Widening Strip)
- Parcel Map to Split Lot(s)
- Record of Survey/Lot Line Adjustment
- Final Map (Major Subdivision)
- Conformity with Tentative Map (Review by Planning Services)
- Non-Access Frontages/Reservation Strips
- Utility Easements Required/Existing
- Sewer/Drainage Easements Required/Existing
- Thirty-five feet (35') Minimum Street Frontage for SFR lots
- Lot Areas Clearly Identified
- Lot Closures Conform with Calc Sheets
- Environmental Impact Report (Requirements)
- Survey Monuments/Property Corners Shown

### 2. CONSTRUCTION PLANS (TO INCLUDE THE FOLLOWING):

#### A. Concrete Work:

- Sidewalks (Show location and size)
- Driveways (Show type and width), (Special transitions or slopes)
- Curb and Gutter (Type, limits, and design slope)
- Pedestrian Access Ramps (City and ADA Requirements Met)
- Cross Gutters/Alleys/Approaches
- Special Design Considerations

B. Drainage/Grading Plan:

- Master Plan Conformance
- Special Flood Hazard Zones Identified
- Discharge/design storm (Calculations Req'd.)
- Pipe Sizes [twelve inches (12") minimum Laterals, fifteen inches (15") minimum Mains]
- Pipe Strength (Cl. 3, 4, 5 RCP, HDPE ADS N-12)
- Pipe Grades [Minimum twelve inches (12") Laterals, s = one percent (1%) Minimum]  
[Minimum Main s = two tenths percent (0.2%); greater than twenty-four inch (24") pipe]
- Catch basins [Minimum Depth = three feet (3'); Maximum Depth = six feet (6')]  
Specify Bike Safe and Type A or better
- Surface runoff contours/flows
- Affect on Adjacent Properties
- Manholes (Type and Invert Information) (Specify Ram-Nek Joints and Thoro-seal Finish)
- Curb Drain (Per City Standards); not for SFR
- Conflict Structures
- Pump Stations

C. Sanitary Sewer Plan:

- Master Plan Conformance
- Discharge/Cleaning Velocity [two (2) fps minimum]
- Pipe Sizes [six inches (6") minimum up to ten (10) homes]  
(Remaining main sizes based on discharges)
- Pipe Strength (Hi Strength VCP or HDPE/PVC SDR 26;  
PVC SDR 21 laterals)
- Pipe Slopes [six inches (6") Minimum S = one percent (1%)]  
[Eight inches (8") Minimum S = four tenths percent (0.4%); five tenths percent (0.5%) desired]  
[Ten inches (10") Minimum S = twenty-six hundredths percent (0.26%); three tenths percent (0.3%) desired]  
[Twelve inches (12") Minimum and above S = two tenths percent (0.2%)]
- Manholes ( Type and Invert Information) ( Specify R am-Nek J oints and T horo-seal Finish)
- Pump Stations (Overflow, Maintenance Responsibility)

## V. CITY OF SALINAS - SUBDIVISION PROCESSING CHECKLIST

### *SUBDIVISION:*

DATE TENTATIVE MAP APPROVED:

DATE TENTATIVE MAP EXPIRES:

DATE INITIAL SUBMITTAL RECEIVED:

DATE FINAL SUBMITTAL RECEIVED:

SUBDIVISION AGREEMENT DATE:

### 1. INITIAL SUBMITTAL

Before the City accepts a map for an initial submittal check, it shall include all of the following items:

1. Two (2) copies of the Subdivision Map signed by the City Engineer or surveyor. (CD/s or DVD/s required at final submittal with mylar)
2. A current title report.
3. A full set of boundary, lot, and area calculations.
4. Complete documentation (all pertinent deeds and record maps).
5. Two (2) sets of signed blue line construction Plans including the Grading Plan, Street Improvement Plan, Storm Drain Plan, Sanitary Sewer Plan, Water/Fire Safety Improvement Plan, Traffic Signing and Striping Plan, and Landscape Plans. ( CD/s or DVD/s requested at final submittal).
6. Earthwork Calculations (Section or Quadrants).
7. Pavement Design Calculations-Conform to City Standard Plan No. 3.
8. Two (2) copies of a geotechnical report
9. Two (2) copies of any geological investigation, which includes the area encompassed by this subdivision.
10. Two (2) sets of hydrology calculations and hydrology map.
11. Two (2) sets of hydraulic calculations.
12. Two (2) copies of an Engineer's cost estimate for all construction encompassed on the Plans, based on City construction costs.
13. Map checking fee for the Subdivision.
14. Non-refundable deposit of fifty percent (50%) of the engineering and inspection fee for construction Plan checking.

## 2. SUBSEQUENT SUBMITTAL

The second and all subsequent submittals should include the following items:

1. Two (2) copies of the revised Subdivision Map.
2. All waiver letters required by Section 66436 of the Subdivision Map Act.
3. Two (2) copies of the revised improvement Plans.
4. Two (2) sets of revised hydrology and hydraulic calculations.
5. Two (2) sets of retaining wall design and calculations.
6. Written notarized permission from any property owner where grading or drainage is proposed on adjacent property not owned by the applicant.
7. Previous Map and Improvement Plan check prints.
8. Previous hydrology and hydraulic calculation check sets.

## 3. FINAL SUBMITTAL

The following items shall be in the City Engineer's Office at least two (2) weeks prior to the City Council meeting at which action is expected:

1. Original signed/sealed Subdivision Map on mylar or vellum. ( Provide information in Autocad DWG format on CD/s, or DVD/s).
2. CD/s, or DVD/s, and other items as listed on note # 1.
3. Original tracing of all Improvement Plan and Grading Plan, along with one (1) mylar copy and two (2) blue line prints.
4. Three (3) copies of the Improvement Contract.
5. Bond or other approved form of improvement security.
6. Monumentation Bond or letter of waiver from Subdividers, Engineer/Surveyor.
7. Tax Clearance certificate.
8. Letter from County Assessor.
9. Recording fee. Check to be made payable to Monterey County Recorder.
10. Preliminary Subdivision Guarantee (Final Subdivision Guarantee required by County Recorder at time of recordation.)
11. Engineering and Inspection fees.
12. Prior to acceptance of subdivision improvements, benchmark elevations and State Plane coordinates for set points shall be provided to the City on electronic media by licensed surveyor or civil engineer (licensed to practice surveying) for inclusion in the City's Benchmark Records

## APPENDIX – A

### DEVELOPMENT PLANS

**A. GENERAL** --- Project development Plans shall contain sufficient detailed drawings of required public improvements including streets, drainage, and sewer facilities, street lighting systems, utilities and related street improvements. Construction details shall include: typical roadway structural sections and curve data; locations, invert elevations, slopes, type and sizes of storm and sanitary sewer mains, laterals, manholes and appurtenant facilities; locations and depths of new and existing utilities; electrical and street lighting service points with light pole and conduit locations and conductor schedule; curbs and gutters, sidewalks, driveways, and other street improvements; and information of improvements/facilities located on adjacent properties showing they are not negatively impacted.

Plan and Profile drawings shall be furnished on standard twenty-four inch (24”) by thirty-six inch (36”) sheets with originals of legible, reproducible quality. Review Plans shall be prepared and submitted in accordance with the current policies. Where filing of Plans is required for public record, the completed, signed originals, or reproducible mylar sheets shall be furnished to the Development and Engineering Services Department.

Profiles of curbs and gutters, storm and sanitary sewers, and/or street centerlines (as applicable), shall be included on the Plans. Where practicable, such profiles shall be shown directly above or below the plan views and of equivalent scale.

Typical dimensioned design sections shall be furnished for roadways, special sewer and drainage structures, and shall contain details of thickness and type of materials, special bedding or reinforcement and relative locations and depths of utilities or other underground facilities requiring special consideration.

### **B. STANDARDS TO CONTROL EXCAVATIONS, CUTS, FILLS, CLEARING, GRADING, EROSION AND SEDIMENT**

#### TABLE OF CONTENTS

<u>SECTION</u>	<u>PAGE</u>
1 Scope and Intent	1
2 Definitions	1-6
3 General Provisions	6-8
4 Hazardous Conditions	8
5 Permit Applications and Requirements	8-11
6 Permit Exemptions	11-12
7 Fees	13
8 Sureties	13
9 Design Standards for Excavations	13-15
10 Design Standards for Fills	15-17
11 Design Standards for Cut and Fill Setbacks	17-18

12	Design Standards for Drainage and Terraces	18-20
13	Design Standards for Erosion and Sediment Control	20-25
14	Inspection and Compliance	25-26

**SECTION 1 SCOPE AND INTENT** These standards sets forth guidelines, rules, regulations, and minimum standard to control excavation, grading, clearing, erosion control, and maintenance, including cut and fill embankments; requires control of all existing and potential condition of accelerated erosion; requires protection of surface water quality by prevention of soil erosion and transport of soil sediments or other pollutants; establishes administrative procedures for issuance of permits; and provides for approval of Plans and inspections during construction and maintenance.

**SECTION 2 DEFINITIONS** When used in these standards, the following words shall have the meanings ascribed to them in this section:

- (a) “Accelerated Erosion” - Rapid erosion caused by human induced alteration of the vegetation, land surface topography, or runoff patterns. Evidence of accelerated erosion is indicated by exposed soils, active gullies, rills, sediment deposits, or slope failures caused by human activities.
- (b) “Access and Building Envelope” - An area delineated on the site plan within which all grading, clearing, and other disturbances for construction of access and/or building shall be confined.
- (c) “Applicant” - shall refer to a project or permit applicant (see “Permitee”).
- (d) “Bedrock” - In place, solid, undisturbed rock.
- (e) “Bench” - A relatively level step excavated into earth material on which fill is to be placed.
- (f) “Best Management Practice (BMP)” - A technique, series of techniques, or device which, when utilized in a designated manner, is proven to be effective in minimizing runoff and the quantity of pollutants that enter the storm drain system. Sedimentation and other products of erosion are considered pollutants to the storm drain system.
- (g) “Borrow” - Earth material acquired from an offsite or other onsite location for use in grading on a site.
- (h) “City Engineer” - The City Engineer or his/her designated representative is responsible for the administration and enforcement of these standards.
- (i) “Civil Engineer” - A professional Engineer registered in California to practice Civil Engineering works.
- (j) “Clearing” - The removal of vegetation and debris down to bare soil by any method.
- (k) “Compaction” - The densification of earth and solids or fill by mechanical means.

- (l) “Development Permit” - A permit is issued for new land use activities, minor land division, building, grading, land clearing, subdivision, planned unit development, and major plan development.
- (m) “Drainage Course” - A well-defined, natural or manmade channel, which conveys storm water runoff either year round or intermittently.
- (n) “Earth Material” - Rock, natural soil, or any combination thereof.
- (o) “Engineering Geologist” - A professional geologist registered in California to practice Engineering Geology.
- (p) “Erosion” - The wearing away of the ground surface by the actions of water, wind, ice, gravity, or a combination thereof.
- (q) “Erosion Hazards” - The susceptibility of a site to erode based on soils, condition and steepness of a slope, rock type, vegetation, and other site factors.
- (r) “Erosion Control Measures” - Design features and management practices intended to prevent soil, rock, or other material from being dislodged and moved down slope by storm water flows and wind.
- (s) “Excavation” - The mechanical removal of earth materials.
- (t) “Fill” - The deposit of earth materials by artificial means.
- (u) “Grade” - The vertical location of the ground surface or the degree of rise or descent of a slope.
  - (i) “Existing Grade” - The grade prior to any land disturbance or grading.
  - (ii) “Rough Grade” - An approximate elevation of the ground surface conforming to the proposed design.
  - (iii) “As Graded or Finished Grade” - The final grade which conforms to the approved Plan.
- (v) “Grading” - Any excavation, filling, leveling, or combination thereof (excludes stripping and/or clearing).
- (w) “Key” - A designed, compacted fill placed on a bench excavated in undisturbed earth material beneath the toe of a proposed fill slope to develop shearing resistance (see Figure 1).



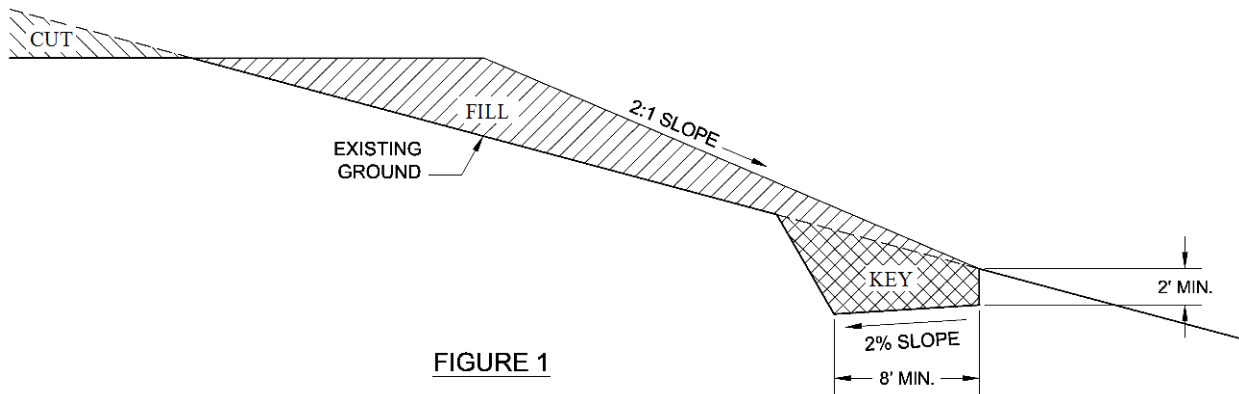

FIGURE 1

- (x) “Land Disturbance” - Clearing, excavating, grading, or other manipulation of the natural terrain.
- (y) “Low Impact Development (LID)” - means the stormwater management approach towards development planning and design that minimizes post-construction stormwater runoff pollutant loads and stormwater runoff quantity, by promoting infiltration and biofiltration, and minimizing the installation of impervious surfaces. The LID design orientation is to minimize the site stormwater runoff impact of development by using design techniques that infiltrate, filter, store, evaporate, and detain runoff close to its source.
- (z) “Notice of Intent” - The formal filing to the California State Regional Water Quality Control Board (RWQCB) for coverage under the NPDES General Construction Permit for Discharges of Storm Water Associated with Construction Activity
- (aa) “NPDES” – National Pollution Discharge Elimination System is a program, federally authorized by the Clean Water Act, which is aimed at reducing and eliminating pollution sources from entering into natural streams and bodies of water.
- (bb) “Owner” - The person or persons shown in the County Recorder’s Office as owner of property.
- (cc) “Permittee” - The owner, Contractor, or any person undertaking land disturbance activities upon a site pursuant to a permit granted by the City.
- (dd) “RWQCB - Regional Water Quality Control Board” - State regulatory agencies responsible for runoff water quality and the City of Salinas NPDES program.
- (ee) “Riparian and Wetland Resources” - Riparian and wetland resources are generally those areas which fall into one of the following categories:
  - (i) An area extending one hundred feet (100’) (measured horizontally) from each side of a perennial stream. Distance shall be measured from the one hundred (100) year flood high water mark.
  - (ii) An area extending one hundred feet (100’) (measured horizontally) from each side of an intermittent stream. Distance shall be measured from the one hundred (100) year flood high water mark.

- (iii) An area extending one hundred feet (100') from the one hundred (100) year flood high water mark of a marsh or a natural body of standing water.
- (ff) "Road Gradient (%)" - Vertical rise or distance multiplied by one hundred (100) and divided by horizontal run or distance.
- (gg) "Runoff" - The movement of surface water over land or improved surfaces such as, but not limited to, streets, parking lots, driveways, or sidewalks.
- (hh) "Sediment" - Eroded earth material that is carried by water, wind, gravity, or ice and deposited into channels, lakes, rivers, or other areas.
- (ii) "Sediment Control and Debris Facility" - A storm water treatment device facility such as a detention basin, which serves the purpose of collecting water-borne sediment and debris, and is designed to be cleaned periodically.
- (jj) "Sediment Control Measures" - Project design features intended to halt or reduce the movement or transport of soil sediments by storm water runoff or drainage flow.
- (kk) "Site" - A parcel of land or contiguous parcels where land disturbance including erosion control, clearing, grading, or construction are performed or proposed.
- (ll) "Slope" - An inclined ground surface the inclination of which is expressed as a ratio of horizontal distance to vertical distance.
- (mm) "Soil" - Naturally occurring mineral and organic earth materials on the immediate surface overlying bedrock or parent material.
- (nn) "Soils Engineer" - A Civil Engineer licensed in California who is experienced in soil mechanics and slope stability analysis.
- (oo) "Storm Water" - Drainage that has originated as rainfall, which then flows over land.
- (pp) "Storm Water Pollution Prevention Plan (SWPPP)" - Implementation Plan showing how the quality of storm water runoff shall be protected. Required for those projects under the General Permit for Discharges of Storm Water Associated with Construction Activity and as required by the City Engineer. The Plan generally a site map and specifically identifies the activities that have the potential to pollute storm water which could enter creeks or other natural drainage channels or the City's storm water drainage system, and describes the pollution prevention measures including Best Management Practices that shall be implemented at the site.
- (qq) "Stream" - Any watercourse as designated by a solid line or dash and three dots symbol shown on the largest scale of United States Geological Survey map most recently published.
- (rr) "State Water Resources Control Board" (SWRCB) - State agency to which the Regional Water Quality Control Boards report.
- (ss) "Ten (10) Year Storm" - A storm with such intensity and duration that its magnitude would only be exceeded on the average once every ten (10) years, or that has a ten percent (10%) chance of occurrence in any given year.

- (tt) “One hundred (100) year Storm” - A storm with such intensity and duration that its magnitude would only be exceeded on the average once every one hundred (100) years, or that has a one percent (1%) chance of occurrence in any given year.
- (uu) “Terrace” - A relatively level step constructed in the face of a graded slope surface for drainage and maintenance purposes.
- (vv) “Topsoil” - Loose, friable, organic, and fertile earth materials on top of a soil profile usually the A - horizon.
- (ww) “Waste Discharge Identification Number (WDID)” - Permit number issued by SWRCB for coverage under the General Construction Storm Water Permit.
- (xx) “Waterbreak” - A ditch, dike, dip, or combination thereof, constructed to effectively divert water as an aid to erosion control.

### **SECTION 3. GENERAL PROVISIONS.**

(a) No person shall cause or allow the persistence of a condition on any site that could cause accelerated erosion. Accelerated erosion shall be controlled and/or prevented by Permittee or the property owner by using measures outlined in subsequent sections as applicable, especially when work is on geologically unstable areas, on slopes above twenty percent 20%, and/or on soils rated as severe erosion hazard. Additional measures may be necessary and may be specifically required by the City Engineer.

(b) No person shall do or permit to be done any grading which may obstruct, impede or interfere with the natural flow of storm water, whether such waters are unconfined upon the surface of the land or confined within land depressions or natural drainage ways, unimproved channels or watercourses, or improved ditches, channels or conduits, in such manner as to cause flooding where it would not otherwise occur, aggravate any existing flooding condition or cause accelerated erosion.

(c) The property owner and the person(s) doing or causing or directing the grading are responsible for the prevention of damage to any other property, public health and safety. No person shall grade, fill, or excavate on any land so as to endanger any public street, sidewalk, alley, or any other public or private property, or public health and safety without supporting and protecting such property and persons from damage.

(d) The property owner and the person(s) doing or causing or directing the grading are responsible for protecting down-stream areas on or near the site, such as creeks, streams, wetlands, lakes, springs, trees, and riparian habitat that could be affected by the grading. The grading shall be conducted in a manner that prevents environmental damage and is consistent with the current versions of the City of Salinas Standard Specifications, Design Standards, and Standard Plans; the City of Salinas Storm Water Development Standards, as the same may be amended from time to time, and the requirements contain herein.

(e) The property owner and the person(s) doing or causing or directing the grading shall put into effect and maintain all Best Management Practices necessary to protect adjacent watercourses and public or private property from damage by erosion, flooding, or deposition of mud or debris originating from the site. Precautionary measures shall include provisions for properly designed erosion and sediment control measures, so that downstream properties are not

affected by upstream erosion or sediment transport by storm water. If, in the opinion of the City Engineer, grading activities result in a need for post-construction runoff control measures, then such measures, (including Low Impact Development devices/systems), shall be required to be installed, as specified in the City of Salinas Storm Water Development Standards.

(f) All construction projects that cause land disturbance of one (1) or more acres, or that disturb less than one (1) acre but are part of a larger common plan of development that in total disturbs one (1) or more acres, shall meet the applicable requirements of the State of California General Storm Water Permit for Discharges from Construction Activities and the City's NPDES permit. Applicants for grading permits shall submit a copy of the Notice of Intent (NOI) for application for coverage under the State Water Resources Control Board (SWRCB), General Construction Storm Water Permit, and the Waste Discharge Identification Number (WDID) issued by the SWRCB. A Storm Water Pollution Plan that meets the requirements of the State General Storm Water Permit shall be submitted to the City for approval for all construction projects required to obtain coverage. A grading permit shall not be issued without the NOI and WDID issued by the SWRCB and the approved SWPPP.

(g) The following minimum requirements apply to all construction projects that require coverage under the State General Construction Storm Water Permit:

- (i) Sediments generated at the project site shall be controlled using adequate source control and/or structural BMPs.
- (ii) Construction-related materials and wastes shall be retained at the project and properly disposed of to a void discharge to the City storm drain system and waters of the state.
- (iii) Unauthorized non-storm water runoff shall be contained at the project site. Authorized non-storm water discharges shall be as defined in the State General Construction Storm Water Permit.
- (iv) Erosion from slopes and channels shall be controlled by implementing an effective combination of erosion control (source control) and other BMPs as described in the City of Salinas Standard Specifications, Design Standards, and Standard Plans document, as the same may be amended from time to time, City of Salinas Storm Water Development Standards, and/or equivalent approved manuals that may be identified by the City.

(h) All construction projects shall implement the following BMPs, unless justification is provided and approved by the City in the SWPPP as to why it is not practicable.

- (i) Stabilized construction entrance;
- (ii) Scheduling of grading activities to minimize bare graded areas during the rainy season;
- (iii) Downslope sediment controls (e.g., sediment logs or equivalent);
- (iv) Concrete truck washouts;
- (v) Storm drain inlet protection;

- (vi) Protection of slopes and channels;
- (vii) Good housekeeping practices (e.g., trash management, proper material storage, and similar practices); and,
- (viii) Additional BMPs as may be designated by the City Engineer prior to issuance of the grading permit due to site conditions.

**SECTION 4. HAZARDOUS CONDITIONS.**

Whenever the City Engineer determines that an existing excavation, or embankment, or cut or fill has become a hazard to life or limb, or endangers property, or adversely effects the safety, use, or stability of a public way or drainage channel or causes significant impact on the natural resources of the area, the owner of the property upon which the excavation, embankment, cut, or fill, is located, or other person or agent in control of said property, upon receipt of notice in writing from the City Engineer shall, within the period specified therein, repair or eliminate such hazard and be in conformance with the requirements of these standards. Long-lived soil sterilants shall not be used on soils or slopes which may need subsequent revegetation for erosion and sediment control. Where feasible, erosion and soil sterility problems shall be corrected no later than the beginning of the next rainy season (approximately October 15).

**SECTION 5. PERMIT APPLICATION AND REQUIREMENTS.**

(a) General - Except as exempted in Section 6 of these Standards, a permit shall be obtained from the City by the owner(s) of the property (or agent when authorized in writing) for each site. Approval of a permit for a new development shall require the abatement of any existing human-induced or accelerated erosion problems on the property. Approval of the permit for construction sites of one (1) acre or more is also dependent on verification that a NOI for coverage under the State General Storm Water Construction Permit has been submitted and a WDID issued.

(b) Plans and Specifications - Two (2) sets of Plans, plus supporting data, shall be required for each application when required by the City Engineer. Plans shall be drawn to scale upon substantial material, minimum size 19" x 24", and shall be of sufficient clarity to indicate the nature and extent of the work proposed and show in detail that it shall conform to the Provisions of these Standards and all relevant laws and regulations. The first sheet of each set of Plans shall include the location and Assessor's Parcel Number(s) of work, the name, telephone number, and address of the owner(s), and the name, telephone number, and address of person by whom they were prepared. The Plans shall include the following information in writing, diagrams, and/or scale drawings:

- (i) Statements as to the specific intention or ultimate purpose for which the grading is being done.
- (ii) General location and vicinity of the proposed site.
- (iii) Property lines and accurate contours of the existing ground and details of terrain and area drainage without existing vegetation. Contour intervals shall be one foot (1') when the natural ground slope is less than five percent (5%); two (2') feet when five percent (5%) to ten percent (10%); and five feet (5') when slope

is more than ten percent (10%). Contours shall overlap fifteen feet (15') onto adjacent properties.

- (iv) Limiting dimensions, elevations, or finished contours to be achieved by the grading and proposed drainage channels and related construction, including proposed vegetation, landscaping, finished grade contours shall be shown as they relate to surrounding property contours.
- (iv) A comparison of runoff with project and without project may be required at the discretion of the City Engineer.
- (v) Detailed Plans and location of all temporary and permanent structural and non-structural erosion and sediment control measures, and of all surface and subsurface drainage devices, walls, cribbing, dams, sediment basins, storage reservoirs, and other protective devices to be constructed with, or as a part of, the proposed work, together with a map showing the drainage area with the complete drainage network and the estimated runoff of the area served by any drains. The location of any known erosion, flooding or inadequate capacity and condition of drainage courses and flood plains in the pathway of offsite runoff or drainage shall be noted on the Plans and/or maps.
- (vi) The planned direction and disposition of all storm drainage flow (with approximate grade) from all buildings, yards, lots, driveways, parking areas, and streets.
- (vii) Vegetative erosion control and re-vegetation measures for all surfaces exposed or expected to be exposed during grading activities.
- (viii) Locations of buildings or structures on the property where the work is to be performed and the approximate location of buildings or structures on adjacent lands owned by other owners which is within fifteen feet (15') of the property line, or which may be affected by the proposed operations.
- (ix) A statement of the approximate quantity of excavation and fill, along with the appropriate shrinkage factor.
- (x) Specifications, when required, shall contain information covering construction and material requirements.
- (xi) Estimated starting and completion dates.
- (xii) Extent and manner of tree cutting and/or vegetative clearing including a disposal Plan.
- (xiii) A provision for stockpiling topsoil when necessary for erosion control or landscaping.
- (xiv) North Arrow, written and graphic scales.

(c) Storm Water Pollution Prevention Plan (SWPPP) - Shall be submitted for construction sites of one acre (1 acre) or larger. At a minimum, the SWPPP shall address:

- (i) A vicinity map showing nearby roadways, the construction site perimeter, and the geographic features and general topography surrounding the site.
- (ii) A site map showing the construction project in detail, including the existing and planned paved areas and buildings; general topography both before and after construction; drainage patterns across the project area; and anticipated storm water discharge locations (i.e., the receiving water, a conduit to the receiving water, and/or drain inlets).
- (iii) A detailed, site-specific listing of the potential sources of storm water pollution.
- (iv) A description of the type and location of erosion and sediment control BMPs to be employed at the site.
- (v) The name and telephone number of the qualified person responsible for implementing the SWPPP.
- (vi) Certification/signature by the landowner or an authorized representative.

(d) Engineering Requirement - A Civil Engineer licensed by State of California shall prepare and sign the Plans and Specifications and be coordinator and liaison between other professionals, owners, Contractors, and the City Engineer if:

- (i) Grading is in excess of two thousand cubic yards (2,000<sup>cy</sup>) (excludes clearing and stripping).
- (ii) Major uses permits and/or any other projects likely to cause major land disturbances as determined by the City Engineer.

(e) Engineering Reports. When required by the City Engineer, each application for a permit shall be accompanied by two (2) sets of supporting data consisting of a soil and/or Civil Engineering report and/or Engineering Geology report, and/or any other reports deemed necessary by the City Engineer.

- (i) The Soils Engineering report shall include data regarding feasibility of the site for the proposed uses; recommendations for grading, including site preparation and placement of fill; nature, distribution, erosion hazards and strength of existing surface and subsurface soils; foundation recommendations; finished slope stability; design of buttress fills; recommendations for mitigation of seismic forces; surface and subsurface drainage; and soil description, as defined in the USDA Soil Survey of Monterey County, including soil types, depth, erodibility, and vegetative establishment and growing capabilities.
- (ii) The Civil Engineering report shall include hydrological calculations of runoff for ten (10) year and one hundred (100) year storm frequencies when required by the current City of Salinas Standard Specifications, Design Standards, and Standard Plans document; City of Salinas Storm Water Development Standards, and Section 12 of this Standards Specification; conclusions and recommendations for adequate erosion control and grading procedures, comparison of runoff without and within the project; design criteria for corrective measures, including the existing and/or required safe storm drainage

capacity of channels onsite and measures used to minimize impervious surface runoff; and opinions and recommendations covering a adequacy of site to be developed by the proposed grading.

- (iii) The City Engineering Geology report shall include an adequate description of the geology of the site, potential geologic hazard and conclusions, and recommendations regarding the effects of geologic conditions on the proposed development plus opinions and recommendations covering the adequacy and stability of the geologic subsurface for cuts and fill loads to be developed by the proposed grading.
- (iv) Recommendations included in the reports when approved by the City Engineer shall be incorporated in the Plans and Specifications.

(f) Variances - A request for variance from the Provisions of these Standards, the permit conditions, or the Plan Specifications may be approved, conditionally approved, or denied by the City Engineer. A request for a variance shall state in writing the Provision to be varied, the proposed substitute Provision, when it would apply and its advantages.

(g) Work Time Limits - The permittee shall fully perform and complete all the work required to be done within the time limits specified. If no time limit is specified, the permittee shall complete the work within one hundred and eighty (180) calendar days after the date of the issuance of the permit. If work has not started within one hundred and eighty (180) calendar days after the permit is issued, it expires.

If work authorized is started and suspended or abandoned for one hundred and eighty (180) calendar days, the permit also expires unless stoppage has been authorized in advance by the City Engineer.

If the permittee is unable to complete the work within the specified time he/she shall, prior to the expiration of the permit, present in writing a request for an extension of time, setting forth the reasons for the requested extension. If, in the opinion of the City Engineer, an extension is warranted, additional time may be granted for the completion of the work.

## **SECTION 6. PERMIT EXEMPTIONS.**

Excavation, grading, filling, clearing, and/or erosion control work requires a permit from the City except in the following:

(a) Subdivisions and Planned Unit Developments - When improvement Plans complying with these Standards have been approved.

(b) Building Pads and Driveways - Grading, when done with a valid building permit.

(c) Emergency Work - Work necessary to preserve life or property, provided, however, that when emergency work is performed under this section, the person performing it shall report the pertinent facts relating to the work to the City Engineer within ten (10) calendar days after commencement of the work. Thereafter the person shall obtain a permit pursuant to Section 29B-6 and perform such work as may be determined by the City Engineer to be reasonably necessary to correct any erosion or conditions with a potential to cause erosion as a result of the emergency work.



(d) Excavations - An excavation which does not exceed fifty cubic yards (50<sup>cy</sup>) and which is either less than two feet (2') in depth or which does not create a cut slope greater than five feet (5') in height and steeper than two (2) horizontal to one (1) vertical.

(e) Fill - A fill, except when in a riparian zone, containing permitted materials only which is less than two feet (2') in depth, is placed on natural terrain with a slope flatter than five (5) horizontal to one (1) vertical, does not exceed fifty cubic yards (50<sup>cy</sup>) on any site, does not alter or obstruct a drainage course, and shall not be used for structural support.

(f) Basements and Footings - An excavation below finished grade for basements and footings of a building, retaining wall, or other structure authorized by a valid building permit. This shall not exempt any fill except as provided under subsection (e) of this section, made with the material from such excavation nor exempt any excavation having an unsupported height greater than five feet (5') after the completion of such structures.

(g) Refuse Disposal - Refuse disposal bins which are permitted and actually being controlled pursuant to other City regulations, and excavations for individual and community sewage disposal systems made pursuant to other City permits.

(h) Wells and Utilities - Excavations for wells or utilities made pursuant to other City permits.

(i) Soil and/or Geological investigation - Exploratory excavations and/or test borings under the direction of either a soils Engineer or Engineering geologist where such excavation is to be returned to the original condition under the direction of such Engineer or geologist within forty-five (45) calendar days after the start of work.

(j) Agricultural Work - Use of land operated under a conservation plan by a resource conservation district. Routine plowing, harrowing, disking, listing, leveling, and similar operations necessary to prepare a field for a crop. Not exempted shall be initial grading to convert land from non-productive to crop producing use.

(k) Public Work - Work in connection with public improvement projects for which inspection is provided by the City or other public agency and which complies with these Standards.

## **SECTION 7. FEES.**

Fees, if any, necessary to implement this Standards Specification shall be as set forth per Section 11B-4 of the Salinas City Code.

## **SECTION 8. SURETIES**

(a) If grading is in excess of two thousand cubic yards (2,000<sup>cu</sup>), the permittee shall provide a cash deposit, bond, or equivalent surety, to the satisfaction of the City, payable to the City to insure compliance with the provisions of the permit and this Standards Specification. If deemed necessary by the City Engineer, a surety may be required for grading operations of less than two thousand cubic yards (2,000<sup>cu</sup>).

(b) Permits for grading shall not be valid and work shall not be started until the required sureties have been provided. Surety shall remain in effect one (1) full winter cycle from October 15 through April 15, after final inspection and approval by the City Engineer.

(c) All expenditures by the City for corrective work necessary because of the permittee's failure to comply with the provisions of the permit and this Standards Specification shall be charged against the surety.

(d) The amount of surety for grading shall be based on the number of cubic yards of material either excavation or fill, whichever is larger, plus the cost of drainage, erosion control, and/or other protective devices.

## **SECTION 9. DESIGN STANDARDS AND EXCAVATIONS.**

- (a) General - Unless otherwise recommended in the Soil Engineering and/or Engineering Geology reports approved by the City Engineer, cuts and excavations shall conform to the Provisions of this Section.
- (b) Slope - The slope of cut surfaces shall be no steeper than is safe for the intended use. Cut slopes shall be no steeper than two (2) horizontal to one (1) vertical, and shall not exceed twenty feet (20') in vertical height or exceed seventy-five feet (75') slope distance without a bench or terrace break. Due to individual site soils and geology, flatter and shorter slope lengths may be required, or steeper and longer slope lengths may be allowed when reviewed and found by the City Engineer to be consistent with building and safety. Cut slopes greater than three (3) horizontal to one (1) vertical shall only be permitted when installed with sufficient erosion control measures. Cut slopes shall be rounded off so as to blend in with natural terrain (see Figure 2).

### **ROAD CUTS AND FILLS**

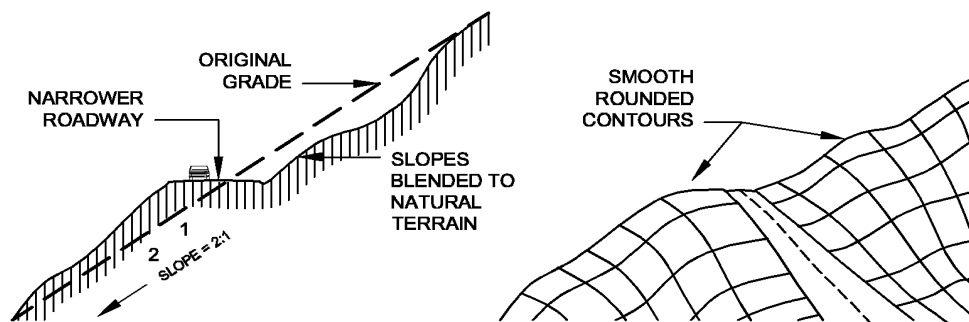

## DEVELOPMENT CUTS AND FILLS

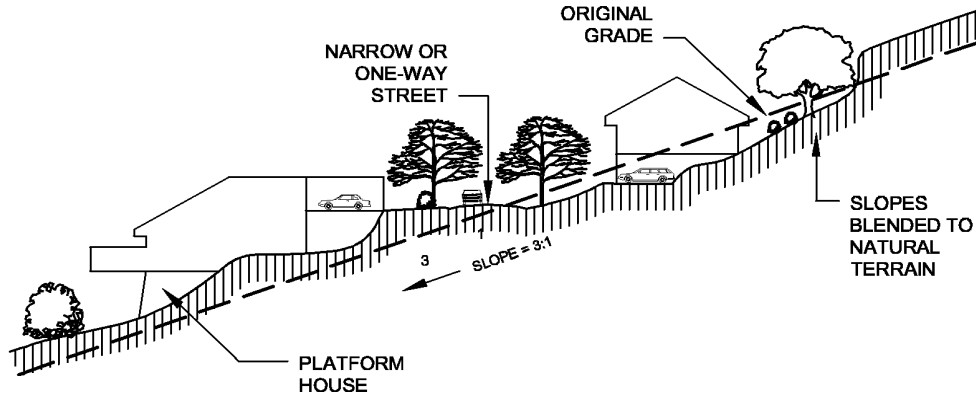

## MAXIMUM HEIGHTS AND LENGTHS OF CUT AND FILL SLOPES

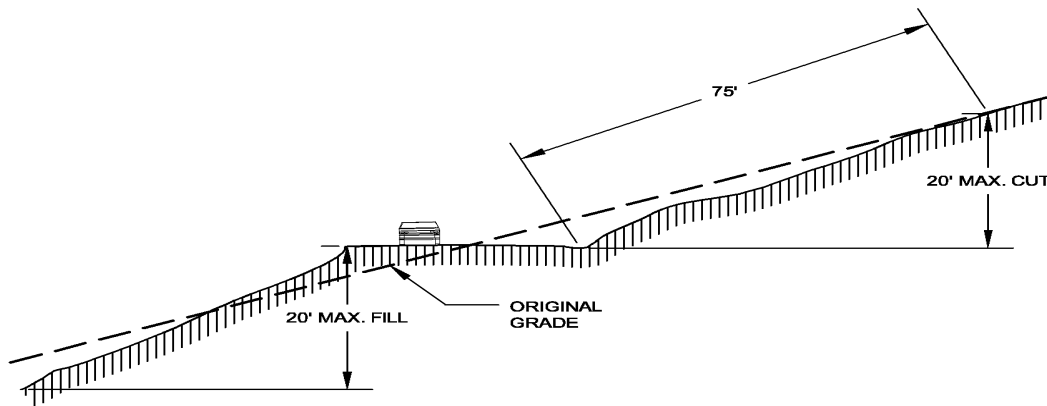

**FIGURE 2**

(c) Stockpiles - Stockpile material for trenches and pits shall be put up slope, when possible, of the excavation to be promptly backfilled and compacted into trenches and pits. Excavated material not needed at the site shall be removed or disposed of at a location and/or manner approved by the City Engineer.

(d) Vegetative Protection - All earth cuts shall be planted or otherwise protected from the storm runoff erosion within thirty (30) calendar days of the completion of final erosion control and grading work. Planting shall be irrigated to establish a root system before the rainy season, if necessary in the opinion of the City Engineer.

### **SECTION 10. DESIGN STANDARDS FOR FILL.**

(a) General - Unless otherwise recommended in the Soil Engineering and/or Engineering Geology reports approved by the City Engineer, fills shall conform to the Provisions of this Section.

(b) Fill Location - Fill shall not be constructed on natural slopes steeper than two (2) to one (1) unless an Engineer devises a method of placement which will ensure the fill shall remain

in place. Cut slopes greater than three (3) horizontal to one (1) vertical shall only be permitted when installed with sufficient erosion control measures. The toe of the fill shall be no closer than twelve feet (12') horizontally to the top of existing or planned cut slopes. The area beyond the toe of the fill shall be sloped for sheet overflow or a drain shall be provided (See Figure 3).

(c) Fill Slopes -The slope of fill surfaces can be no steeper than is safe for the intended use. Fill slopes shall be no steeper than two (2) to one (1) and shall not exceed twenty feet (20') vertical height or seventy-five feet (75') slope distance without a terrace break. Due to individual soil properties, shorter and flatter slopes may be required, or steeper and longer slopes may be allowed upon review by the City Engineer if he/she finds the deviations consistent with stability and safety. Tops of fill slopes shall be rounded off so as to blend with the natural terrain (See Figure 2).

(d) Ground Preparation - Natural ground surface over which fills are planned shall first be cleaned of all trash, vegetation, stumps, debris, non-complying fill, top soil, and other unsuitable materials and shall be scarified prior to the placement of the fill. Where slopes are three (3) to one (1) or steeper and/or twenty feet (20') or more in height, an eight foot (8') wide (minimum) key shall be dug into undisturbed, solid competent soil, or bedrock beneath the toe of the proposed fill. On minor fills, a key of less than eight feet (8') may be approved by the City Engineer. The key shall be cut and approved as a suitable foundation for fill before placing any fill (See Figure 1 and 3).

(e) Materials Permitted - Only approved material free from tree stumps, detrimental amounts of organic matter, trash, garbage, sod, peat and/or similar materials shall be used. Rocks, asphalt concrete, and/or broken concrete larger than six inches (6") in greatest dimension shall not be used unless the method of placement with appropriate technical analysis/justification is approved by the City Engineer. Topsoil may be used in the top twelve inch (12") surface layer to aid in planting and landscaping.

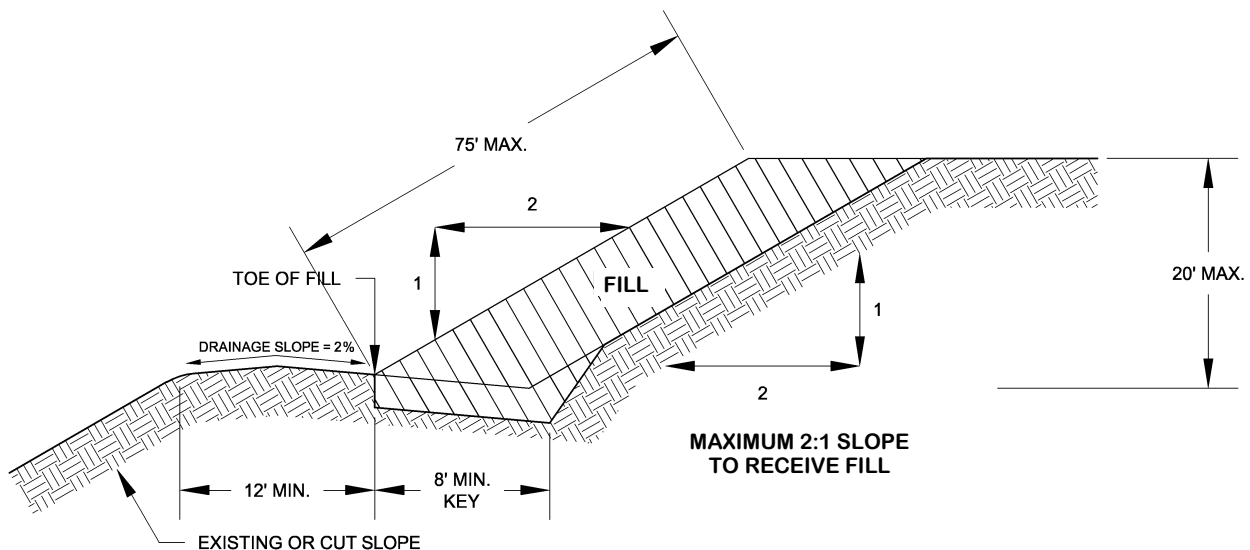

**FIGURE 3**

(f) **Compaction of Fill** - All fills shall be compacted to a minimum relative dry density of ninety percent (90%) as determined by ASTM D-1557-78 or CALTRANS test method under California 216. Field density verification shall be submitted for any fill twelve inches (12") or more in depth where such fill may support the foundation for a structure. A higher relative dry density and/or additional compaction tests may be required at any time by the City Engineer.

(g) **Vegetative Protection** - All earth fill shall be planted or otherwise protected from the effects of storm runoff within thirty (30) calendar days of the completion of final grading and plantings shall be irrigated to establish a root system, if necessary in the opinion of the City Engineer.

**SECTION 11 DESIGN STANDARDS FOR CUT AND FILL SETBACKS.**

(a) **General** - Unless otherwise recommended in the approved Soil Engineering and/or Engineering Geology reports and shown on the approved grading Plan, setbacks shall conform to this section and be no less than as shown in Figure 4.

(b) **Minimum Setbacks (Figure 4)** - Tops and toes of cut and filled slopes shall be set back from property boundaries and structures as far as necessary for the safety of the adjacent properties and to prevent damage resulting from water runoff, by flooding, erosion of the slopes, or by sediment deposition.

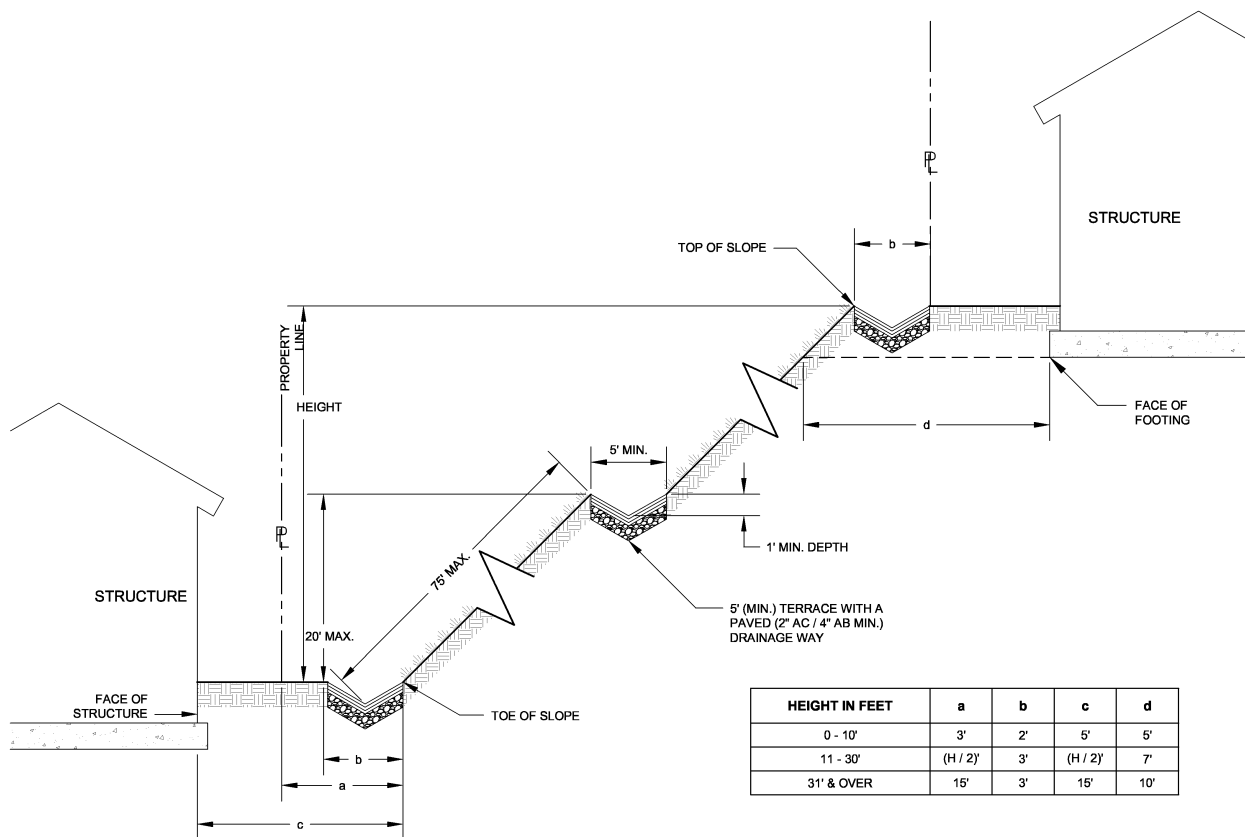

**FIGURE 4**

(c) **Stream and Riparian Setbacks** - Tops and toes of cut and/or filled slopes shall be set back, as designated and defined in the City's General Plan to provide and maintain a

undisturbed protective strip between the grading and the riparian corridor. This strip shall have sufficient filter capacity to prevent degradation of water quality as determined by a biologist approved by the City Engineer. If it is determined that the filter capacity of the protective strip is insufficient, additional erosion control may be required by increasing the width of the protective strip or with structural measures and/or by seeding, planting, mulching of bare soil areas.

(d) Retaining Walls - Retaining walls when keyed into stable foundations and capable of sustaining the design loads, may be used to reduce the required cut and fill setbacks when recommended by the Civil or Soil Engineers and approved by the City Engineer.

(e) Restrictions and/or minimums may be increased or relaxed upon review by the City Engineer if he/she finds the deviations consistent with safety and stability and to provide access for slope maintenance and drainageways.

## **SECTION 12. DESIGN STANDARDS FOR DRAINAGE AND TERRACES.**

(a) General.

- (i) Site designs shall incorporate measures for reducing runoff and water quality impacts in compliance with the current City of Salinas NPDES storm water permit and current City design standards. Drainage facilities and terraces shall conform to these Provisions. To the extent practicable, and as required by the City of Salinas Standard Specifications, Design Standards, and Standard Plans document, and the City's Storm Water Development Standards; peak storm drainage runoff and sediment rates may not exceed predevelopment rates. A pro-rata share of the cost of off-site erosion sediment, and flood control improvements and/or for maintenance to the principal drainageway may be required by the City Engineer to handle the increased peak runoff and/or sediment generated by the development if greater than predevelopment rates.
- (ii) All drainage facilities shall be designed to carry surface and subsurface waters to a street, storm drain, or watercourse, while minimizing the amount of said discharge. Adequate provisions shall be made to avoid damage to adjacent and downstream properties. All areas shall be graded and drained so that water shall not pond or accumulate.
- (iii) Drainage shall not cause downstream storm water quality degradation, erosion or endanger the stability of any cut or fill slope or any building or structure. If surface drainage is discharged onto any adjoining property, it shall be discharged in such a manner that it shall not cause erosion or endanger any cut or fill slope or any building or structure.

(b) Runoff Calculations - Plans and Specifications prepared for subdivisions of five acres (5 acres) or more, or as required by the current City of Salinas Standard Specifications, Design Standards, and Standard Plans document; and the City's Storm Water Development Standards, shall show, by table and/or calculations, the peak rates of storm runoff both before and after development for the ten (10) year and one hundred (100) year storms. Runoff calculations shall be performed according to the requirements of said standards. A combination of storage and controlled release of storm water runoff may be required by the City Engineer.

(c) Drainage Facilities.

- (i) Natural drainage ways shall not be disturbed and existing drainage courses shall not be obstructed or obliterated without mitigating measures installed that have been approved by the City Engineer. Grading equipment shall not disturb and/or cross a flowing stream unless absolutely necessary and only with prior approval from the City Engineer.
- (iii) Whenever a grading operation obstructs or impairs the flow of runoff in an existing drainage course, a culvert, bridge, or other suitable drainage facility designed and acceptable to the City Engineer shall be installed to convey the flow past the point of impairment. No construction materials or construction by-products shall be discarded in any drainageway or riparian zone.
- (iii) Where needed, drainage channels shall be culverts, pipe drains, paved, rock, or vegetative channels designed to safely carry existing and potential off-site runoff from a fully developed area upstream as well as local on-site surface and subsurface waters to an adequate drainage course designated for such purposes by the City Engineer. Properly designed energy dissipaters may be required at the point of discharge.
- (iv) Culvert size and industry standard materials shall be used in accordance with City Standard design criteria and as approved by the City Engineer. Minimum diameter shall be fifteen inches (15").
- (v) Cuts, fills, and retaining walls shall have subsurface drainage facilities as necessary for stability.
- (vi) Berms, ditches, interceptor drains, or swales, may be constructed at the top of cut and fill slopes when necessary for protection against water runoff. When required by the City Engineer, minimum size interceptor drains above cut slopes with a tributary drainage path greater than forty feet (40') measured horizontally or an area larger than one-third acre (1/3 acre) shall be constructed of an approved impervious non-erodible material a minimum of three inches (3") thick, one foot (1') deep, three feet (3') wide and discharge into down drains. Asphalt ditches shall not be allowed. Energy dissipaters may also be required by the City Engineer.
- (vii) At least a one percent (1%) grade shall be required toward an improved storm drainage facility, either existing or planned, from all building sites, pads, yards, roof drains, driveways, etc.
- (viii) Measures to control storm water runoff at the source shall be included in the grading Plan design.

(d) Terraces.

- (i) Terraces at least six feet (6') in width shall be established at not more than twenty foot (20') vertical intervals or seventy-five foot (75') slope intervals. Suitable access shall be provided to permit proper grading and maintenance of

these terraces. Where only one (1) terrace is required, it shall be at mid-height (see Figure 4).

- (ii) Swales or interceptor drains, ditches, on terraces, and on the top of cut slopes, shall be designed to carry water and sediment to safe disposal structures and areas and shall have a minimum appropriate gradient and shall be protected with an approved non-erodible material a minimum of three inches (3") thick, one foot (1') deep, and five feet (5') wide. A maintenance Plan may be required by the City Engineer.

### **SECTION 13. DESIGN STANDARDS FOR EROSION AND SEDIMENT CONTROL.**

(a) General - The following shall apply to the control of erosion and sediment from grading operations:

- (i) Grading Plans shall be designed with long-term erosion and sediment control as a primary consideration.
- (ii) No grading operations shall be conducted during the rainy season (October 15th - April 15th) except upon a clear demonstration, to the satisfaction of the City Engineer that adequate site erosion control measures are to be taken to minimize risk of increased erosion and sediment discharge from the site.
- (iii) Should grading be permitted during the rainy season, the smallest practicable area of erodible land shall be exposed at any one (1) time during grading operations and the time of exposure shall be minimized.
- (iv) Natural features, including vegetation, terraces, watercourses, and similar resources shall be preserved wherever possible. Limits of grading shall be clearly defined and marked to prevent damage by construction equipment.
- (iv) Permanent vegetation and structures for erosion and sediment control shall be installed prior to October 15th.
- (vi) Adequate provisions shall be made for long-term maintenance of permanent erosion and sediment control structures and vegetation.
- (vii) No topsoil shall be removed from the site unless otherwise directed or approved by the City Engineer. Topsoil overburden shall be stockpiled and redistributed within the graded area after rough grading to provide a suitable base for seeding and planting. Runoff from the stockpiled area shall be controlled to prevent erosion and resultant sedimentation of receiving water.
- (viii) Runoff shall not be discharged from the site in quantities or at velocities substantially above those which occurred before grading except into drainage facilities whose design has been specifically approved by the City Engineer.
- (ix) Permittees shall implement BMPs to ensure that vehicles do not track or spill earth materials into public streets and shall immediately remove such materials if this occurs.



- (x) Should increased erosion and sediment discharge occur or become imminent, permittees shall take all necessary steps to control such discharge. Such steps may include construction of additional facilities, or removal, or alteration of facilities required by a approved erosion and sediment control Plans. Facilities removed or altered shall be restored as soon as possible afterward or appropriate changes in the Plan shall be immediately implemented pursuant to this Standards Specification. Permittees shall take prompt action to resolve emergency problems.
  - (xi) If the project is abandoned after vegetation removal has taken place, the area shall be stabilized and planted as required herein. If the work is suspended for an extended period, the City Engineer may require interim planting as needed to control erosion and sediment transport.
- (b) Erosion and Sediment Control Plans: Erosion and sediment control Plans shall comply with the following requirements. For construction projects of one (1) acre or more that shall submit a SWPPP, the Erosion and Sediment Control Plan shall be incorporated as part of the SWPPP.
- (i) The erosion and Sediment Control Plans shall provide the location and description of all planned temporary and permanent erosion and sediment control measures, design and application standards specifications, and maintenance schedule.
  - (ii) Erosion and Sediment Control Plans shall be designed to prevent increased discharge of sediment at all stages of grading and development from initial disturbance of the ground to project completion. Every feasible effort shall be made to ensure that site stabilization is permanent. If grading occurs in distinct phases or the site shall remain unstable through more than one (1) rainy season, more than one (1) set of Plans may be required as determined by the City Engineer. Plans shall indicate the implementation period and the state of construction where applicable.
  - (iii) The structural and hydraulic adequacy of all storm water containment or conveyance facilities shown on the erosion and Sediment Control Plans shall be verified by a Civil Engineer, who shall so attest on the Plans. Sufficient calculations and supporting material to demonstrate such adequacy shall accompany the Plans when submitted.
  - (iv) Erosion and Sediment Control Plans shall include an effective re-vegetation program to stabilize all disturbed areas which shall not be otherwise protected.
  - (v) Erosion and Sediment Control Plans shall be designed with sufficient flexibility to meet unanticipated field conditions.
  - (vi) Erosion and Sediment Control Plans shall provide for inspection and repair of all Erosion and Sediment Control facilities at the close of each working day during the rainy season and for specific sediment cleanout and vegetation maintenance criteria.

- (vii) Erosion and Sediment Control Plans shall comply with the recommendations for BMPs as described in the City of Salinas Stormwater Development Standards and the City's Standard Specifications, Design Standards, and Standards Plans document, as the same may be amended from time to time, City of Salinas Storm Water Development Standards, and/or equivalent approved manuals that may be identified by the City and any civil engineer, geotechnical engineer, engineering geologist, or landscape architect involved in preparation of the Grading Plans.
  - (viii) The City Engineer may, in his/her sole discretion, waive the requirement for an Erosion and Sediment Control Plan if, in his/her opinion no significant erosion or sediment discharge hazard exists. The requirement for a SWPPP for applicable sites (one (1) acre or larger) cannot be waived.
- (c) Erosion and Sediment Control Requirements. The following requirements for erosion and sediment control shall apply.
- (i) General - Access and building envelopes shall be delineated on the development Plans when necessary to keep disturbance out of particularly erodible areas. New lots shall not be created which shall require access road and driveways to cross slopes exceeding twenty percent (20%) five to one (5 to 1) for distances greater than fifty feet (50'), unless adequate mitigation measures are provided. Exposed soils shall be protected from erosion by temporary and/or permanent measures, as approved by the City Engineer.
  - (ii) Slope - Structures on existing slopes exceeding twenty percent (20%) shall utilize pole, step, or other such foundation that does not require major land disturbance (See Figure 2).
  - (iii) Runoff Control - Where concentrated runoff shall occur, it shall be carried in pipe or culvert conduits or over a non-erodible surface (paved, rocked, or vegetated) with discharge points clearly shown on the Development Plans. When necessary to prevent erosion, conduits shall have proper energy dissipaters at the point of discharge.
  - (iv) Protection of Down Slopes - Best Management Practices shall be implemented to minimize damage to the face of cuts and fills. Down slopes shall be protected from surface water runoff from above by dikes, swales, or cut-off ditches, or other measures, as needed.
  - (v) Building Site Runoff - Runoff from buildings, roads, driveways, and the total site areas shall be controlled by berms, swales, ditches, structures, vegetative filter strips and/or catch basins to adequately reduce the escape of sediment from the site.
  - (vi) Sediment and Debris Control Facilities - Temporary and permanent sediment and debris control facilities shall be installed whenever and wherever necessary to protect the project and downstream properties from erosion and sediment/debris discharge.

- (vii) Vegetative Removal - Development Plans shall indicate the areas where vegetation is to be removed and replaced within the building and access envelopes. Vegetation removal shall be limited to that area necessary and as indicated on the approved Development Plan. The method and times shall be such that the erosive effects are minimized.
  - (viii) Vegetative Disposal - Vegetation removed during clearing operations shall be disposed of by chipping, used as mulch, compost, and/or disposed off site in a manner approved by the City Engineer.
  - (ix) Topsoil - To promote regrowth of vegetation, the topsoil shall be stockpiled and reapplied upon completion of grading on slopes of less than twenty percent (20%). Soil stockpiles and exposed soils shall be protected from erosion at all times. Excess topsoil shall be disposed off site in a manner approved by the City Engineer.
  - (x) Temporary Vegetation - Temporary vegetation sufficient to stabilize the soil as permanent vegetation covers maturing shall be established on all disturbed areas as needed and as each stage of grading is completed.
- (d) Winter Operations - October 15 to April 15.
- (i) Grading projects that are started but not completed by October 15 of each year are to be "winterized" by installation of planned erosion and sediment control measures, which shall be maintained in good repair through the following April 15, and until the project is completed.
  - (ii) During the period of October 15 to April 15, or other dates as determined by the City Engineer, all planned erosion and sediment control measures shall be installed prior to start of grading operations, unless approval for phased control measure installation is requested of and granted by the City Engineer prior to grading or construction permit issuance.
  - (iii) When work is allowed, existing ground cover shall not be cleared, destroyed, or disturbed more than fifteen (15) calendar days prior to grading or construction work unless approved in advance by the City Engineer.
  - (iv) When land development work is allowed during the normal, rainy winter season, adequate erosion and sediment control measures shall be in place during any land disturbance, and temporary erosion control measures, when needed, shall be applied to all soils bared at the end of each day.
  - (v) During winter, sufficient erosion control materials of straw, plastic, netting, etc., shall be kept on the site at all times to be installed immediately by the permittee upon advent of any rainfall or wind that may be expected to cause erosion and sediment discharge.
  - (vi) All major cut and fill slopes within the access and building envelope without established vegetation shall be adequately protected between October 15 and April 15 by mulching or other methods approved by the City Engineer.

- (vii) All erosion and sediment control measures, including plantings and mulching, shall be closely monitored throughout the winter and runoff problems corrected promptly. Mulching shall be anchored by punching or tacking into the soil or by the use of netting. A minimum of one thousand pounds (1000lbs). Of straw, or equivalent, per each ten thousand square feet (10,000<sup>sf</sup>) of slope surface shall be required to be anchored. An additional amount may be required by the City Engineer. All erosion and/or slippage of banks shall be repaired by the permittee at his/her expense.
- (viii) Within ten (10) working days after seeding, fertilizing, and/or mulching, the permittee shall commence watering of the seeded areas or slopes and shall continue until the rains come and/or the ground cover is fully developed and/or self-sufficient. All control measures including berms, diversion catch basins, sediment traps, etc., shall be installed prior to seeding and mulching.
- (e) Dust - Dust from grading operations shall be controlled. Dust control shall consist of applying water or other dust palliatives, or covering small stockpiles or areas, as necessary to prevent or alleviate dust nuisance generated by construction activities. Periodic street sweeping may also be required by the City Engineer.
- (f) Sediment Tracking Control - Sediment shall be prevented or controlled from being tracked off-site by vehicles leaving the construction area using appropriate Best Management Practices such as stabilized construction entrances/exits, stabilized construction roadways, and entrance/exit tire washes.
- (g) Erosion and Sediment Control Coordination with Project Installation.
  - (i) All vegetative and/or structural measures required to safely discharge any runoff generated by the project shall be installed during the first or initial construction phase of the project.
  - (ii) Land shall be developed in increments of workable size which can be completed in a single construction season. Erosion and sediment control measures shall be coordinated with a sequence of grading, development, and construction operations, and all necessary erosion control measures shall be put in effect prior to the commencement of the next work increment and/or winter rainy season.
  - (iii) Prior to completion and final acceptance of the project, all erosion control measures shall be in place and all exposed bare soil shall be mulched, fertilized, and otherwise prepared so that it is planted to a permanent vegetative cover. Native or naturalized vegetation should be used. The City Engineer may require watering of planted areas to initiate and assure growth.
- (h) Livestock - Where necessary to assure that water quality is not affected by the keeping of livestock, vegetative buffer, and/or filter strips shall be established on all downhill sides of areas where livestock are kept. The width of the buffer strip shall be determined by the City Engineer. Also, additional erosion control measures, such as diversion, dissipaters, and sediment basins may be required to control runoff from these areas where livestock have destroyed and torn up protective vegetation.

- (i) Maintenance - All on-site erosion control facilities shall be properly maintained by the owners for the life of the project so that they do not become nuisances with stagnant water, heavy algae growth, insect breeding, odors, discarded debris, and/or safety hazards. Vegetative maintenance required may include mowing, fertilization, irrigation, and/or reseeding.
- (j) Storm Drain Inlets' Sediment shall be prevented from entering the storm drainage system by implementing approved storm drain inlet Best Management Practices.

**SECTION 14. INSPECTIONS AND COMPLIANCE.**

(a) General - Excavation, grading, filling, clearing, and erosion and sediment control work requiring a permit shall be subject to inspection by the City Engineer. In lieu of inspection by City staff employees, the City Engineer may require supervision, regular inspection, and special testing be performed, together with a letter of compliance by the licensed professional who prepared the approved Plan; or the City Engineer may require supervision inspection, and testing, together with a letter of compliance submitted by an approved independent testing agency.

(b) Inspections Required - The following inspections shall be required:

- (i) Periodic ongoing inspection during project progress, including compaction and special testing as may be required by the approved Plan.
- (ii) Final inspection determining compliance with terms and conditions of these standards and permit.

(c) Compliance with Storm Water Pollution Prevention Plan Requirements for Construction Sites - Periodic inspections shall include inspection for compliance with implementation of storm water pollution prevention Best Management Practices, as required by approved SWPPPs and City ordinances, including the Storm Water Management and Discharge Control Ordinance and the City's NPDES permit. Enforcement of storm water pollution prevention compliance shall be as stated in the Storm Water Discharge and Control Ordinance.

(d) Notification - The permittee shall notify the City Engineer two (2) working days prior to the beginning of the operation authorized by the permit, and one (1) complete working day prior to any inspection or testing requested by the permittee.

(e) Right of Entry - Filing of an application for a permit under these standards constitutes a grant of permission for the City to enter the permit area for the purpose of administering these Standards from the date of the application to the termination of the erosion control maintenance period. If necessary, the City Engineer shall be supplied with a key or lock combination, or permitted to install a City lock.

A Site Grading Plan shall also be furnished, together with the Development Plans for review. Site grading shall be in accordance with the requirements of Resolution No. 19244 ( NCS) "Standards to Control Excavations, Cuts, Fills, Clearing, Grading, Erosion and Sediment".

Standard construction details may be referenced by note to specific City Standard Plans and Special Provision Sections.

The developer/owner shall conform to Section "V". Development Plan Checklist for requirements with the initial submittal package.



# **CITY OF SALINAS**

## **DEVELOPMENT AND ENGINEERING SERVICES DEPARTMENT**

### **PART III**

#### **S T A N D A R D   P L A N S**

Part III Standard Plans contain only units in the United States Standard Measures (USSM). The measurements expressed in this Part III are to be used for design calculations only. Final Plans and Specifications shall be in USSM as approved by the City.





# PART III

## STANDARD PLANS

### TABLE OF CONTENTS

<i>Standard Plan No.</i>	<i>Title Description.</i>
1	Curbs and Gutters
2R	Sidewalk and Curb Returns <i>Updated 3-7-17</i>
3	Street Structural Sections
4A	Type "A" and Type "B" ADA Pedestrian Access Ramps
4B	Type "C" and Type "D" ADA Pedestrian Access Ramps
5	Driveway Approach
6	Driveway Approach for Roll Type Curb
7	Alley Approach and Section
8	City Monument
9	Benchmark for Elevation Control
10	Tree Well
11	Street Tree Planting
12	Raised Median Island Standard Construction Plan
13	Raised Median Island Standard Planting Plan
14	Median Island Details
15	Pork Chop Island and Reflective Marker
16	Trench Backfill and Surface Restoration
17	Cast-In-Place Concrete Pipe
18	Miscellaneous Storm Drain Details
19	Curb Drain
20	Storm Drain Marker Installation
21	Type "A" Catch Basin
22	Type "D" Side Opening Catch Basin
23	Type "E" Top Opening Catch Basin
24	Type "F" Catch Basin
25	Type "A" and "B" Manhole
26	Type "C" Manhole (Shallow Type)
27	Manhole Frame and Cover
28	Manhole Frame and Cover Adjustment
29	Sewer Saddle Connection
30	Flushing Inlet Frame and Cover
31	Flushing Inlet
32	Sewer Lateral (V.C.P.)
33	Fire Hydrant Location
34	Fire Hydrant Construction
35	Valve Box Installation
36	Double Check Valve - Back Flow Preventer Assembly and Installation
37A	Thermoplastic Striping
37B	Thermoplastic Striping
38	Fire Hydrant Pavement Marker Location
39	Pavement Marking Legends And Words

} *Canceled 3-7-17 Ref. CT'  
Std. Plans 488A & 488B*

## TABLE OF CONTENTS (PART III STANDARD PLANS) - Continued

40	Pavement Marking Arrows
41	Bike Lane
42R	Off Street and On Street Accessible Parking ( <i>Updated 3-7-17</i> )
43	Limit Line Installation
44R	Crosswalk ( <i>Updated 3-7-17</i> )
45	Channelization Devices
46	Typical Lane Closure
47	Street Name Sign
48	Traffic Signs (Stop/Yield)
49	P.C.C. Lighting Foundation
50	Fuse Connector
51	Street Light Base Details and Pullbox Installation
52	Street Light Pole and Number Location
53	Pullbox
57	Chain Link Fence
58	Masonry Non-Access Wall
59	Wooden Rail Barricade
57A	Standard Trash Enclosure
57B	Standard Trash Enclosure Details
58	Slope Grading
59A	Best Management Practices
59B	Concrete Waste Washout Management Plan

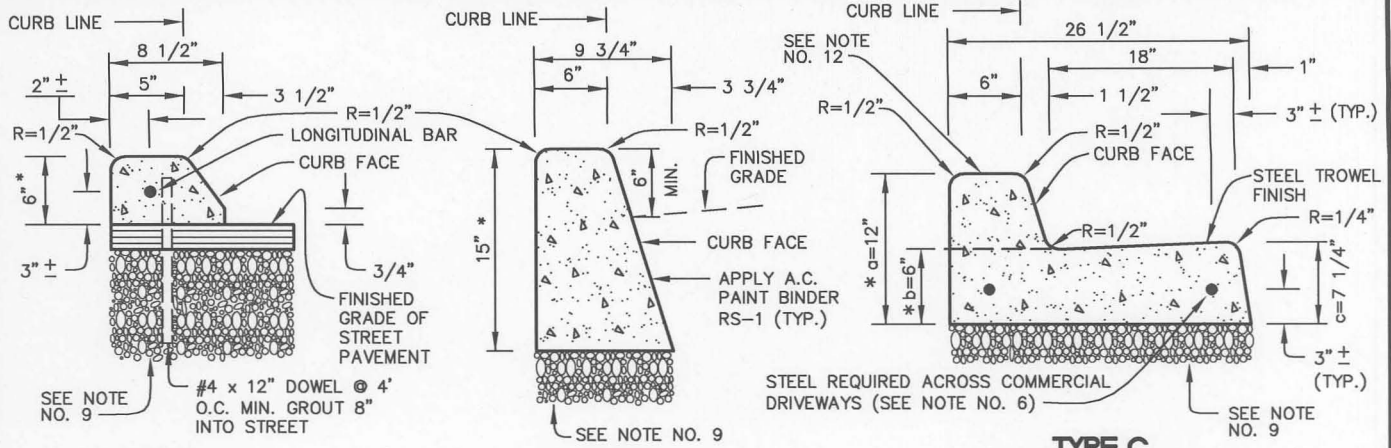

**TYPE A**

**TYPE B**

**TYPE C**

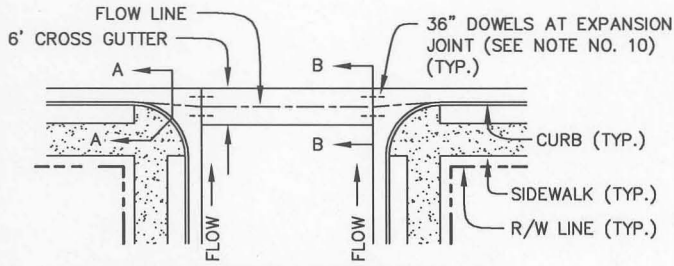

**TYPICAL CROSS GUTTER DETAIL**

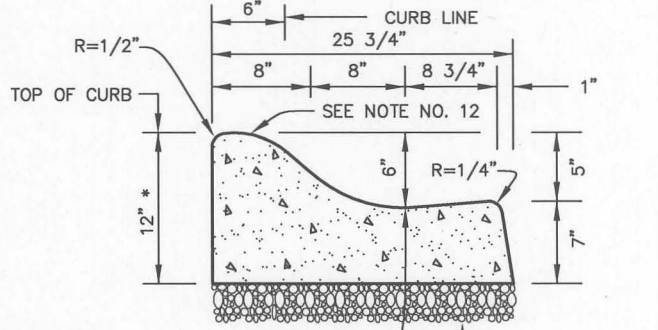

**STANDARD ROLL CURB**

**GENERAL NOTES**

\* NOMINAL DIMENSION BACK-FORM MAY BE USED EXCEPT IN INDUSTRIAL AREAS

1. DRAWING NOT TO SCALE.
2. ALL WORK SHALL BE DONE IN ACCORDANCE WITH SECTION 73 OF THE CITY STANDARD SPECIFICATIONS.
3. EXPANSION JOINTS SHALL BE SLIP DOWELED AT CURB RETURNS (SEE CITY STANDARD PLAN NO. 2).
4. TOP AND FRONT OF ALL CURBS SHALL BE FINE BROOM FINISHED.
5. CURB RETURNS SHALL BE TYPE "C" EXCEPT ADJACENT TO CROSS GUTTERS, WHERE MODIFIED TYPE "C" CURB AND APRON SHALL BE USED.
6. CURB AND GUTTER AT COMMERCIAL DRIVEWAYS SHALL HAVE 2 #4 BARS INSTALLED FOR THE WIDTH OF THE DRIVEWAY (HEAVY DUTY TYPE "C" CURB AND GUTTER).
7. INSTALL 3/8" EXPANSION JOINTS AT 20' INTERVALS MAX. ON TYPE "C" CURB. PROVIDE WEAKENED PLANE JOINTS AT 10' INTERVALS WITH EXPANSION AT 60' INTERVALS ON EXTRUDED CURB (SEE CITY STANDARD PLAN NO. 2).
8. CLASS "3" CONCRETE PER CITY STANDARD SPECIFICATIONS SHALL BE USED.
9. 6" MINIMUM CLASS 2 A.B. OR HIGHER TYPE SHALL BE USED FOR BASE MATERIALS.
10. CROSS GUTTERS SHALL HAVE TWO #4 x 36" LONG STEEL DOWELS AT MID-DEPTH CENTERED AT EXPANSION JOINT. FOR SLIP DOWEL DETAIL SEE CITY STANDARD PLAN NO. 2.
11. AN ADHESIVE APPROVED BY THE CITY ENGINEER MAY BE USED IN LIEU OF DOWELS IN TYPE "A" EXTRUDED CURB FOR PLACEMENT ON EXISTING PAVEMENT. OMIT HORIZONTAL STEEL IN EXTRUDED CURB (EXCEPT ACROSS COMMERCIAL DRIVEWAYS).
12. CONTRACTOR SHALL STAMP TOP OF CURB WITH THE LETTERS "G" (GAS), "S" (SEWER), AND/OR "W" (WATER) TO IDENTIFY UTILITY SERVICE LOCATIONS.
13. WITHIN INDUSTRIAL AREAS SUBJECT TO HEAVY TRUCK TRAFFIC, THE CONCRETE THICKNESS SHALL BE a=14", b=8", AND c=9 1/4".

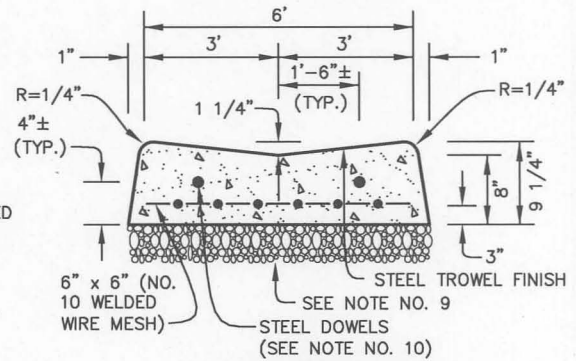

**SECTION B-B**

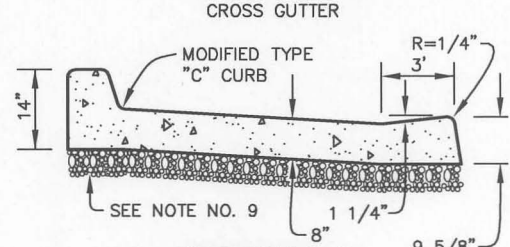

**SECTION A-A**

**DEVELOPMENT & ENGINEERING SERVICES DEPARTMENT**

ENGINEERING SERVICES DIVISION

CITY OF SALINAS

TITLE: **CURBS AND GUTTERS**

**STANDARD PLAN**

DESIGNED BY:  
STAFF  
CADD BY:  
STAFF  
PROJECT MANAGER:  
FRANK A. AGUAYO, P.E.

DATE 10/21/2008  
*Robert C. Russell*  
ROBERT C. RUSSELL, CITY ENGINEER  
R.C.E. 42871, EXPIRES 3-31-2010



**1**

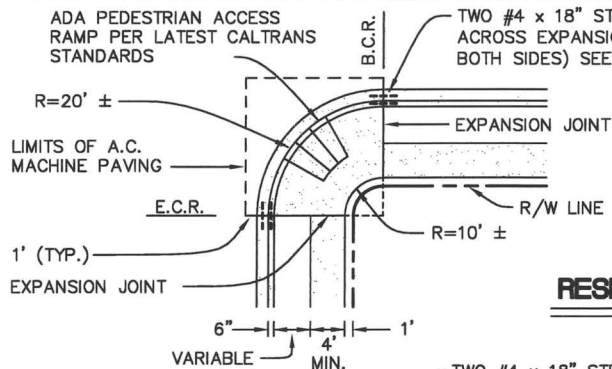

### RESIDENTIAL STANDARDS

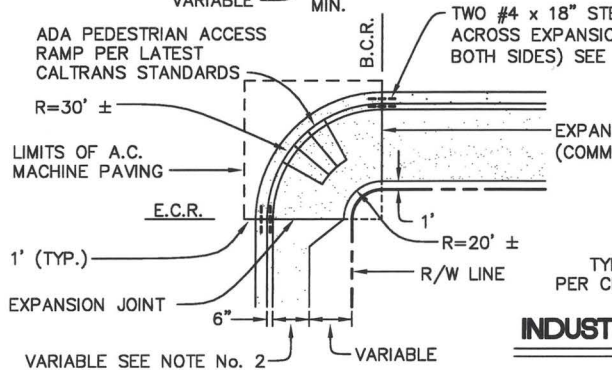
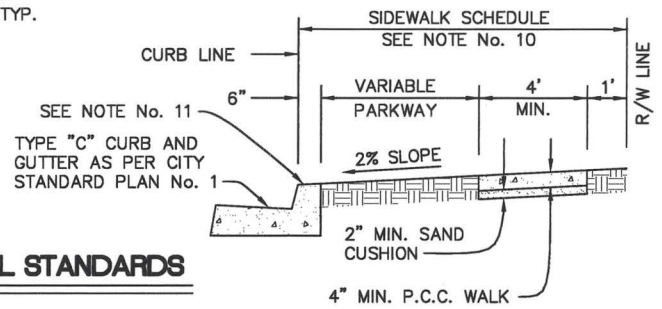

### INDUSTRIAL-COMMERCIAL STANDARDS

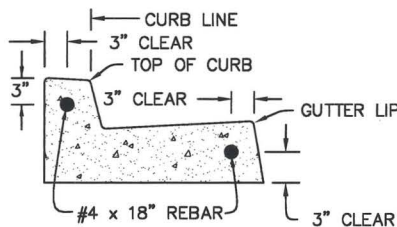
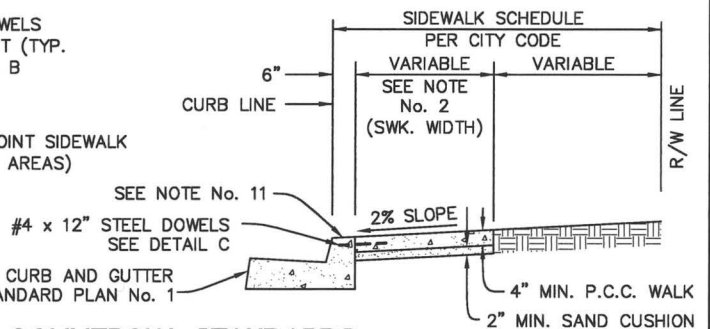

### DETAIL 'B'

TYPICAL DOWEL DETAIL AT CURB RETURNS

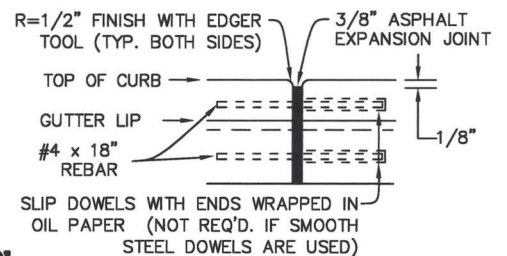

### DETAIL 'A'

TYPICAL SIDEWALK EXPANSION JOINT

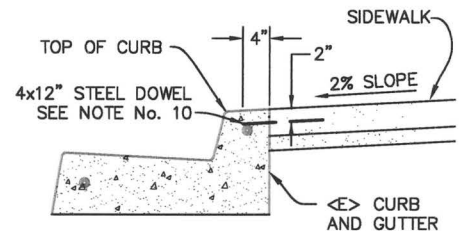
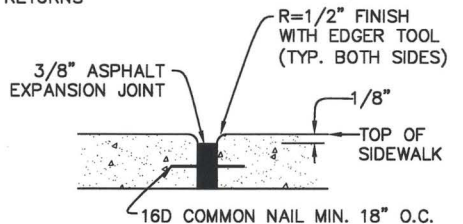

### DETAIL 'C'

TYPICAL DOWEL DETAIL AT CURB/SIDEWALK

### GENERAL NOTES

- DRAWING NOT TO SCALE.
- CONCRETE SIDEWALK SHALL BE 8.5' MINIMUM IN COMMERCIAL AREAS AND 5.5' MINIMUM FOR INDUSTRIAL AREAS. A 6' SIDEWALK CAN BE USED IN COMMERCIAL AREAS UPON APPROVAL OF THE CITY ENGINEER. ALL SIDEWALKS SHALL HAVE A MINIMUM 4' CLEAR PASSAGE, FREE OF OBSTRUCTIONS AND/OR HINDRANCES, AS OUTLINED IN TITLE 24 OF THE CALIFORNIA BUILDING CODE.
- ALL SIDEWALKS SHALL BE ONE COURSE, CLASS "3" P.C.C. WITH A FINE BROOM FINISH.
- ASPHALT EXPANSION JOINTS SHALL BE PLACED WITH MAXIMUM SPACING OF 60' AND WHEREVER SIDEWALK ADJOINS EXISTING BUILDING OR SIDEWALK. SCORE LINES SHALL BE PROVIDED FOR EVERY 16 TO 22 S.F. AT 4' INTERVALS AND PROPORTIONAL OR AS DIRECTED BY THE CITY ENGINEER.
- ASPHALT EXPANSION JOINT SHALL BE COMPOSED OF ASPHALT, FIBER, AND MINERAL FILLER REMOLDED INTO SHEETS WITH ASPHALT IMPREGNATED LINERS ON BOTH SIDES AND SHALL CONFORM WITH ASTM 1751 AND AASHTO M-33-48 SPECIFICATIONS.
- REBAR SHALL BE INSTALLED PER DETAIL "B" AT B.C.R. AND E.C.R.
- CONTRACTOR SHALL STAMP HIS/HER NAME, MONTH, AND YEAR OF CONSTRUCTION ON SIDEWALK, WITH A MINIMUM OF ONCE PER CONSTRUCTION AND ONCE PER EACH 500 S.F., MONTH AND YEAR MAY BE STAMPED IN NUMBERS.
- ALL DIMENSIONS AS SHOWN UNLESS OTHERWISE SPECIFIED ON PLANS.
- ADA PEDESTRIAN ACCESS RAMP SHALL BE PER LATEST CALTRANS STANDARDS.
- SIDEWALKS LOCATED ADJACENT TO CURB, SHALL HAVE DOWELS BETWEEN CURB AND SIDEWALK REQUIRED AT 12' ON CENTER.
- CONTRACTOR SHALL STAMP TOP OF CURB WITH THE LETTERS "G" (GAS), "S" (SEWER), AND/OR "W" (WATER) TO IDENTIFY UTILITY LOCATIONS.

### PUBLIC WORKS DEPARTMENT

ENGINEERING SERVICES DIVISION

CITY OF SALINAS

### TITLE: SIDEWALKS AND CURB RETURNS

### STANDARD PLAN

DESIGNED BY:  
STAFF

CADD BY:  
STAFF

PROJECT MANAGER:  
EDA HERRERA P.E.

DATE 2/3/2017

*[Signature]*

FRANCISCO A. AGUAYO,  
CITY ENGINEER, R.C.E. 59378



# 2R



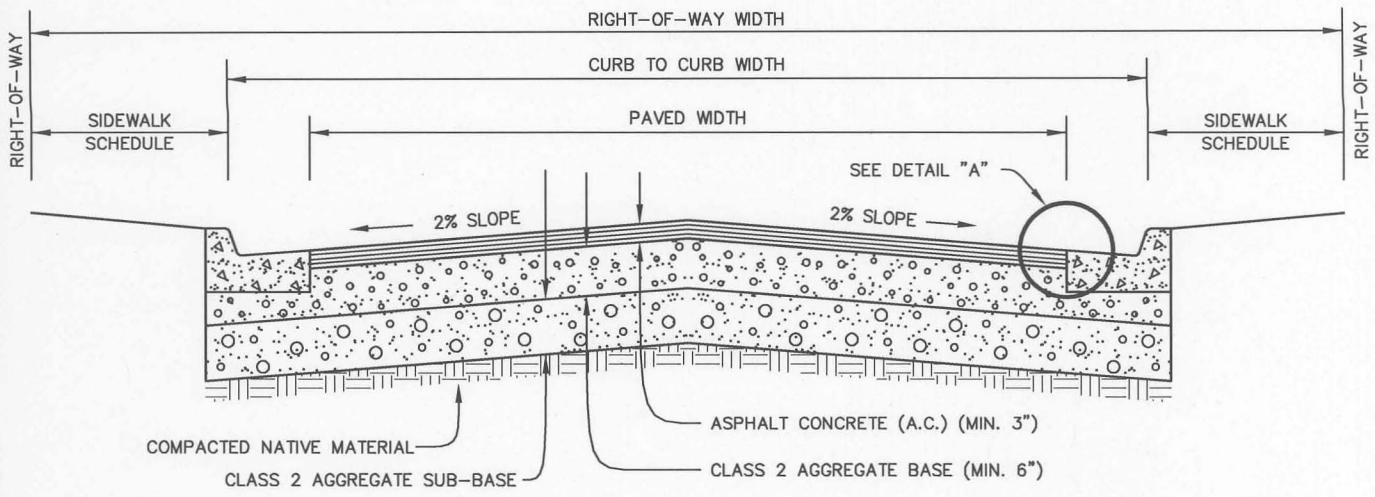

**TYPICAL CROSS SECTION**  
FLEXIBLE PAVEMENT

STANDARD PAVEMENT SECTIONS			
TI	AC	AB	A S B
5	3.0"	6"	SHALL MEET SUBGRADE R-VALUES SECTION REQUIREMENTS PER CALTRANS STANDARDS
6	3.0"	6"	
7	4.0"	8"	
8	4.5"	8"	
9	5.5"	10"	
10	6.5"	10"	

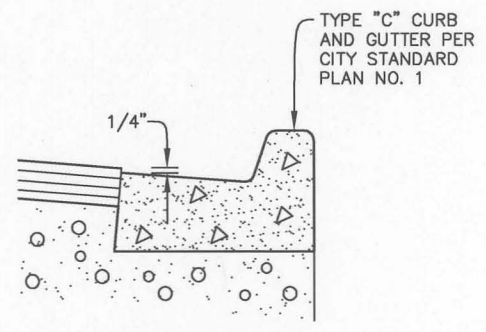

**DETAIL 'A'**

**GENERAL NOTES**

- DRAWING NOT TO SCALE.
- STREET RIGHT-OF-WAY WIDTHS AND SIDEWALKS SCHEDULES SHALL BE BASED UPON CURRENT CITY STANDARDS FOR DESIGNATION OF STREET CLASSIFICATIONS.
- PAVEMENT STRUCTURAL SECTIONS SHALL BE DETERMINED BY THE CALTRANS FLEXIBLE PAVEMENT DESIGN METHODS BASED UPON THE R-VALUES OF SUBGRADE MATERIALS AND THE TRAFFIC INDEX. IN NO CASE SHALL FLEXIBLE PAVEMENT SECTIONS BE LESS THAN 3" OF ASPHALT CONCRETE OVER 6" OF AGGREGATE BASE.
- R-VALUE TESTS ON SUBGRADE MATERIALS SHALL BE PERFORMED BY THE DEVELOPER'S SOIL ENGINEER; THE RESULTS AND PAVING SECTIONS SHALL BE APPROVED BY THE CITY ENGINEER.
- TRAFFIC INDEX (TI) VALUES FOR COLLECTOR, INDUSTRIAL, AND ARTERIAL STREETS SHALL BE BASED UPON PROJECTED 20 YEAR VOLUMES AND SHALL BE IN ACCORDANCE WITH THE CITY SUBDIVISION ORDINANCE FOR THE VARIOUS STREET CLASSIFICATIONS.
  - CUL-DE-SACS OR OTHER SINGLE ENTRANCE STREETS WHICH PROVIDE ACCESS TO A MAXIMUM 16 DWELLING UNITS (AT FULL DEVELOPMENT) SHALL BE ASSIGNED A MINIMUM TRAFFIC INDEX OF 5.
  - A MINIMUM TRAFFIC INDEX OF 5 SHALL BE ASSIGNED TO OTHER STANDARD RESIDENTIAL STREETS WITH 2 OR MORE ENTRANCES.
  - OTHER STREETS WHICH SERVE AS A COLLECTOR STREET, ARTERIAL STREETS OR OTHER STANDARD STREET DESIGNATION SHALL BE ASSIGNED TRAFFIC INDEX VALUES BY THE CITY ENGINEER, IN ACCORDANCE WITH SECTION 31 OF THE SALINAS CITY CODE.
- FLEXIBLE PAVEMENT DESIGNS WITH ALTERNATIVE MATERIALS AND THICKNESS OR RIGID PAVEMENT DESIGNS MAY BE SUBMITTED FOR CONSIDERATION AND POSSIBLE APPROVAL BY THE CITY ENGINEER.

DEVELOPMENT & ENGINEERING SERVICES DEPARTMENT  
ENGINEERING SERVICES DIVISION CITY OF SALINAS

TITLE: **STREET STRUCTURAL SECTIONS**

DESIGNED BY: STAFF

CADD BY: STAFF

PROJECT MANAGER: FRANK A. AGUAYO, P.E.

DATE: 10/21/2008

ROBERT C. RUSSELL, CITY ENGINEER  
R.C.E. 42871, EXPIRES 3-31-2010

**STANDARD PLAN**

**3**

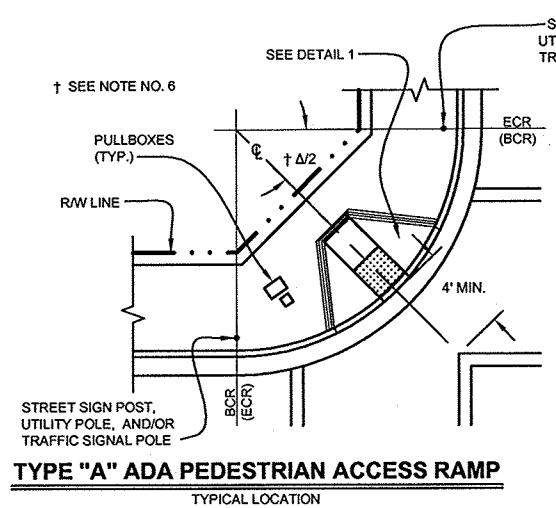

TYPE "A" ADA PEDESTRIAN ACCESS RAMP TYPICAL LOCATION

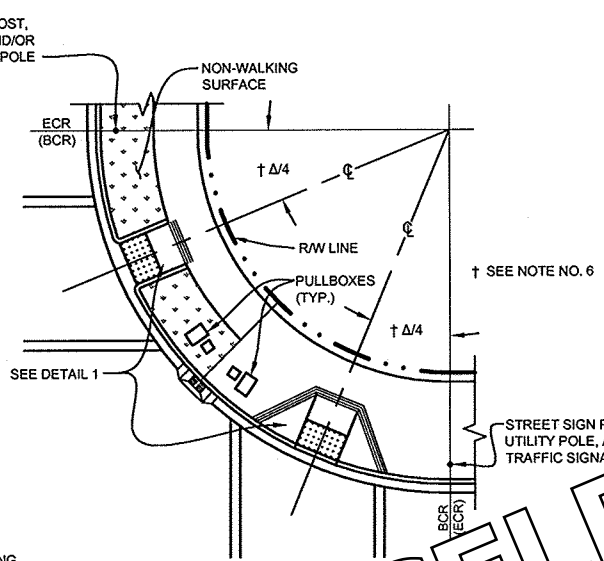

TYPE "A" ADA PEDESTRIAN ACCESS RAMP ALTERNATE LOCATION

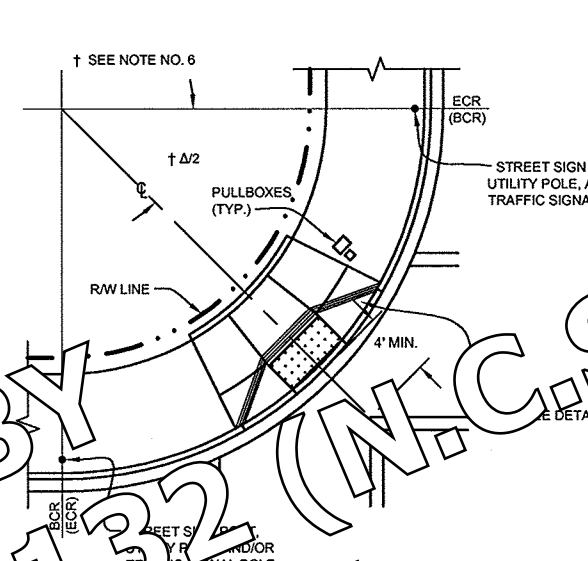

TYPE "B" ADA PEDESTRIAN ACCESS RAMP TYPICAL LOCATION

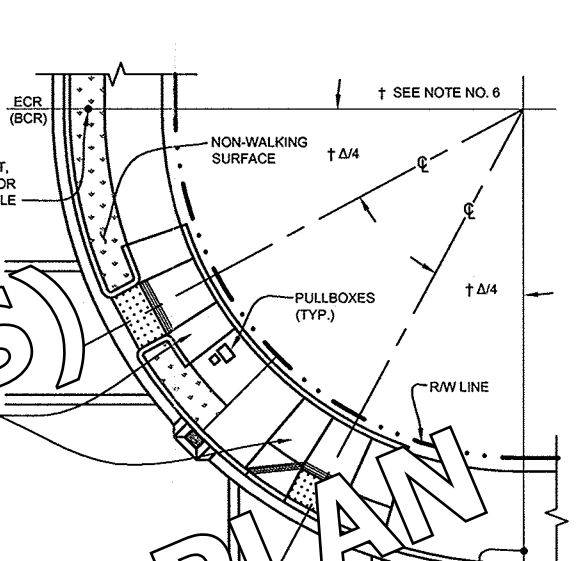

TYPE "B" ADA PEDESTRIAN ACCESS RAMP ALTERNATE LOCATION

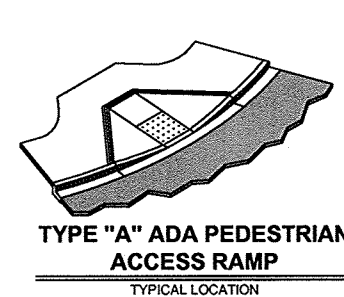
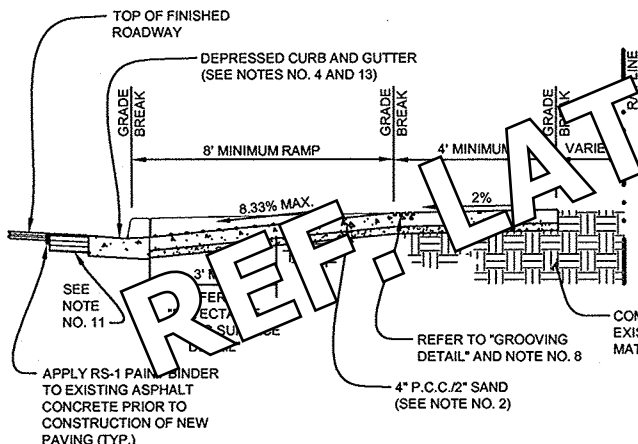
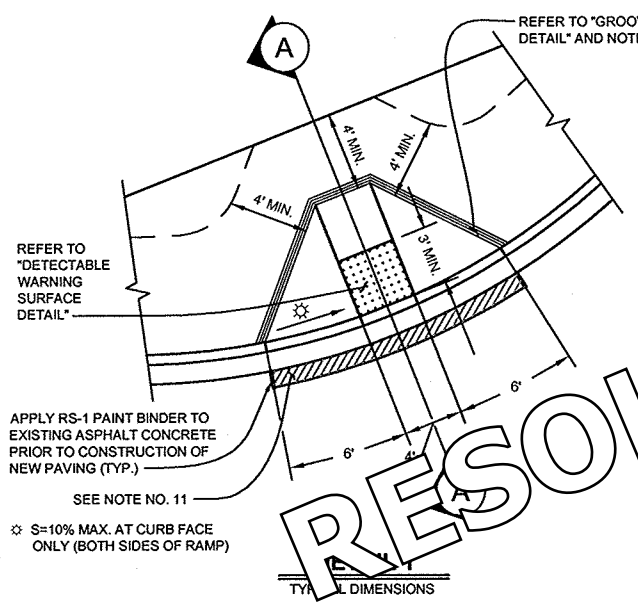

TYPE "A" ADA PEDESTRIAN ACCESS RAMP TYPICAL LOCATION

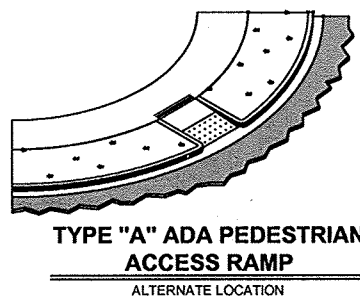

TYPE "A" ADA PEDESTRIAN ACCESS RAMP ALTERNATE LOCATION



TYPE "B" ADA PEDESTRIAN ACCESS RAMP ALTERNATE LOCATION

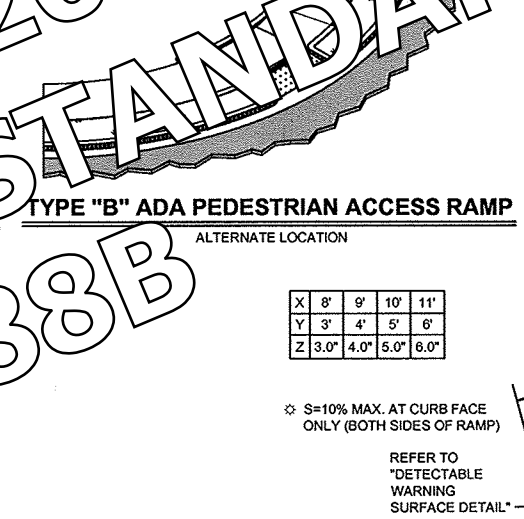

TYPE "B" ADA PEDESTRIAN ACCESS RAMP ALTERNATE LOCATION

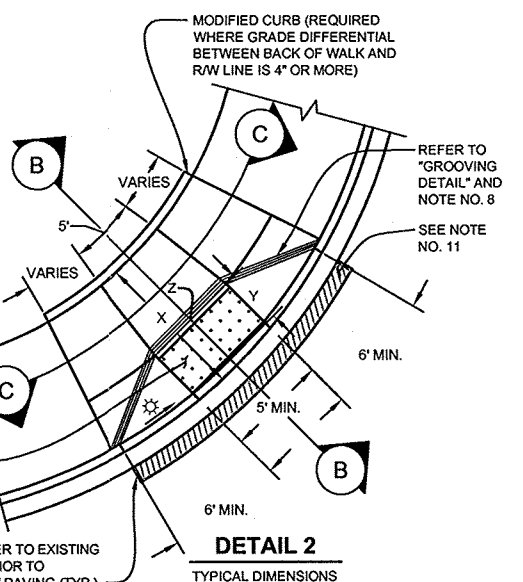

DETAIL 2 TYPICAL DIMENSIONS

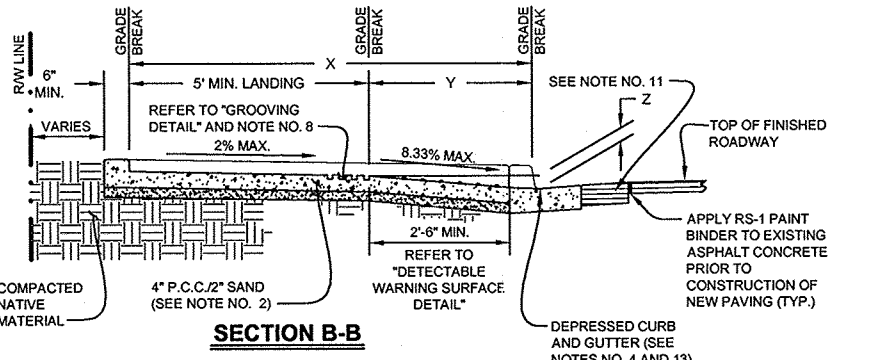

SECTION B-B

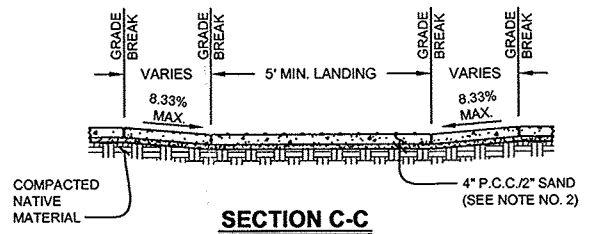

SECTION C-C

GENERAL NOTE

- DRAWING NOT TO SCALE.
- ADA COMPLIANT PEDESTRIAN ACCESS RAMP SHALL BE CLASS "3" P.C.C., 4" THICK WITH 2" SAND CUSHION, AND A COARSE BROOM FINISH.
- WIDTH OF SIDEWALK AND RADIUS OF CURB RETURN SHALL BE PER CONSTRUCTION PLANS.
- CURB AND GUTTER CONSTRUCTION SHALL BE PER CITY OF SALINAS STANDARD PLAN NO. 1.
- SIDEWALK CONSTRUCTION SHALL BE PER CITY OF SALINAS STANDARD PLAN NO. 2.
- ANY ALTERNATIVE LOCATIONS/CONFIGURATIONS ARE SUBJECT TO PRIOR APPROVAL BY THE CITY ENGINEER.
- ADA COMPLIANT PEDESTRIAN ACCESS RAMPS SHALL HAVE A DETECTABLE WARNING SURFACE THAT EXTENDS THE FULL WIDTH AND 3" MINIMUM DEPTH OF THE RAMP. THE EDGE OF THE DETECTABLE WARNING SURFACE NEAREST THE STREET SHALL BE BETWEEN 6" AND 8" FROM THE FACE OF CURB. ALL UTILITY AND CITY PULLBOXES, MANHOLES, VAULTS, AND ALL OTHER FACILITIES SHALL BE INSTALLED OUTSIDE THE DETECTABLE WARNING SURFACE BOUNDARY. THE DETECTABLE WARNING SURFACE COLOR SHALL BE YELLOW CONFORMING TO FEDERAL STANDARD 595B, COLOR NO 33538. THE DETECTABLE WARNING SURFACE SHALL BE "CAST IN PLACE" ARMOR-TILE OR APPROVED EQUAL BY THE CITY ENGINEER.
- SCORE LINES SHALL BE PROVIDED AND NOT EXCEED 22 S.F. OF CONCRETE SURFACE. SCORE LINES SHALL BE ON THE LEVEL SURFACE AT THE TOP OF THE RAMP.
- FLOW LINE SLOPE ALONG CURB RETURN SHALL BE A MINIMUM OF 0.50% OR AS APPROVED BY THE CITY ENGINEER.
- FOR CURBS HIGHER THAN 6", ADA COMPLIANT PEDESTRIAN ACCESS RAMP WING SHALL EXTEND 1' FOR EVERY 1" OF CURB HEIGHT (8.33% GRADE).
- REMOVE/REPLACE 1" AC PAVEMENT (6" THICK SECTION) ALONG GUTTER LIP FOR NEW ADA COMPLIANT PEDESTRIAN ACCESS RAMP INSTALLATION AT EXISTING CURB RETURNS.
- MODIFIED CURB SHALL BE PROVIDED AT BACK OF SIDEWALK WHERE GRADE DIFFERENTIAL BETWEEN BACK OF WALK AND RIGHT-OF-WAY LINE IS 4" OR MORE.
- COUNTER SLOPES OF ADJOINING GUTTERS AND ROAD SURFACES IMMEDIATELY ADJACENT TO THE ADA COMPLIANT PEDESTRIAN ACCESS RAMP SHALL NOT BE STEEPER THAN 5%. THE ADJACENT SURFACES AT TRANSITIONS AT ADA COMPLIANT PEDESTRIAN ACCESS RAMPS TO WALKS, GUTTERS, AND STREETS SHALL BE AT THE SAME LEVEL.
- FURNISH AND INSTALL 1/2" x 18" LONGITUDINAL REBAR CENTERED AND EPOXIED INTO NEW AND EXISTING CURB, REFER TO DETAIL "B" OF THE CITY STANDARD PLAN NO. 2.

CANCELED BY RESOLUTION NO. 21132 (N.C.S.) MARCH 7, 2017 488A & 488B

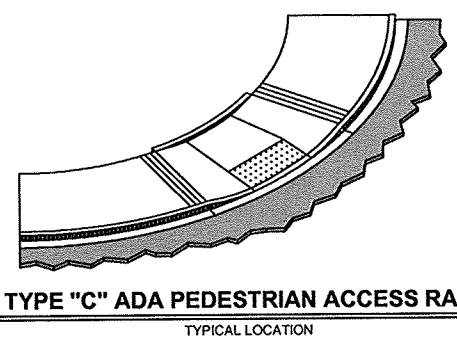
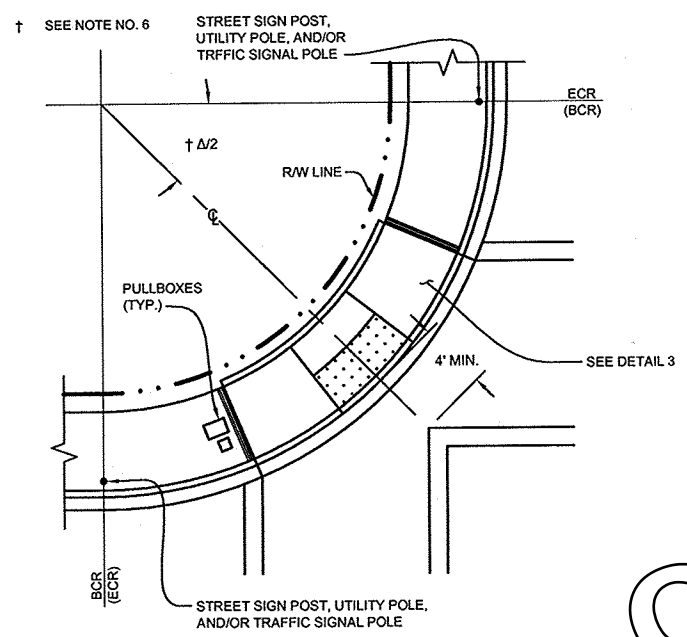

TYPE "C" ADA PEDESTRIAN ACCESS RAMP  
TYPICAL LOCATION

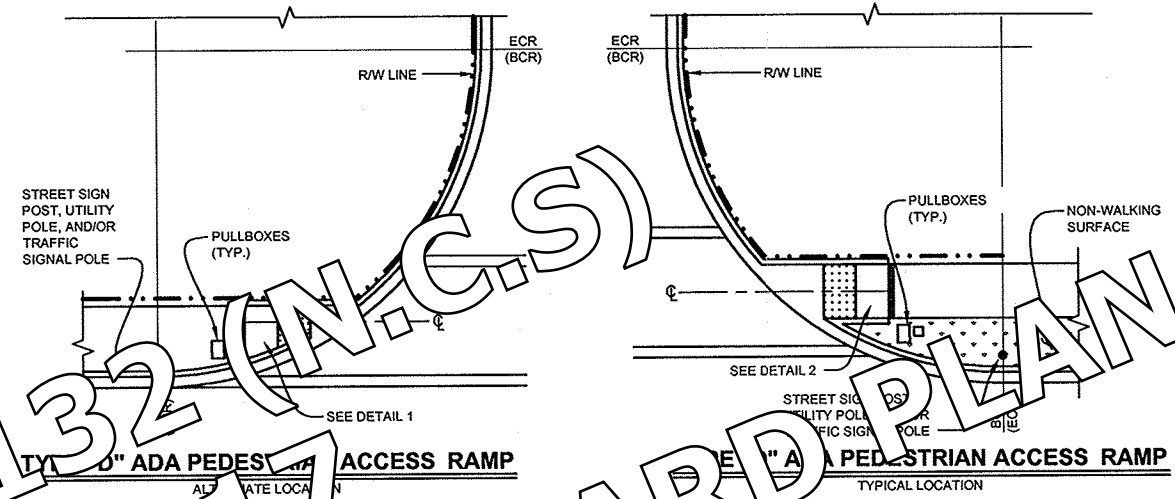

TYPE "A" ADA PEDESTRIAN ACCESS RAMP  
TYPICAL LOCATION

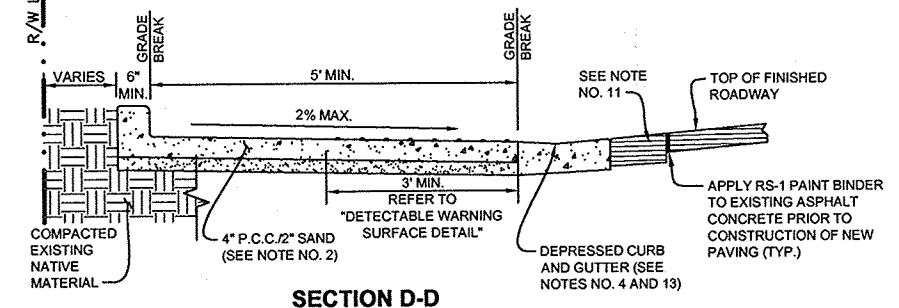
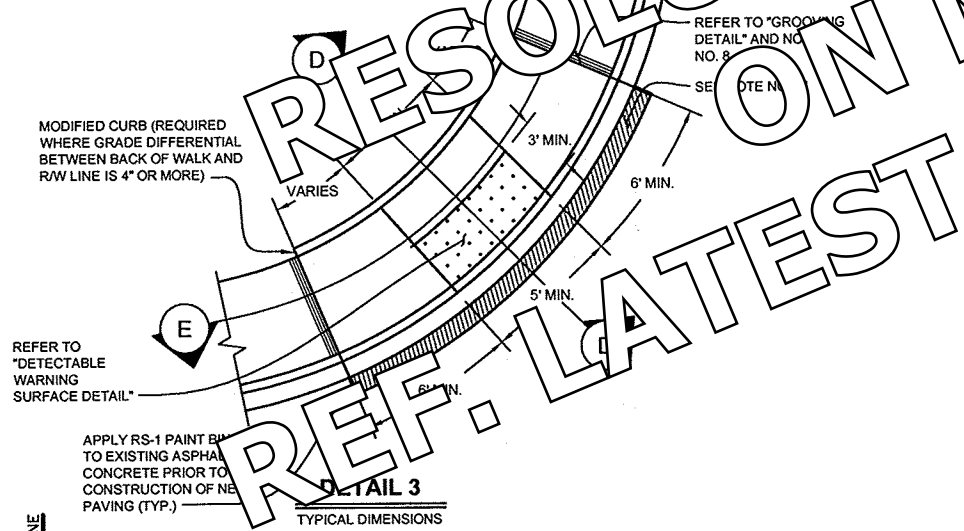

SECTION D-D

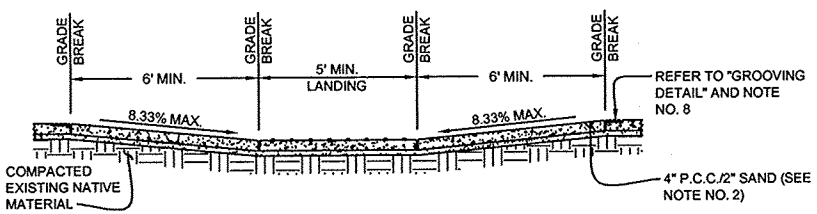

SECTION E-E

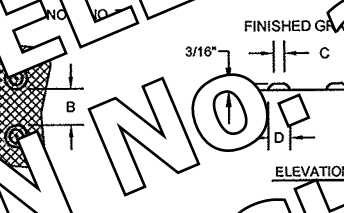

GROOVING DETAIL

DETECTABLE WARNING SURFACE DETAIL

GENERAL NOTES

- DRAWING NOT TO SCALE.
- ADA COMPLIANT PEDESTRIAN ACCESS RAMP SHALL BE CLASS "3" P.C.C., 4" THICK WITH 2" SAND CUSHION, AND A COARSE BROOM FINISH.
- WIDTH OF SIDEWALK AND RADIUS OF CURB RETURN SHALL BE PER CONSTRUCTION PLANS.
- CURB AND GUTTER CONSTRUCTION SHALL BE PER CITY OF SALINAS STANDARD PLAN NO. 1.
- SIDEWALK CONSTRUCTION SHALL BE PER CITY OF SALINAS STANDARD PLAN NO. 2.
- ANY ALTERNATIVE LOCATIONS/CONFIGURATIONS ARE SUBJECT TO PRIOR APPROVAL BY THE CITY ENGINEER.
- ADA COMPLIANT PEDESTRIAN ACCESS RAMP SHALL HAVE A DETECTABLE WARNING SURFACE THAT EXTENDS THE FULL WIDTH AND 3' MINIMUM DEPTH OF THE RAMP. THE EDGE OF THE DETECTABLE WARNING SURFACE NEAREST THE STREET SHALL BE BETWEEN 6" AND 8" FROM THE FACE OF CURB. ALL UTILITY AND CITY PULLBOXES, MANHOLES, VAULTS, AND ALL OTHER FACILITIES SHALL BE INSTALLED OUTSIDE THE DETECTABLE WARNING SURFACE BOUNDARY. THE DETECTABLE WARNING SURFACE COLOR SHALL BE YELLOW CONFORMING TO FEDERAL STANDARD 595B, COLOR NO 33538. THE DETECTABLE WARNING SURFACE SHALL BE "CAST IN PLACE" ARMOR-TILE OR APPROVED EQUAL BY THE CITY ENGINEER.
- SCORE LINES SHALL BE PROVIDED AND NOT EXCEED 22 S.F. OF CONCRETE SURFACE. SCORE LINES SHALL BE ON THE LEVEL SURFACE AT THE TOP OF THE RAMP.
- FLOW LINE SLOPE ALONG CURB RETURN SHALL BE A MINIMUM OF 0.50% OR AS APPROVED BY THE CITY ENGINEER.
- FOR CURBS HIGHER THAN 6", ADA COMPLIANT PEDESTRIAN ACCESS RAMP WING SHALL EXTEND 1' FOR EVERY 1" OF CURB HEIGHT (8.33% GRADE).
- REMOVE/REPLACE 1" AC PAVEMENT (6" THICK SECTION) ALONG GUTTER LIP FOR NEW ADA COMPLIANT PEDESTRIAN ACCESS RAMP INSTALLATION AT EXISTING CURB RETURNS.
- MODIFIED CURB SHALL BE PROVIDED AT BACK OF SIDEWALK WHERE GRADE DIFFERENTIAL BETWEEN BACK OF WALK AND RIGHT-OF-WAY LINE IS 4" OR MORE.
- COUNTER SLOPES OF ADJOINING GUTTERS AND ROAD SURFACES IMMEDIATELY ADJACENT TO THE ADA COMPLIANT PEDESTRIAN ACCESS RAMP SHALL NOT BE STEEPER THAN 5%. THE ADJACENT SURFACES AT TRANSITIONS AT ADA COMPLIANT PEDESTRIAN ACCESS RAMP TO WALKS, GUTTERS, AND STREETS SHALL BE AT THE SAME LEVEL.
- FURNISH AND INSTALL 1/2" x 18" LONGITUDINAL REBAR CENTERED AND EPOXIED INTO NEW AND EXISTING CURB, REFER TO DETAIL "B" OF THE CITY STANDARD PLAN NO. 2.

CANCELED BY RESOLUTION NO. 21132 (N.G.S) ON MARCH 7, 2017 CALTRANS STANDARD PLAN 488A & 488B REF. LATEST



## RESIDENTIAL DRIVEWAY APPROACH

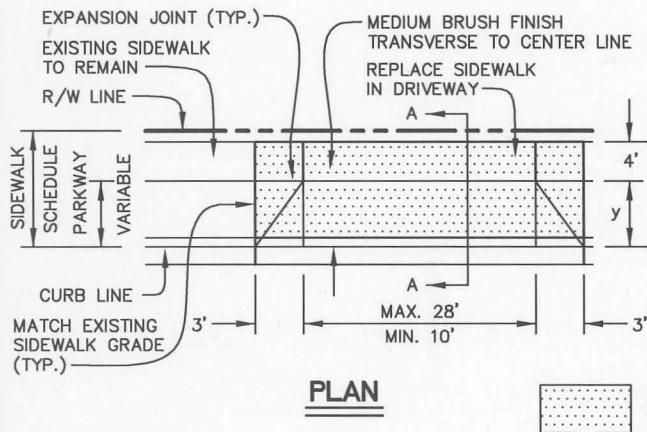

## COMMERCIAL DRIVEWAY APPROACH

OPTION: 4' SIDEWALK MAY BE BEHIND PROPERTY LINE

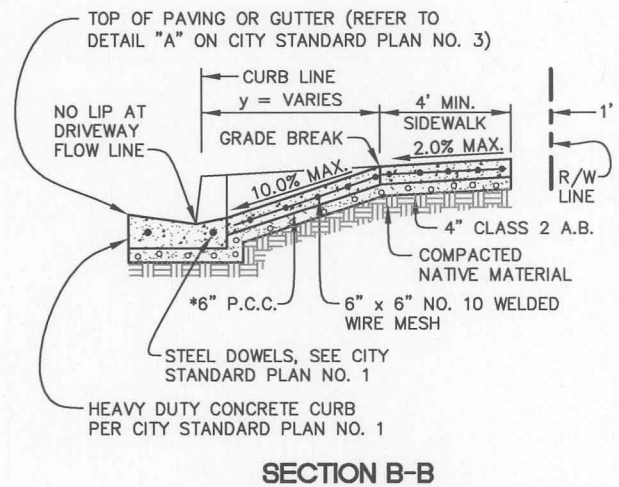
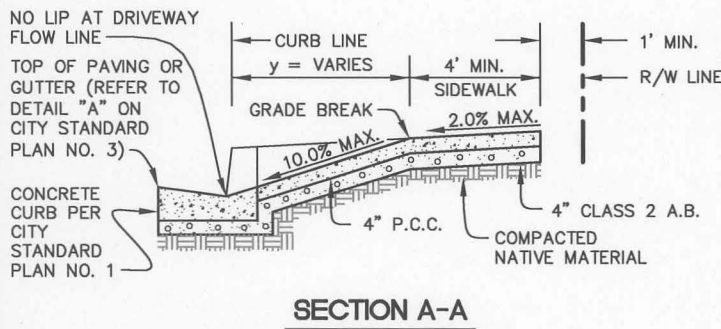
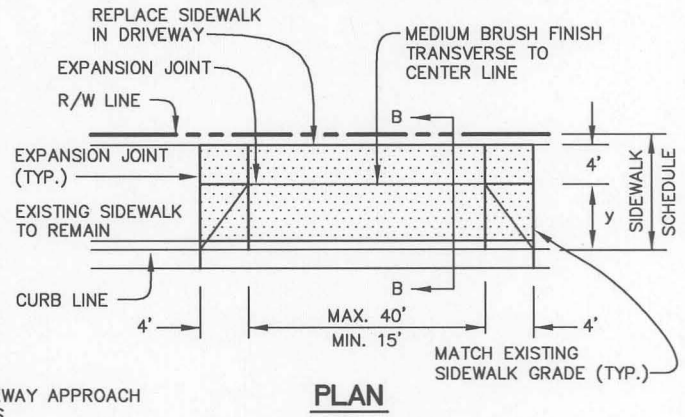

### GENERAL NOTES

- DRAWING NOT TO SCALE.
- ALL WORK SHALL BE CONSTRUCTED IN ACCORDANCE WITH THE LATEST ADOPTED CITY STANDARD SPECIFICATIONS.
- THE AREA INCLUDED WITHIN THE "y" SLOPES SHALL BE MEDIUM BRUSH FINISH. THE BALANCE OF THE DRIVEWAY SHALL BE FINE BROOM FINISH TO MATCH THE ADJOINING SIDEWALK. SCORING LINES SHALL BE SPACED TO EVENLY DIVIDE THE AREA INTO BLOCKS OF NOT LESS THAN 3' AND NOT MORE THAN 4' OR MATCH EXISTING.
- RESIDENTIAL DRIVEWAYS SHALL HAVE 4" MINIMUM CLASS 4 A.B. (OR BETTER). COMMERCIAL DRIVEWAYS SHALL HAVE 4" MINIMUM CLASS 2 A.B. AND 6" x 6" NO. 10 WELDED WIRE MESH PLACED AT MID-DEPTH OF CONCRETE.
- CONCRETE SHALL BE CLASS "3" PER CITY STANDARD SPECIFICATIONS.
- ON RESIDENTIAL DRIVEWAY CONSTRUCTION ONLY, CONTRACTOR MAY REMOVE VERTICAL CURB AND CONSTRUCT DRIVEWAY AGAINST REMAINING GUTTER. CITY ENGINEER APPROVED BONDING AGENT OR EPOXY SHALL BE APPLIED TO JOIN CONCRETE SURFACES.
- CURB HEIGHT HIGHER THAN 6 1/2" SHALL BE APPROVED BY THE CITY ENGINEER PRIOR TO CONSTRUCTION.
- \* INCREASE CONCRETE THICKNESS BY 2" FOR DRIVEWAYS SERVING INDUSTRIAL SITES WHICH ARE SUBJECT TO HEAVY TRUCK TRAFFIC.
- ALL DRIVEWAYS SHALL INCLUDE SIDEWALKS THAT ARE ADA COMPLIANT.

## DEVELOPMENT & ENGINEERING SERVICES DEPARTMENT

ENGINEERING SERVICES DIVISION

CITY OF SALINAS

TITLE: **DRIVEWAY APPROACH**

STANDARD PLAN

DESIGNED BY:  
STAFF

DATE 10/21/2008

CADD BY:  
STAFF

PROJECT MANAGER:  
FRANK A. AGUAYO, P.E.

ROBERT C. RUSSELL, CITY ENGINEER  
R.C.E. 42871, EXPIRES 3-31-2010



**5**

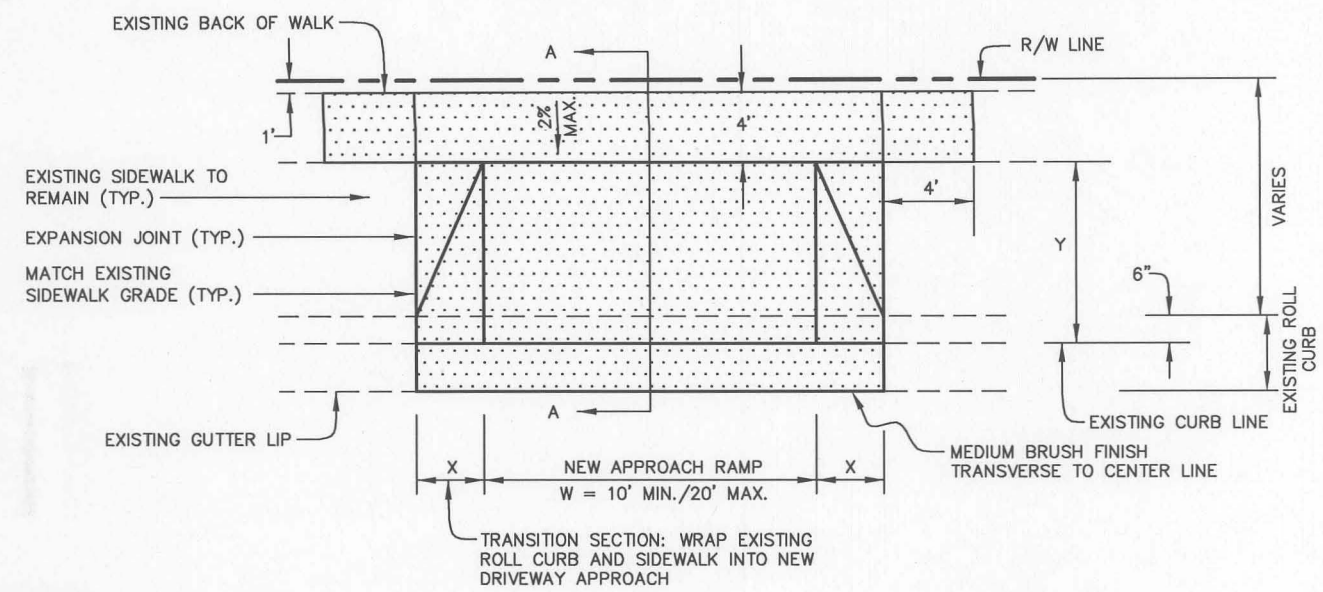

 DRIVEWAY APPROACH LIMITS

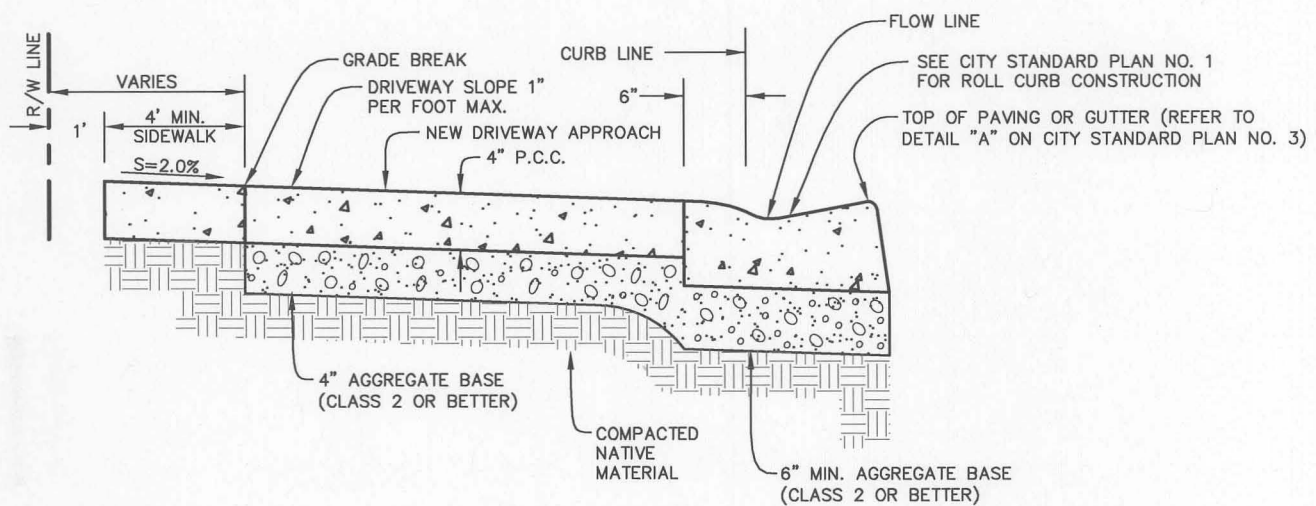

**PLAN**



**SECTION A-A**

**GENERAL NOTES**

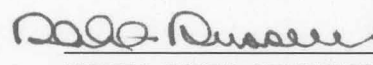
1. DRAWING NOT TO SCALE.
2. "Y" SHALL EXTEND TO THE FRONT EDGE OF THE SIDEWALK BUT SHALL NOT BE LESS THAN 4' UNLESS OTHERWISE SPECIFIED AND APPROVED BY THE CITY ENGINEER.
3. CONCRETE SHALL BE CLASS "3" PER CITY STANDARD SPECIFICATIONS.
4. THE AREA INCLUDED WITHIN THE "Y" SLOPES SHALL BE MEDIUM BRUSH FINISH. THE BALANCE OF THE DRIVEWAY SHALL BE FINE BROOM FINISH TO MATCH THE ADJOINING SIDEWALK. SCORING LINES SHALL BE SPACED TO EVENLY DIVIDE THE AREA INTO BLOCKS OF NOT LESS THAN 3' AND NOT MORE THAN 4' OR MATCH EXISTING.
5. ALL WORK SHALL BE CONSTRUCTED IN ACCORDANCE WITH THE LATEST ADOPTED CITY STANDARD SPECIFICATIONS.

<b>DEVELOPMENT &amp; ENGINEERING SERVICES DEPARTMENT</b>		CITY OF SALINAS
ENGINEERING SERVICES DIVISION		
<b>TITLE: DRIVEWAY APPROACH FOR ROLL TYPE CURB</b>		<b>STANDARD PLAN</b>
DESIGNED BY: STAFF	DATE 10/21/2008	<b>6</b>
CADD BY: STAFF		
PROJECT MANAGER: FRANK A. AGUAYO, P.E.	ROBERT C. RUSSELL, CITY ENGINEER R.C.E. 42871, EXPIRES 3-31-2010	
		

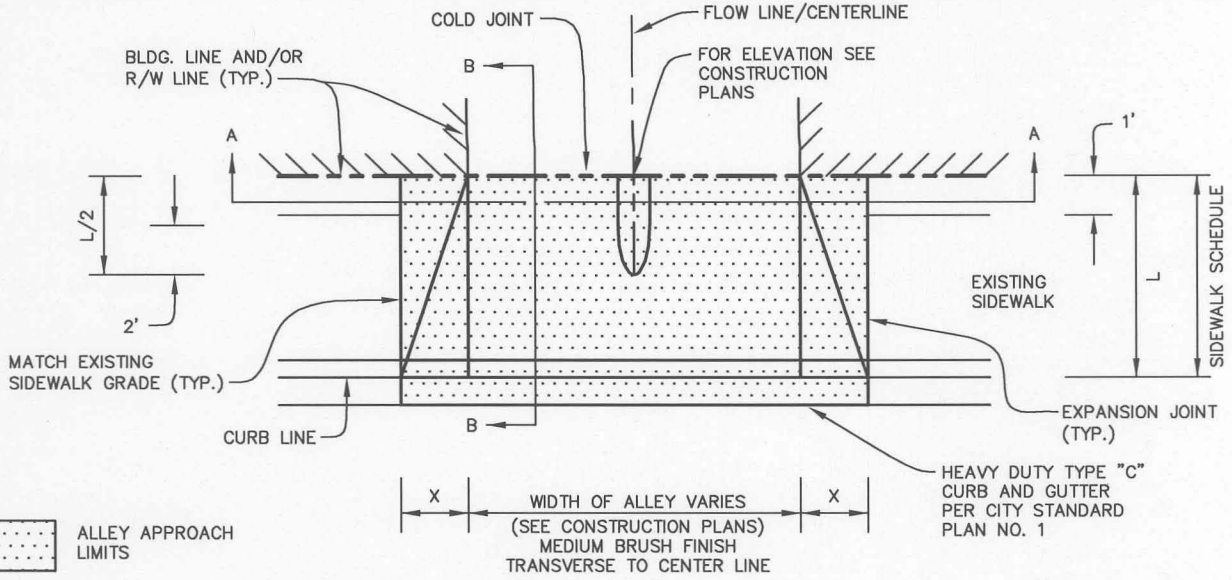

**PLAN**

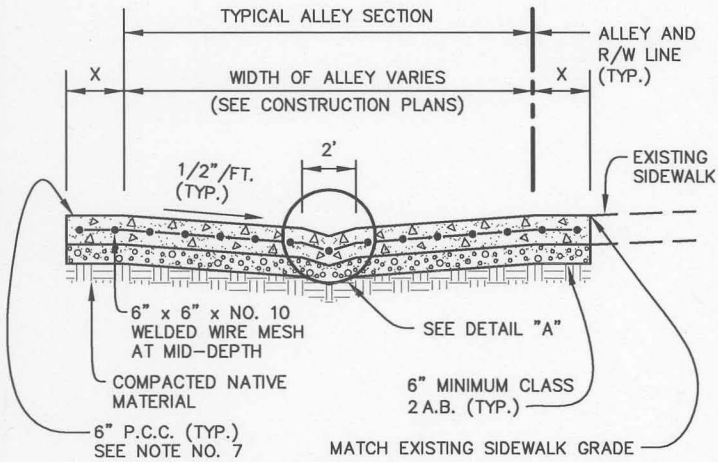

**SECTION A-A**

(ALLEY APPROACH AND ALLEY)

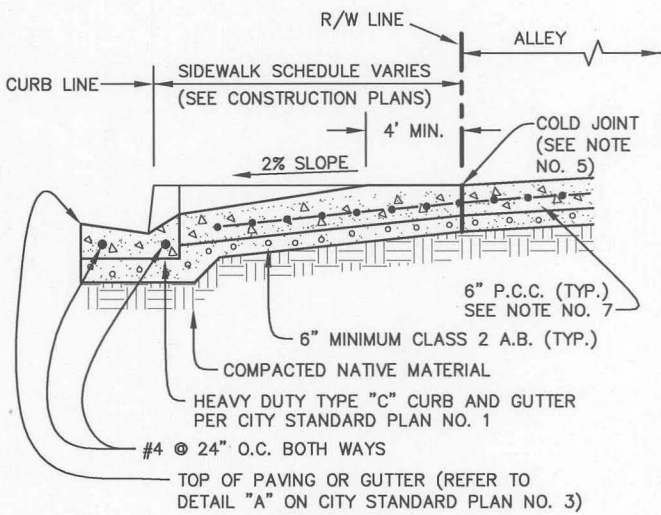

**SECTION B-B**

**GENERAL NOTES**

1. DRAWING NOT TO SCALE.
2. ALL WORK AND MATERIALS SHALL CONFORM TO SECTION 73 OF THE CITY STANDARD SPECIFICATIONS "DRIVEWAY CONSTRUCTION".
3. SEE CITY STANDARD PLAN NO. 1 FOR CURB AND GUTTER CONSTRUCTION.
4. THE "X" DIMENSION SHALL BE 3' UNLESS OTHERWISE INDICATED ON PLANS.
5. PROVIDE COLD JOINT AT BACK OF ALLEY APPROACH (OMIT STEEL ACROSS THIS JOINT).
6. ALL CONCRETE SHALL BE CLASS "3" PER CITY STANDARD SPECIFICATIONS.
7. INCREASE CONCRETE THICKNESS BY 2" FOR DRIVEWAYS SERVING INDUSTRIAL SITES OR SITES SUBJECT TO HEAVY TRUCK TRAFFIC.

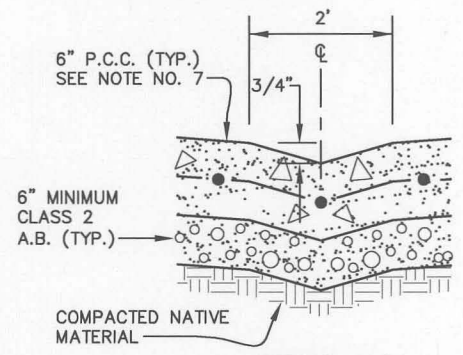

**DETAIL 'A'**

**DEVELOPMENT & ENGINEERING SERVICES DEPARTMENT**  
 ENGINEERING SERVICES DIVISION CITY OF SALINAS

<b>TITLE: ALLEY APPROACH AND SECTION</b>	
DESIGNED BY: STAFF	DATE <u>10/21/2008</u>
CADD BY: STAFF	<i>Robert C. Russell</i>
PROJECT MANAGER: FRANK A. AGUAYO, P.E.	ROBERT C. RUSSELL, CITY ENGINEER R.C.E. 42871, EXPIRES 3-31-2010

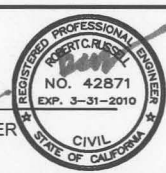

**STANDARD PLAN**

7

EXISTING STRUCTURAL SECTION OR AS SPECIFIED ON PLANS  
FINISHED GRADE

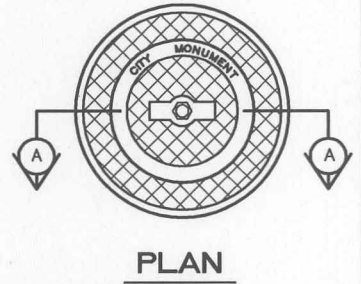
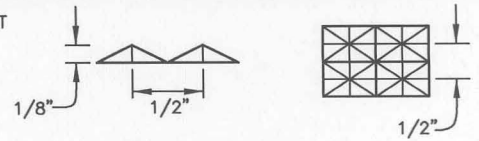
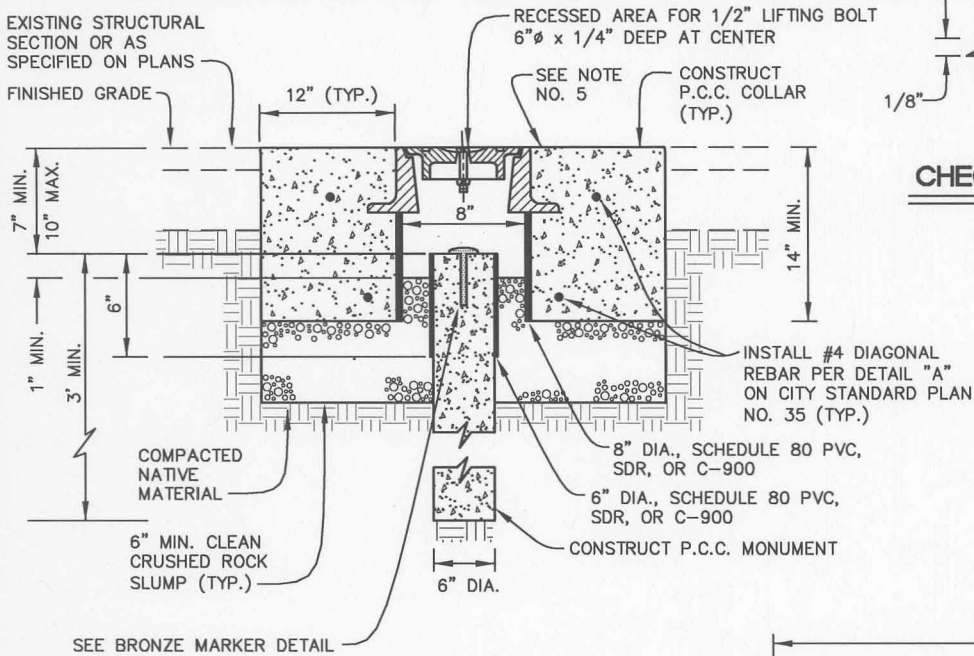

**SECTION A-A**

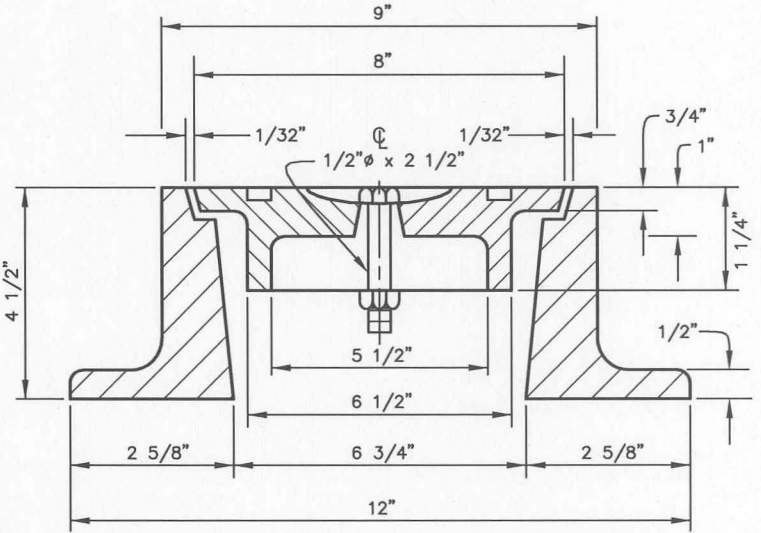

**FRAME AND COVER SECTION**

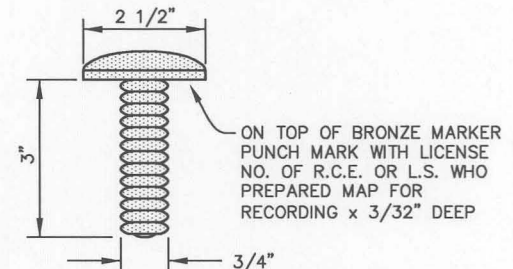

**BRONZE MARKER DETAIL**

**GENERAL NOTES**

1. DRAWING NOT TO SCALE.
2. MONUMENT FRAME AND COVER SHALL BE GRAY CAST IRON, FREE OF BLISTERS, BLOWHOLES, AND COLD SHUNTS.
3. MONUMENT SHALL BE FURNISHED AND INSTALLED PER PLANS AND SECTION 81 OF THE CITY STANDARD SPECIFICATIONS, COMPLETE WITH MARKER. CONTRACTOR SHALL PROVIDE BRONZE MARKER.
4. BEARING SURFACES OF FRAME AND COVER SHALL FIT WITH POSITIVE PRESSURE ON ALL SURFACES AND SHALL BE NON-ROCKING.
5. ALL CONCRETE SHALL BE CONSTRUCTED IN ACCORDANCE WITH CLASS "3" OF THE CITY STANDARD SPECIFICATIONS. MIX CONCRETE WITH BLACK PIGMENT MATERIAL.
6. FRAME AND COVER SHALL BE AMERICAN BRASS AND FOUNDRY 5020-21 OR APPROVED EQUAL BY THE CITY ENGINEER.
7. CONTRACTOR SHALL PROVIDE SURVEY OF CENTERLINE CONTROL AND FINAL PUNCH MARK WITH R.C.E. OR L.S. REGISTRATION NUMBER PER BRONZE MARKER DETAIL.
8. MONUMENTS SHALL BE PROPERLY DOCUMENTED IN THE PUBLIC RECORDS IN ACCORDANCE WITH THE REQUIREMENTS OF THE "BUSINESS AND PROFESSIONAL CODE" OF THE STATE OF CALIFORNIA CHAPTER 15, "LAND SURVEYORS" ARTICLE 5, "SURVEYING PRACTICE," AND SECTION 8762, "RECORD OF SURVEY" WHEN REQUIRED.

**DEVELOPMENT & ENGINEERING SERVICES DEPARTMENT**

ENGINEERING SERVICES DIVISION

CITY OF SALINAS

TITLE: **CITY MONUMENT**

**STANDARD PLAN**

DESIGNED BY:  
STAFF  
CADD BY:  
STAFF  
PROJECT MANAGER:  
FRANK A. AGUAYO, P.E.

DATE 10/21/2008

*Robert C. Russell*

ROBERT C. RUSSELL, CITY ENGINEER  
R.C.E. 42871, EXPIRES 3-31-2010

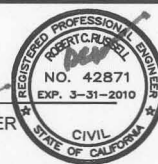

**8**



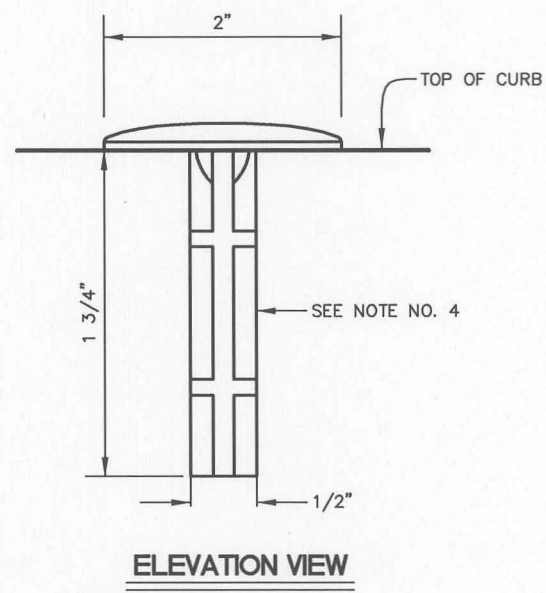
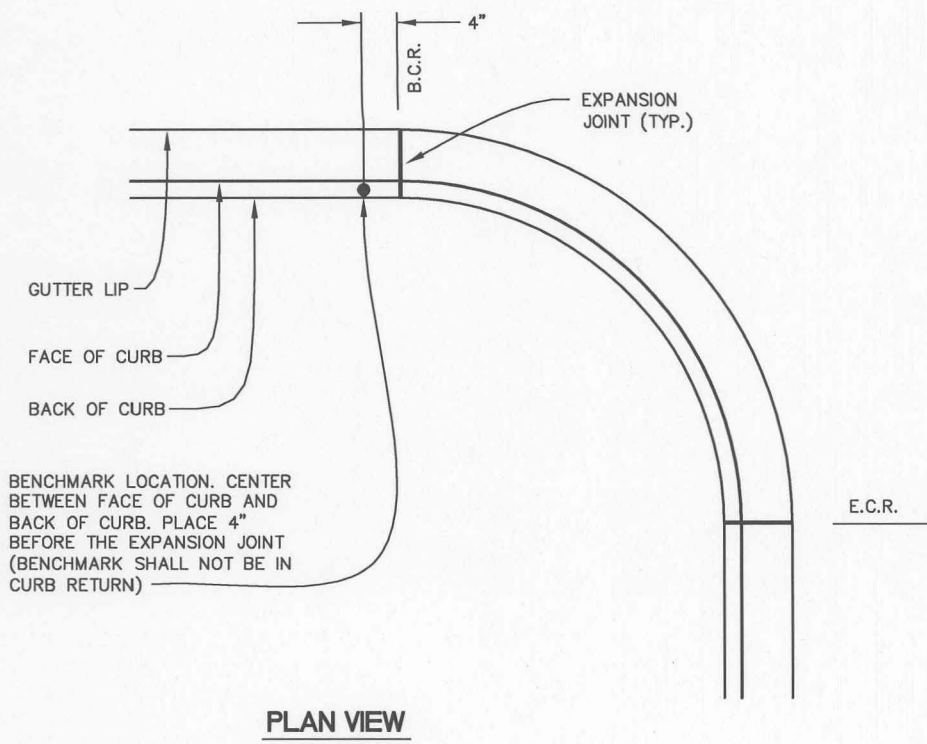

**GENERAL NOTES**

1. DRAWING NOT TO SCALE.
2. CONTRACTOR SHALL BE RESPONSIBLE FOR RE-ESTABLISHING AND SETTING THE NEW CITY BENCHMARK.
3. BENCHMARK LOCATION SHALL BE CENTERED AT THE TOP OF CURB AND 4" BEFORE THE EXPANSION JOINT. THE CITY ENGINEER SHALL APPROVE EXACT LOCATION PRIOR TO INSTALLATION.
4. BENCHMARK SHALL BE A 2" DIAMETER SOLID BRASS DOMED SURVEY MARKER. BENCHMARK SHALL BE INSTALLED AT THE TIME OF CONSTRUCTION AND SHALL BE WET SET.
5. VERTICAL ELEVATION, WHICH SHALL BE DERIVED FROM A KNOWN VICINITY BENCHMARK, SHALL BE ESTABLISHED BY A CONTRACTOR HIRED REGISTERED CIVIL ENGINEER OR PROFESSIONAL LAND SURVEYOR. THE NEW BENCHMARK SHALL THEN BE VERIFIED BY THE CONTRACTOR'S SURVEYOR BY USING ANOTHER KNOWN CITY BENCHMARK AS A DOUBLE CHECK. THE HIRED REGISTERED C.E. OR P.L.S. SHALL PUNCH MARK THE DOMED MARKER WITH THE NEW VERTICAL ELEVATION. THE CONTRACTOR SHALL THEN PROVIDE IN WRITING TO THE CITY ENGINEER THE NEW VERTICAL ELEVATION WITHIN TWO DAYS OF THE BENCHMARK INSTALLATION.

**DEVELOPMENT & ENGINEERING SERVICES DEPARTMENT**

ENGINEERING SERVICES DIVISION CITY OF SALINAS

TITLE: **BENCHMARK FOR ELEVATION CONTROL**

**STANDARD PLAN**

**9**

DESIGNED BY:  
STAFF

CADD BY:  
STAFF

PROJECT MANAGER:  
FRANK A. AGUAYO, P.E.

DATE 10/21/2008

*Robert C. Russell*

ROBERT C. RUSSELL, CITY ENGINEER  
R.C.E. 42871, EXPIRES 3-31-2010



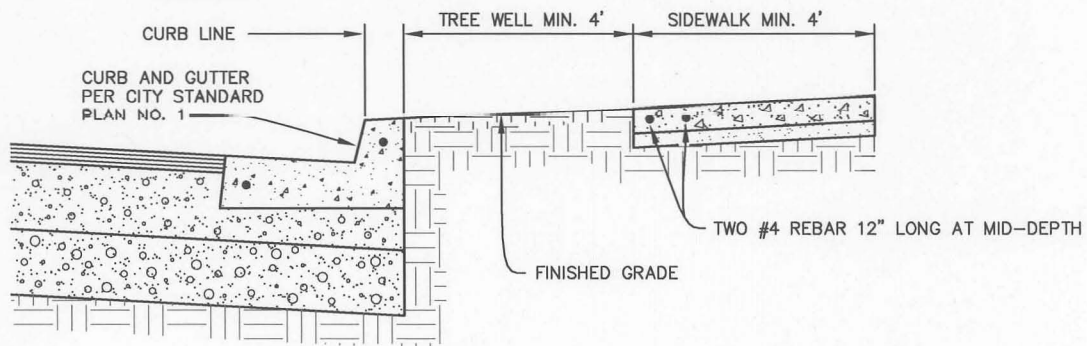
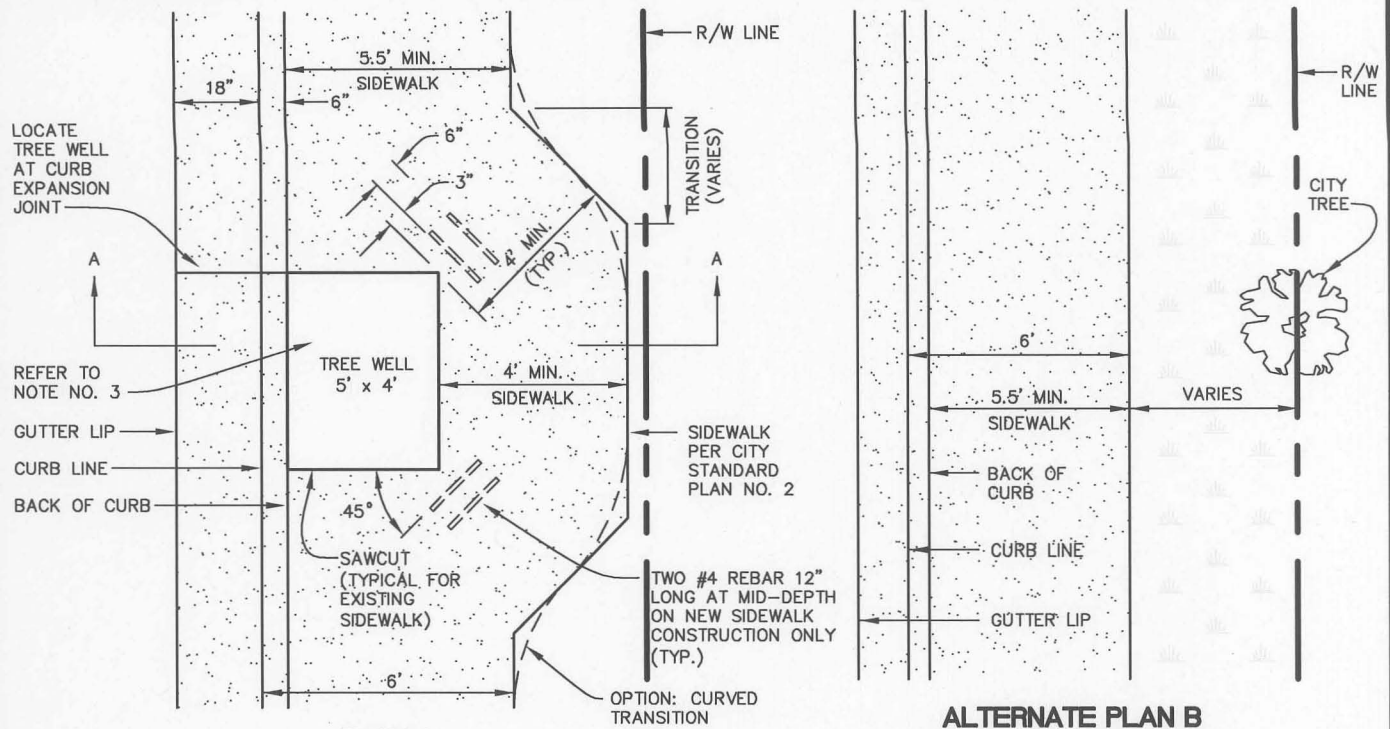

**GENERAL NOTES**

1. DRAWING NOT TO SCALE.
2. FOR STREET TREE PLANTING SEE CITY STANDARD PLAN NO. 11.
3. TREE WELL SHALL BE 5' x 4' MINIMUM RECTANGLE.
4. UNLESS OTHERWISE SPECIFIED IN THE SPECIFICATIONS AND/OR PLANS ALL PLACEMENT OF TREE WELL LOCATIONS SHALL BE AS FOLLOWS:
  - a. MINIMUM OF 40' FROM THE POINT OF INTERSECTION OF CURB LINE (P.I.).
  - b. MINIMUM OF 40' FROM THE TRAFFIC SIGNAL POLES.
  - c. MINIMUM OF 15' FROM COMMERCIAL DRIVEWAYS AND 10' FROM RESIDENTIAL DRIVEWAYS.
  - d. MINIMUM OF 25' FROM CATCH BASINS, SANITARY SEWER MAINS AND LATERALS, AND MANHOLES.
  - e. MINIMUM OF 5' FROM WATER METERS, WATER LINES, GAS LINES, STORM DRAIN LINES, AND UNDERGROUND ELECTRICAL LINES.
  - f. MINIMUM OF 10' FROM FIRE HYDRANTS.
  - g. MINIMUM OF 20' FROM STREET LIGHT POLES.
  - h. MINIMUM OF 10' FROM UTILITY POLES.
  - i. MINIMUM OF 40' TO 80' OF SPACING BETWEEN TREES (AVERAGE SPACING IS 60' APART) OR ONE TREE PER LOT. SPECIES OF TREE AND SPACING SHALL BE DETERMINED BY CITY ENGINEER.

**DEVELOPMENT & ENGINEERING SERVICES DEPARTMENT**  
 ENGINEERING SERVICES DIVISION CITY OF SALINAS

TITLE: <b>TREE WELL</b>		<b>STANDARD PLAN</b>
DESIGNED BY: STAFF	DATE <u>10/21/2008</u>	<b>10</b>
CADD BY: STAFF	<i>Robert Russell</i>	
PROJECT MANAGER: FRANK A. AGUAYO, P.E.	ROBERT C. RUSSELL, CITY ENGINEER R.C.E. 42871, EXPIRES 3-31-2010	

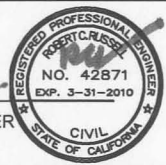

2 EACH—2" x 10' (MIN.) LODGE POLE PINE TREE STAKES. PEELER CORE STAKES NOT ACCEPTABLE. DO NOT PUT STAKE THROUGH ROOTBALL (TYP.)

15 GALLON TREE PER CITY STREET TREE SCHEDULE

1/2" THICKNESS OF DECOMPOSED GRANITE SLOPED TOWARD TREE AT TREE WELLS

CURB LINE

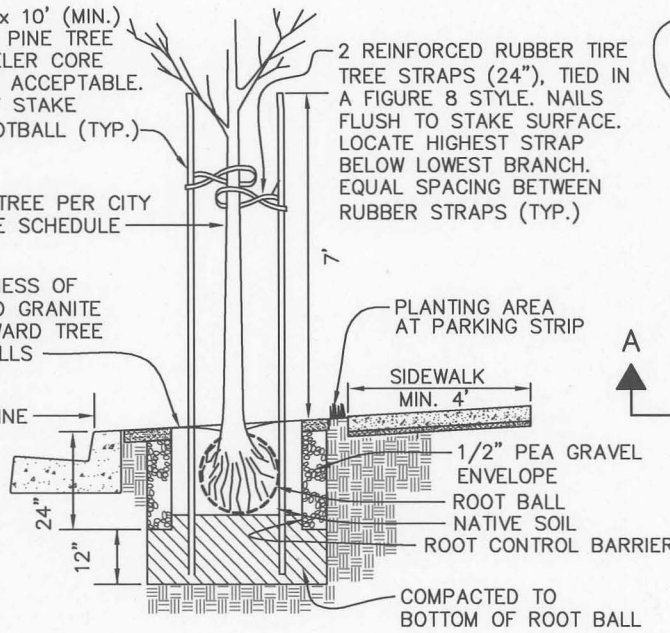

**STAKING DETAIL**

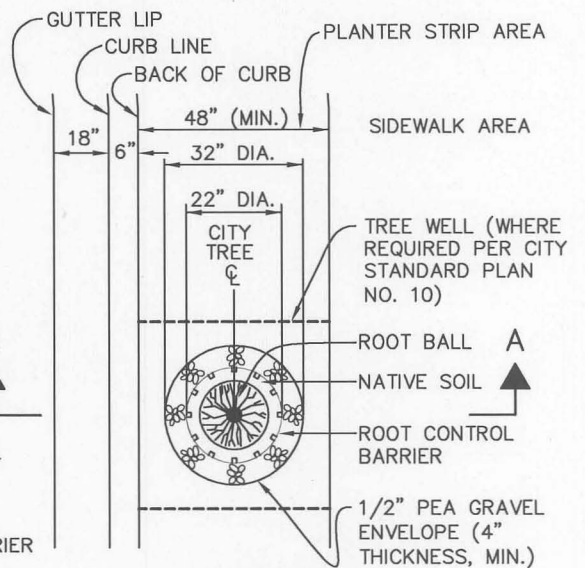

**PLAN VIEW**

**GENERAL NOTES**

- DRAWING NOT TO SCALE.
- ALL STREET TREES SHALL BE 15 GALLON AND MEET THE AMERICAN STANDARD FOR NURSERY, OR AS DIRECTED BY THE CITY ENGINEER. TREE SHOULD STAND UPRIGHT W/OUT STAKES.
- ROOT CONTROL BARRIERS SHALL BE "SHAWTOWN" NO. FI-15, THE "DEEP ROOT" NO. UB 24-2 (OR APPROVED EQUAL BY THE CITY ENGINEER). THE ONE PIECE BARRIER SHALL HAVE TAPERED SIDES AND BE CONSTRUCTED OF .085" MINIMUM THICKNESS HIGH IMPACT POLYPROPYLENE PLASTIC (HIPP) WITH ADDED ULTRAVIOLET INHIBITORS.
- THE LOWER 12" OF THE EXCAVATION SHALL BE BACKFILLED AND COMPACTED WITH NATIVE SOIL. PRIOR TO PLACING THE ROOT CONTROL BARRIER, BACKFILL 1/2" PEA GRAVEL ENVELOPE AROUND DEFLECTOR AFTER TREE PLANTING.
- NATIVE SOIL SHALL BE PLACED IN THE PLANTING HOLE AND COMPACTED TO THE BOTTOM OF THE ROOT BALL ELEVATION. PLANT TREE IN PLANTER, BACKFILL WITH NATIVE SOIL, AND COMPACT.
- AFTER PLANTING, TREE SHALL BE WATERED WITH 20 GALLONS OF WATER. REPEAT WATERING TWICE IN THE NEXT 7 DAYS, AT 48 HOUR INTERVALS.

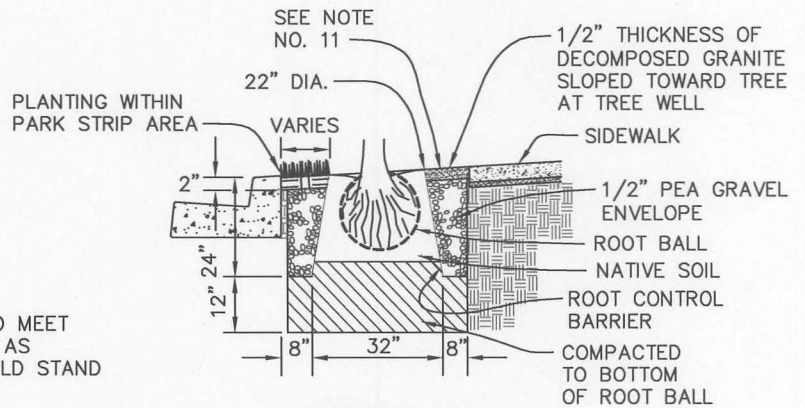

**SECTION A-A**

- CITY STREET TREE PLANTING SHALL INCLUDE TREE PLANTING IN TREE WELLS OR WITHIN PARKING STRIPS.
- UPON APPROVAL OF THE CITY ENGINEER, THE ROOT CONTROL BARRIER MAY BE DELETED DUE TO SPECIAL CIRCUMSTANCES WHICH MAKE THE ROOT CONTROL BARRIER UNUSABLE OR UNNECESSARY.
- PLANTING SPACING 40'-60'. SEE CITY STANDARD PLAN NO. 10 FOR CLEARANCE STANDARDS.
- \*LOMBARDY POPLAR TREES ARE NOT PERMITTED IN THE CITY OF SALINAS (PER CA. CODE OF REGULATIONS § 3597).
- INSTALL 4" IRRIGATION TUBE ON BOTH SIDES OF TREE IN THE SLOPED DECOMPOSED GRANITE AREA. IRRIGATION TUBE SHALL REACH A DEPTH EQUAL TO THE BOTTOM OF TREE ROOT BALL.

**DEVELOPMENT & ENGINEERING SERVICES DEPARTMENT**

ENGINEERING SERVICES DIVISION

CITY OF SALINAS

TITLE: **STREET TREE PLANTING**

**STANDARD PLAN**

DESIGNED BY:  
STAFF

DATE 10/21/2008

CADD BY:  
STAFF

*Robert C. Russell*

PROJECT MANAGER:  
FRANK A. AGUAYO, P.E.

ROBERT C. RUSSELL, CITY ENGINEER  
R.C.E. 42871, EXPIRES 3-31-2010



REVIEWED BY:

DATE:

*[Signature]* 12-16-08

MAINTENANCE  
SERVICES  
DIRECTOR

**11**



PLANTER OFFSET DISTANCE	
A	7'-0"
B	10'-6"
C	11'-6"
D	12'-0"

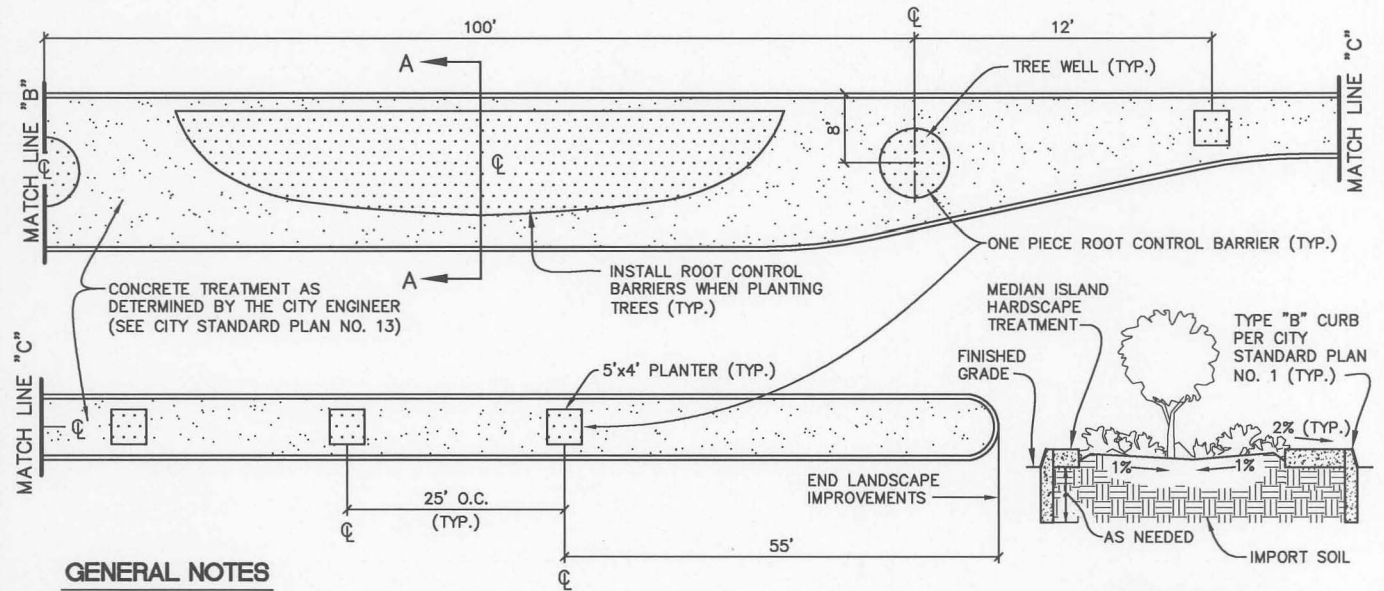
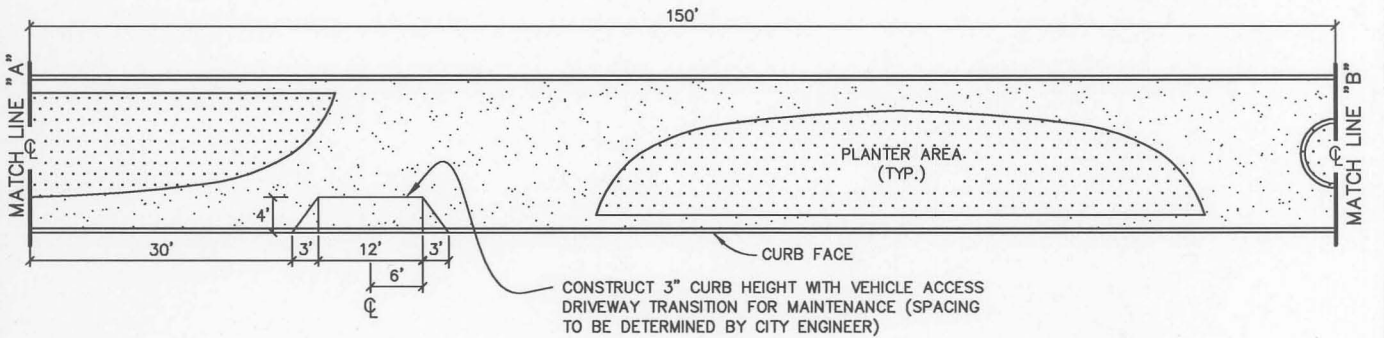
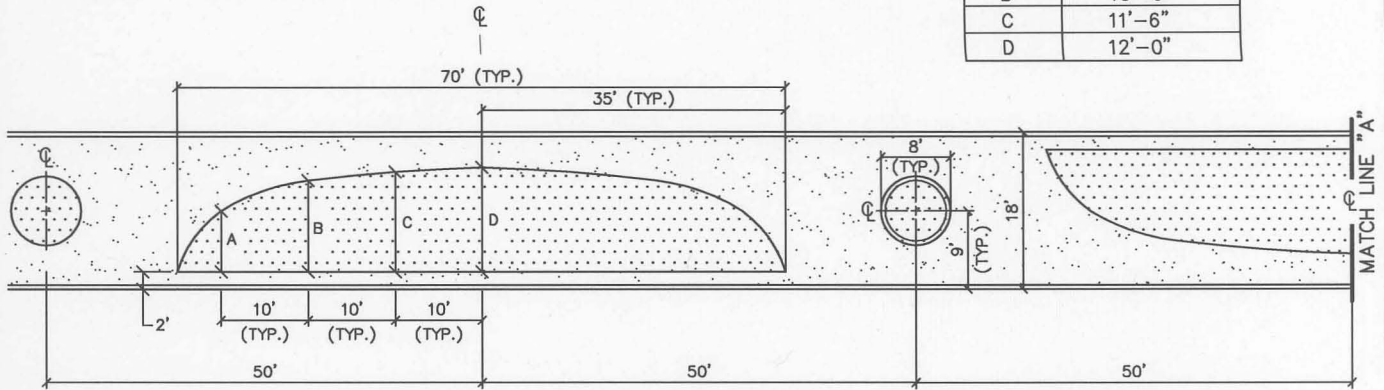

**GENERAL NOTES**

1. DRAWING NOT TO SCALE.
2. SEE CITY STANDARD PLAN NO. 11 FOR TYPE AND INSTALLATION OF ROOT CONTROL BARRIER.
3. SEE CITY STANDARD PLAN NO. 13 FOR RAISED MEDIAN ISLAND STANDARD PLANTING PLAN.

**SECTION A-A**

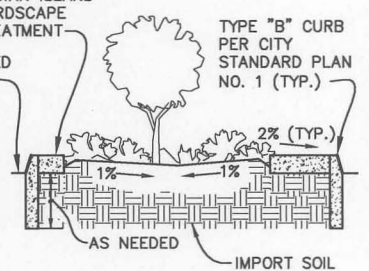

**DEVELOPMENT & ENGINEERING SERVICES DEPARTMENT**  
ENGINEERING SERVICES DIVISION CITY OF SALINAS

**TITLE: RAISED MEDIAN ISLAND STANDARD CONSTRUCTION PLAN**

**STANDARD PLAN**  
  
**12**

DESIGNED BY:  
STAFF

CADD BY:  
STAFF

PROJECT MANAGER:  
FRANK A. AGUAYO, P.E.

DATE 10/21/2008

*Robert C. Russell*

ROBERT C. RUSSELL, CITY ENGINEER  
R.C.E. 42871, EXPIRES 3-31-2010

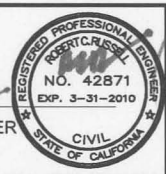

REVIEWED BY:  
*[Signature]*

MAINTENANCE SERVICES DIRECTOR



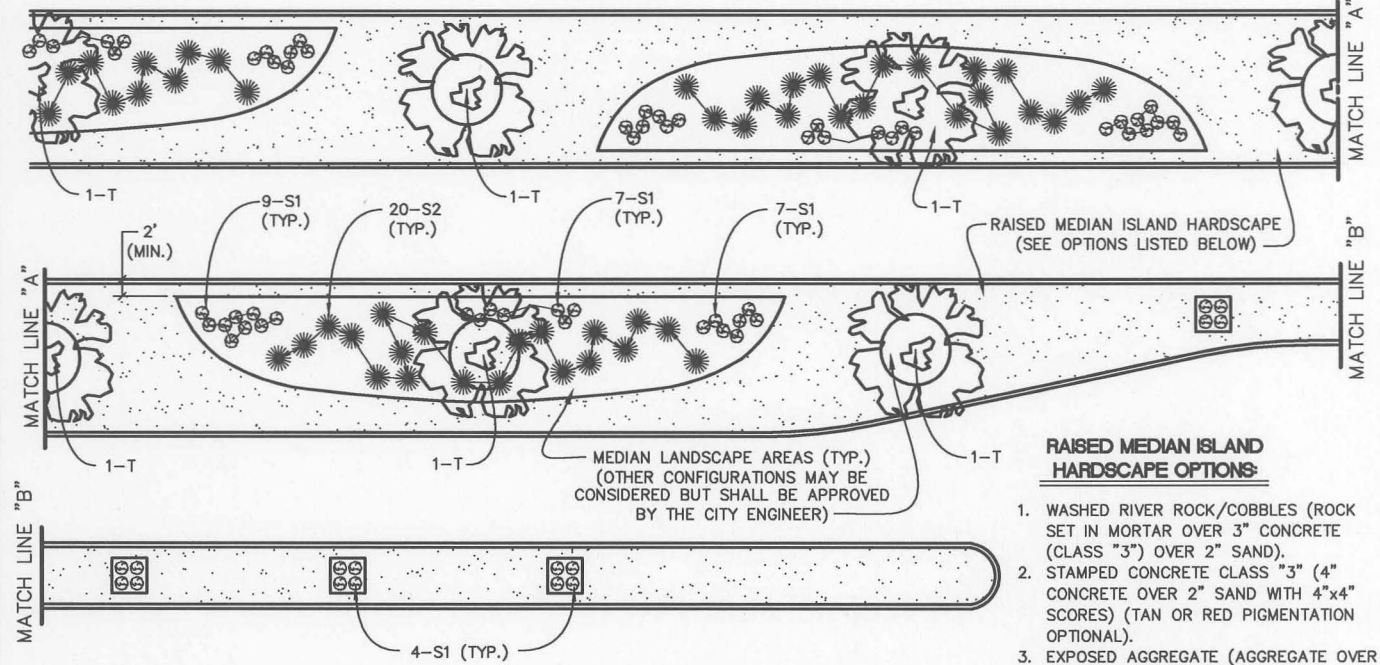

**TREES IN MEDIAN ISLANDS (T):**

- PYRUS ARISTOCRAT
- QUERCUS ILEX
- CRATAEGUS PHAENOPYRUM
- EUCALYPTUS FICIFOLIA
- CELTIS SINENSIS\*\*
- FRAXINUS VELUTINA "RAYWOOD"\*\*
- GINKGO BILOBA\*\*
- GLEDITSIA TRICANTHOS "SHADEMASTER\*\*
- LIQUIDAMBAR STYRACIFLUA "FESTIVAL, PALO ALTO, OR BURGUNDY\*\*
- PITTIOSPORUM UNDULATUM
- PRUNUS CERASIFERA "THUNDERCLOUD"
- WASHINGTONIA ROBUSTA
- (OTHER TREES MAY BE CONSIDERED SEE NOTE NO. 3)

\*\*DECIDUOUS TREES

**GROUND COVER OPTIONS (G):**

- HEDERA HELIX
- HEDERA CANARIENSIS
- TRACHELOSPERMUM JASMINOIDES (ALSO LOW VINING SHRUB)
- GAZANIA (MULTIPLE VARIETIES INCLUDING 'COPPER KING')
- AGAPANTHUS (MULTIPLE VARIETIES)
- CEANOTHUS 'YANKEE POINT', 'CARMEL CREEPER'
- ROSMARINUS OFFICINALIS
- BACCHARIS PILULARIS
- MYOPORUM PARVIFOLIUM
- COTONEASTER HORIZONTALIS
- LONICERA JAPONICA
- LANTANA MONTEVIDENSIS (MULTIPLE VARIETIES)
- CARPOBROTUS, OR OTHER FORMS OF ICEPLANTS
- (OTHER GROUND COVER MAY BE CONSIDERED, SEE NOTE NO. 3)

**SHRUB OPTIONS:**

**SMALL SHRUBS 24" OR UNDER (S1)**

- ROSMARINUS..(TRAILING WOODY GROUND COVER TYPE SHRUB)
- SANTOLINA..(HERBACEOUS)
- BUXUS MICROPHILA
- COTONEASTER HORIZONTALIS
- RAPHIOLEPIS INDICA 'BALLERINA' (AT TIMES EXCEEDS 3')
- CEANOTHUS GRISEUS HORIZONTALIS 'YANKEE POINT', 'CARMEL CREEPER'
- BACCHARIS PILULARIS (AT TIMES EXCEEDS 3')
- AGAPANTHUS 'PETER PAN' (ALSO USED AS GROUND COVER)
- TRACHELOSPERMUM JASMINOIDES (ALSO USED AS TRAILING GROUND COVER)
- BERBERIS BUXIFOLIA 'NANA'
- VIBURNUM DAVIDII
- (OTHER SHRUBS MAY BE CONSIDERED SEE NOTE NO. 3)

**LARGER SHRUBS (S2)**

- ESCALLONIA 'FRADESI
- XYLOSMA CONGESTUM
- PITTIOSPORUM EUGENIODES
- PITTIOSPORUM TOBIRA
- ABELIA 'EDWARD GOUCHER'
- NERIUM OLEANDER
- PHOTINIA FRASERI
- PHORMIUM TENAX
- COTONEASTER (MULTIPLE VARIETIES ACCEPTABLE)
- EUONYMOUS JAPONICA
- GREVILLEA 'NOELLI'
- MYOPORUM LAETUM
- ELEAGNUS PUNGENS
- CISTUS (MULTIPLE VARIETIES)
- COLEONEMA PULCHRUM
- RHAMNUS CALIFORNICA
- LIGUSTRUM LUCIDUM
- SOLLYA FUSIFORMIS
- (OTHER SHRUBS MAY BE CONSIDERED SEE NOTE NO. 3)

**RAISED MEDIAN ISLAND HARDSCAPE OPTIONS:**

1. WASHED RIVER ROCK/COBBLES (ROCK SET IN MORTAR OVER 3" CONCRETE (CLASS "3") OVER 2" SAND).
2. STAMPED CONCRETE CLASS "3" (4" CONCRETE OVER 2" SAND WITH 4"x4" SCORES) (TAN OR RED PIGMENTATION OPTIONAL).
3. EXPOSED AGGREGATE (AGGREGATE OVER 4" CONCRETE (CLASS "3") OVER 2" SAND).
4. BRICK OR OTHER LANDSCAPE PAVERS AS APPROVED BY THE CITY ENGINEER.

**GENERAL NOTES**

1. DRAWING NOT TO SCALE.
2. TREES SHALL BE PLANTED PER CITY STANDARD PLAN NO. 11.
3. OTHER PLANT MATERIALS SHALL BE APPROVED BY THE CITY ENGINEER PRIOR TO PLANTING.
4. \*LOMBARDY POPLAR TREES NOT PERMITTED IN CITY OF SALINAS (PER CITY CODE §3597).

**DEVELOPMENT & ENGINEERING SERVICES DEPARTMENT**  
ENGINEERING SERVICES DIVISION CITY OF SALINAS

<b>TITLE: RAISED MEDIAN ISLAND STANDARD PLANTING PLAN</b>		<b>STANDARD PLAN</b>
DESIGNED BY: STAFF	DATE <u>10/21/2008</u>	<b>13</b>
CADD BY: STAFF		
PROJECT MANAGER: FRANK A. AGUAYO, P.E.	 ROBERT C. RUSSELL, CITY ENGINEER R.C.E. 42871, EXPIRES 3-31-2010 MAINTENANCE SERVICES DIRECTOR	

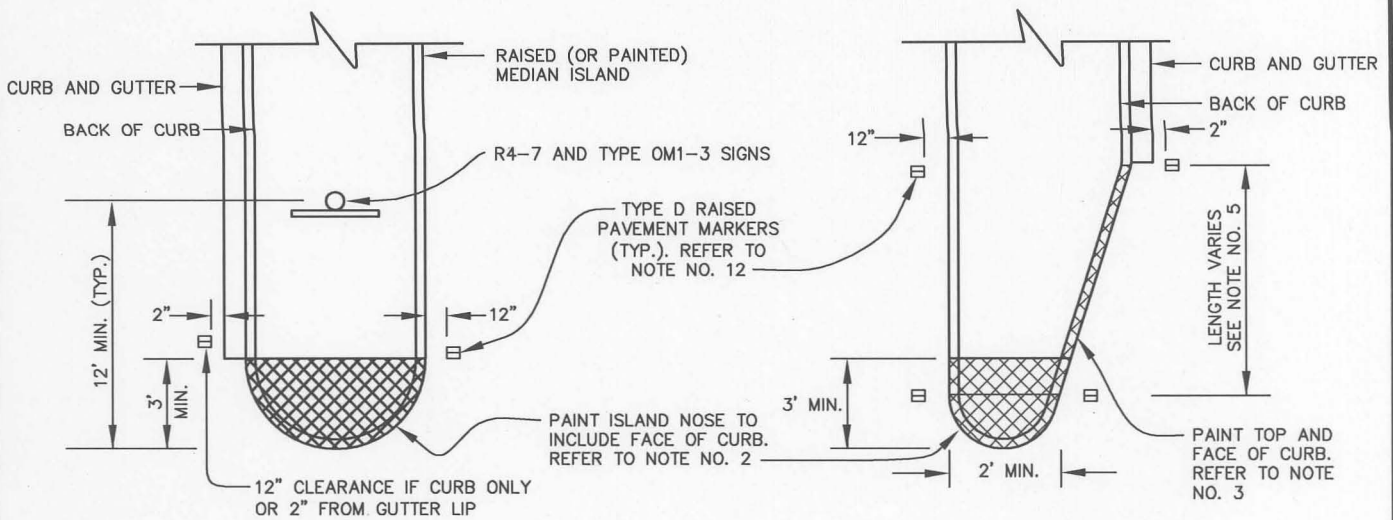

**EXISTING OR NEW ISLAND NOSE**

**EXISTING OR NEW TAPERED ISLAND**

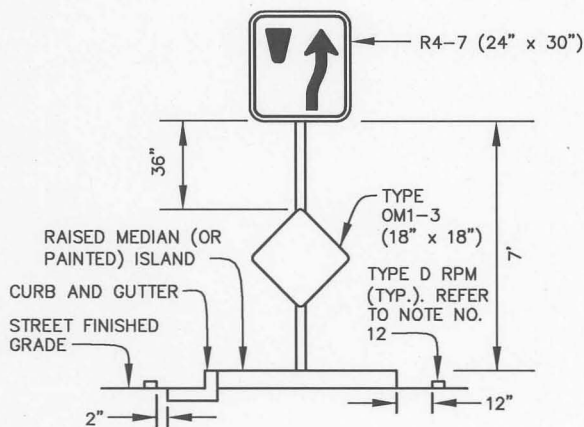

**TYPICAL INSTALLATION AT MEDIAN ISLAND NOSE**

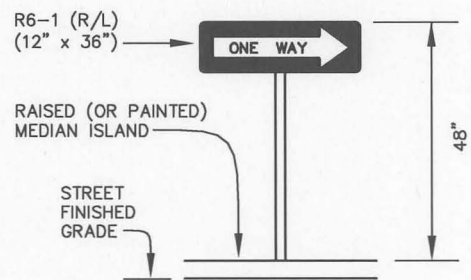

**TYPICAL INSTALLATION AT MEDIAN FOR COMMERCIAL DRIVEWAY EXIT**

**GENERAL NOTES**

1. DRAWING NOT TO SCALE.
2. PAINT ISLAND NOSE (TO INCLUDE FACE AND TOP OF CURB) WITH YELLOW REFLECTIVE PAINT WITH GLASS BEADS. DO NOT PAINT BEYOND FULL WIDTH OF ISLAND.
3. FOR TAPER AT ISLAND, PAINT TOP AND FACE OF CURB WITH WHITE REFLECTIVE PAINT WITH GLASS BEADS. DO NOT PAINT BEYOND FULL WIDTH OF ISLAND.
4. FOR ADDITIONAL STRIPING AND RAISED PAVEMENT MARKING REQUIREMENTS AT RAISED MEDIAN ISLAND REFER TO DETAIL K AND PAINTED MEDIAN ISLAND REFER TO DETAIL G ON THE CITY STANDARD PLAN NO. 37A.
5. TAPER LENGTH ON THE TAPERED ISLAND SHALL BE DETERMINED BY THE CITY ENGINEER.
6. INSTALL TYPE D, TWO WAY YELLOW REFLECTIVE (HIGH INTENSITY) RAISED PAVEMENT MARKERS PER CITY STANDARD PLAN NO. 37A AND 37B.
7. TRAFFIC SIGNS SHALL BE CONSTRUCTED OF 0.08\"/>
- 8. TRAFFIC SIGNS SHALL BE 3M DIAMOND GRADE CUBED REFLECTIVE SHEETING SERIES 4090 (OR APPROVED EQUAL BY THE CITY ENGINEER). THE REFLECTIVE SHEETING SHALL CONFORM WITH THE FEDERAL SPECIFICATIONS L-S300A.
- 9. R4-7 SIGN SHALL HAVE A WHITE BACKGROUND WITH A BLACK BORDER AND LEGENDS, WITH EVERYTHING REFLECTIVE.
- 10. TYPE OM1-3 SIGN SHALL BE YELLOW 3M DIAMOND GRADE CUBED REFLECTIVE SHEETING.
- 11. R6-1 SIGN SHALL HAVE A BLACK BACKGROUND WITH A WHITE ARROW AND BLACK LETTERS, WITH EVERYTHING REFLECTIVE.
- 12. REFER TO DETAIL G OR DETAIL K ON CITY STANDARD PLAN NO. 37A FOR DIMENSION OF RAISED PAVEMENT MARKERS FROM RAISED OR PAINTED MEDIAN ISLAND.

**DEVELOPMENT & ENGINEERING SERVICES DEPARTMENT**

ENGINEERING SERVICES DIVISION

CITY OF SALINAS

TITLE: **MEDIAN ISLAND DETAILS**

**STANDARD PLAN**

DESIGNED BY:  
STAFF

DATE 10/21/2008

CADD BY:  
STAFF

*Robert C. Russell*

PROJECT MANAGER:  
FRANK A. AGUAYO, P.E.

ROBERT C. RUSSELL, CITY ENGINEER  
R.C.E. 42871, EXPIRES 3-31-2010

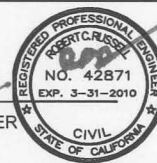

**14**

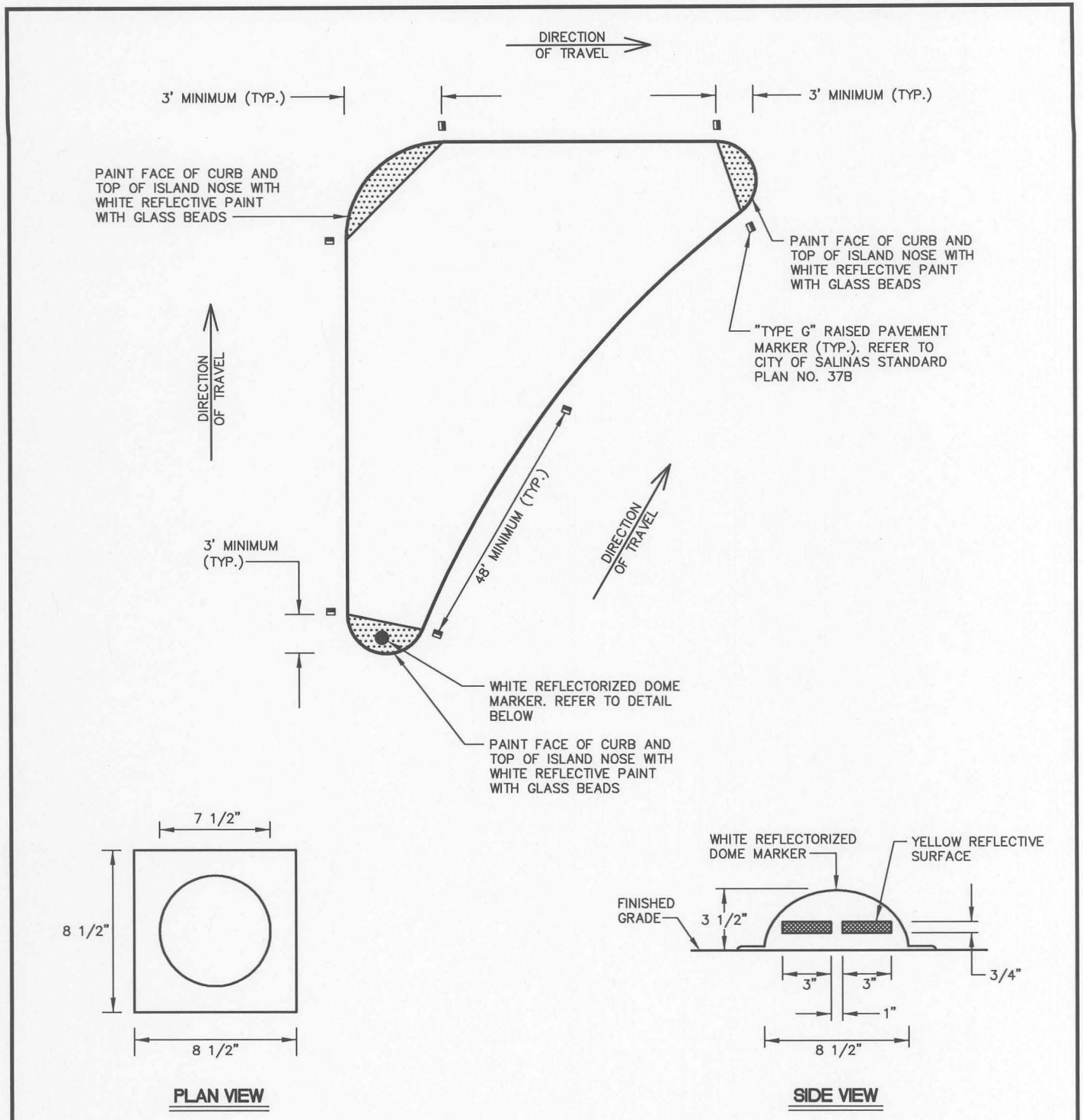

**GENERAL NOTES**

1. DRAWING NOT TO SCALE.
2. MINOR VARIATIONS IN DIMENSIONS ARE SUBJECT TO APPROVAL BY THE CITY ENGINEER.
3. WHITE REFLECTIVE PAINT WITH GLASS BEADS SHALL BE PER THE CITY STANDARD SPECIFICATIONS.

**DEVELOPMENT & ENGINEERING SERVICES DEPARTMENT**  
 ENGINEERING SERVICES DIVISION CITY OF SALINAS

**TITLE: PORK CHOP ISLAND AND REFLECTIVE MARKER**

**STANDARD PLAN**

DESIGNED BY:  
STAFF

CADD BY:  
STAFF

PROJECT MANAGER:  
FRANK A. AGUAYO, P.E.

DATE 10/21/2008

*Robert C. Russell*

ROBERT C. RUSSELL, CITY ENGINEER  
 R.C.E. 42871, EXPIRES 3-31-2010



**15**

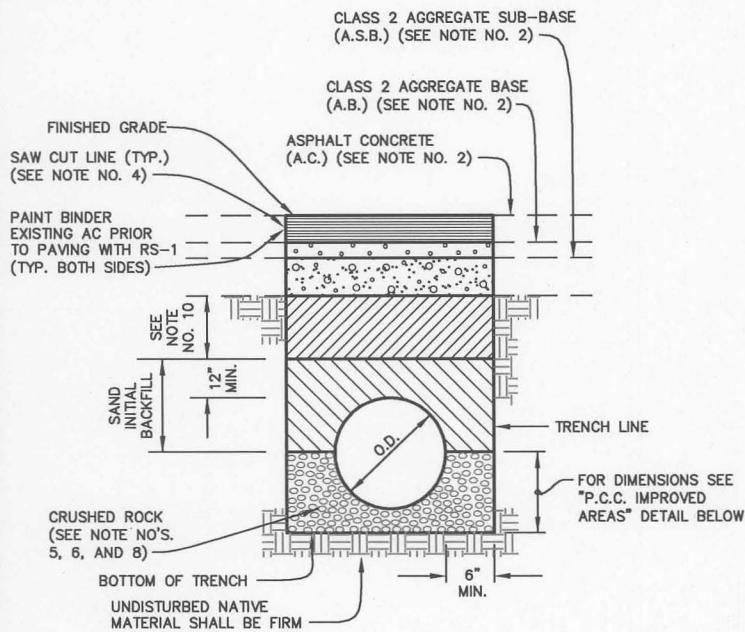

**A.C. IMPROVED AREAS**

**GENERAL NOTES**

1. DRAWING NOT TO SCALE.
2. ON IMPROVED STREETS THE THICKNESS OF THE A.C., A.B., AND A.S.B. SHALL BE EQUIVALENT TO THE EXISTING ON A.C. PLUS 1" PAVEMENT.
3. FOR BACKFILL MATERIALS AND COMPACTION METHODS SEE SECTION 19-3 OF THE CITY STANDARD SPECIFICATIONS. INTERMEDIATE BACKFILL SHALL BE COMPACTED TO 95% RELATIVE COMPACTION IN UNIMPROVED AREAS.
4. ALL STREET CUTS SHALL BE NEATLY SAWCUT ON TRUE LINE TO 1 1/2" MINIMUM DEPTH.
5. TWO SACK CEMENT SLURRY BACKFILL SHALL BE USED AS INTERMEDIATE BACKFILL IF TRENCH IS LESS THAN 18" WIDE OR IN PATCH AREAS LESS THAN 100 SQ FT.
6. CRUSHED ROCK BEDDING SHALL CONFORM WITH AGGREGATE GRADATIONS OF SECTION 19-4.022A (1) OF THE CITY STANDARD SPECIFICATIONS. CRUSHED ROCK BACKFILL SHALL BE PROVIDED WITH JETTED SAND PAVED AREAS.
7. STRUCTURAL SECTION REQUIREMENTS SHALL NOT APPLY TO UNIMPROVED AREAS.
8. CRUSHED ROCKS MAY BE REPLACED WITH INTERMEDIATE BACKFILL MATERIAL FOR ALL PIPE INSTALLATIONS OTHER THAN STORM DRAIN LINES AND SANITARY SEWER LINES PROVIDED NOTE NO. 4 DOES NOT APPLY.
9. CRUSHED ROCK OR SLURRY CEMENT BACKFILL SHALL NOT BE REQUIRED IF MONOLITHIC CONCRETE PIPE IS INSTALLED.
10. COMPACTED INTERMEDIATE BACKFILL (SEE NOTES NO. 2 AND NO. 4).
11. TRENCH WIDTH SHOWN ON PLANS FOR PAVEMENT RESTORATION MAY VARY FROM ACTUAL WIDTH REQUIRED TO PERFORM NECESSARY WORK DEPENDING UPON METHOD FOR TRENCH SHORING/PROTECTION USED BY CONTRACTOR.
12. ALL PAVEMENT MARKINGS AND RAISED PAVEMENT MARKERS OBLITERATED DURING CONSTRUCTION SHALL BE REPLACED BY THE CONTRACTOR PER CITY STANDARD PLAN NO.'S 37A, 37B, 38, 39, 40, AND 41.
13. TRENCH DIMENSION FOR ROUNDED BOTTOM CAN BE ADJUSTED SUBJECT TO CITY ENGINEER'S APPROVAL.

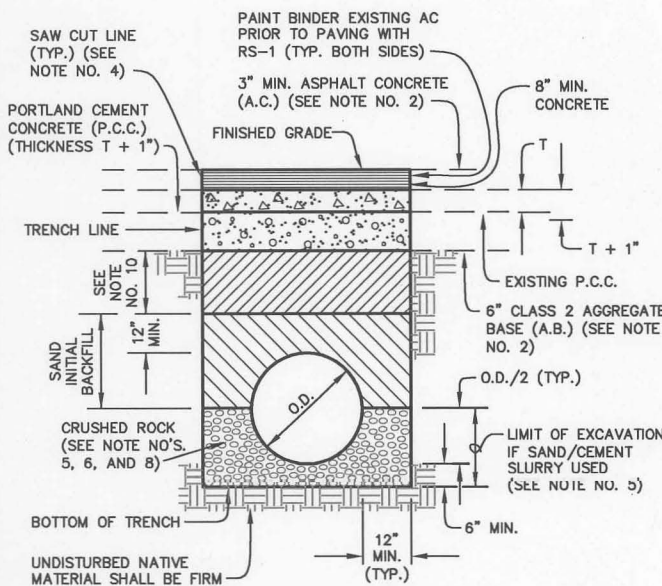

**P.C.C. IMPROVED AREAS**

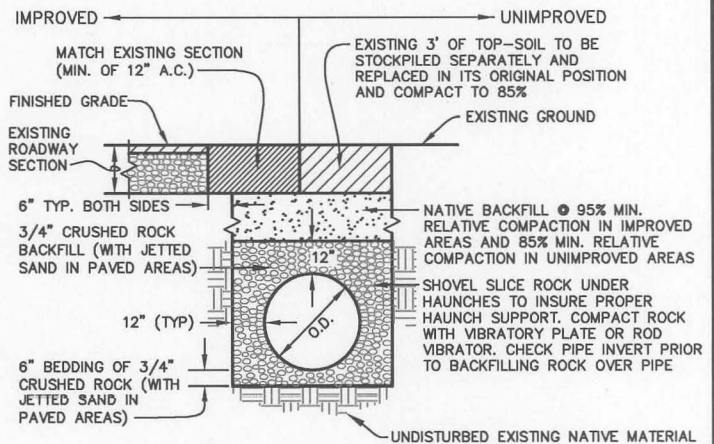

**TYPICAL TRENCH/BACKFILL SECTION FOR P.V.C. AND H.D.P.E. PIPE**

<b>DEVELOPMENT &amp; ENGINEERING SERVICES DEPARTMENT</b>		CITY OF SALINAS
ENGINEERING SERVICES DIVISION		
<b>TITLE: TRENCH BACKFILL AND SURFACE RESTORATION</b>		<b>STANDARD PLAN</b>
DESIGNED BY: STAFF	DATE: 10/21/2008	<b>16</b>
CADD BY: STAFF	<i>Robert C. Russell</i>	
PROJECT MANAGER: FRANK A. AGUAYO, P.E.	ROBERT C. RUSSELL, CITY ENGINEER R.C.E. 42871, EXPIRES 3-31-2010	



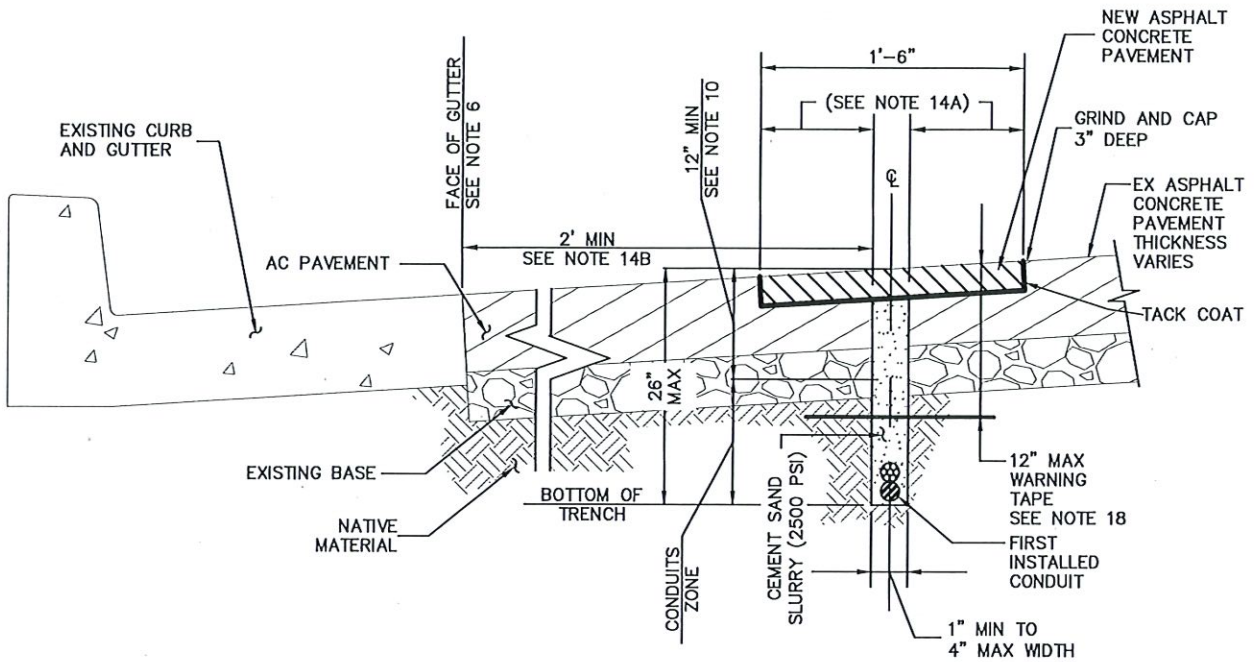

**GENERAL NOTES**

1. MICRO-TRENCHING SHALL ONLY BE USED TO INSTALL FIBER CONDUITS.
2. MICRO-TRENCHING SHALL NOT BE ALLOWED IN CONCRETE PAVED STREETS, SIDEWALKS, CURBS AND GUTTERS.
3. ALL WORK SHALL BE CONSTRUCTED IN ACCORDANCE WITH THE CITY STANDARD SPECIFICATIONS.

**LIMITS OF REMOVALS, TRENCH WIDTH, AND LOCATION**

4. THE MICRO-TRENCH SHALL BE CONSTRUCTED WITH CONTINUOUS UNIFORM STRAIGHT AND NEAT EDGES.
5. MICRO-TRENCH ALIGNMENTS SHALL CONSIST OF RUNS PARALLEL TO THE CENTERLINE OF THE STREET. STREET CROSSING MAY BE DONE PROVIDED THE ALIGNMENT IS PERPENDICULAR TO THE STREET CENTERLINE TO THE EXTENT POSSIBLE.
6. THE EDGE OF THE MICRO-TRENCH SHALL BE A MINIMUM OF 24-INCHES FROM THE EXISTING FACE OF THE GUTTER, EXISTING CONCRETE STRUCTURE, OR CURB IF GUTTER IS NOT PRESENT.
7. THE MICRO-TRENCH WIDTH SHALL BE A MINIMUM OF 1-INCH AND A MAXIMUM OF 4-INCHES.
8. MICRO-TRENCHING MAY BE PERMITTED UPON THE CITY ENGINEER'S DISCRETION ON SPECIAL PAVEMENTS SUCH AS DECORATIVE ASPHALT PAVING, AND THROUGH EXISTING IMPROVEMENTS SUCH AS PERPENDICULAR TO SPEED BUMPS. SPECIAL PAVEMENTS AND EXISTING IMPROVEMENTS SHALL BE RESTORED IN KIND AS APPROVED BY THE CITY ENGINEER. HOWEVER, MICRO-TRENCHING THROUGH EXISTING CURB, GUTTER, CROSS GUTTER, BUS PAD, SIDEWALK, CURB EXTENSION, BUS BULB, TRUCK PILLOW, RAISED CROSSWALK, ISLAND, MINI-ROUNDBOUT, OR SIMILAR ELEMENTS IS NOT PERMITTED.
9. UP TO TWO (2) VERTICALLY STACKED CONDUITS CAN BE PLACED WITHIN A MICRO-TRENCH.
10. THE CONDUIT SHALL BE INSTALLED AT A MINIMUM DEPTH OF 12-INCHES BELOW THE EXISTING AC PAVEMENT SURFACE, AT LEAST 1-INCH BELOW THE BOTTOM OF THE AC PAVEMENT, AND THE BOTTOM OF THE MICRO-TRENCH SHALL BE AT A MAXIMUM DEPTH OF 26-INCHES BELOW THE EXISTING AC PAVEMENT SURFACE.
11. ANCHORS/SPACERS SHALL BE PLACED AT A MAXIMUM OF 10- FEET APART ALONG THE ALIGNMENT TO ENSURE THE CONDUIT DOES NOT RISE FROM THE BOTTOM OF THE MICRO-TRENCH AND DOES NOT TOUCH THE WALLS OF THE MICRO-TRENCH DURING INSTALLATION.

**PUBLIC WORKS DEPARTMENT**

ENGINEERING SERVICES DIVISION

CITY OF SALINAS

TITLE: **MICROTRENCHING**

**STANDARD PLAN**

DESIGNED BY:  
STAFF

CADD BY:  
STAFF

PROJECT MANAGER:  
J. HERNANDEZ

DATE: *1/10/23*

*Adriana Robles*

ADRIANA ROBLES  
CITY ENGINEER, R.C.E. 69142



**16B**

**GENERAL NOTES CONTINUED**

**BACKFILL**

12. ALL MICRO-TRENCHES SHALL BE COMPLETELY BACKFILLED WITH A CEMENT SAND SLURRY 2500 PSI TO FINISH GRADE BY THE END OF THE WORK DAY.

**GRIND AND RESURFACE SECTION**

13. COMMENCEMENT OF SURFACE PREPARATION SUCH AS GRINDING/CHIPPING FOR ASPHALT CONCRETE PAVING REPLACEMENT WILL OCCUR NO SOONER THAN 48 HOURS AFTER SLURRY BACKFILL OF TRENCH. FIELD CONDITIONS OR MATERIAL USED MAY NECESSITATE A LONGER WAIT AS DETERMINED BY THE INSPECTOR.

14. AS SOON AS BACKFILL HAS CURED, NOT TO EXCEED 30 CALENDAR DAYS, ASPHALT CONCRETE SHALL BE GROUND AND CAPPED AS FOLLOWS:

- A. EXISTING AC AND SLURRY BACKFILL SHALL BE GROUND DOWN 3-INCHES, FOR A WIDTH OF 18-INCHES BUT NO LESS THAN 7-INCHES FROM BOTH EDGES OF THE MICRO-TRENCH AND RESURFACED WITH ASPHALT AND BINDER GRADE PER CITY STANDARD SPECIFICATIONS SECTION 39.
- B. WHEN THE CAP LIMIT IS WITHIN 2- FEET OR LESS FROM THE GUTTER FACE, CURB, SLAB OR STRUCTURE, THE CAP LIMIT SHALL EXTEND TO THAT ITEM.
- C. TACK COAT ALL EDGES WITH EITHER SS-1H EMULSIFIED ASPHALT OR PG 64-10 PAVING ASPHALT IMMEDIATELY BEFORE THE ADJOINING ASPHALT CONCRETE IS PLACED.
- D. WHERE ANGULAR CROSSING OR ANY LENGTH-WISE CUTS OF A BIKE LANE OCCUR BY MICRO-TRENCHING, THE CAPPING LIMITS SHALL EXTEND THE FULL WIDTH OF THE BIKE LANE. PERPENDICULAR CROSSINGS MAY RECEIVE TYPICAL CAPPING WIDTH PER NOTE 14.A AND 14.B. PAVEMENT MARKINGS SHALL BE RESTORED IN KIND. WHERE NO BIKE LANE MARKINGS EXIST, CONTRACTOR SHALL CONSULT WITH CITY ENGINEER TO DETERMINE LOCATION OF ANY PLANNED BIKE LANES SO THAT IMPACT OF PAVEMENT SURFACE MAY BE AVOIDED.
- E. PAVEMENT SHALL BE LEVEL WITH ADJACENT ROADWAY ELEVATIONS AND SHALL PROVIDE A SMOOTH SURFACE PER CITY STANDARD SPECIFICATIONS SECTION 39.

**VAULTS AND SERVICE CONNECTIONS**

15. CONNECTION TO SERVICE LATERALS, JUNCTION BOXES, ETC., SHALL BE DONE SUCH THAT CURB AND GUTTER IS NOT DISTURBED, SETTLED OR DAMAGED. REMOVAL LIMITS OF SIDEWALK SHALL FOLLOW APPLICABLE STANDARDS AND REQUIREMENTS AS APPROVED BY THE CITY ENGINEER.

16. THE USE OF HYDRO-JETTING IS NOT PERMITTED. TRENCHLESS METHODS SHALL NOT CREATE A VOID TWO TIMES GREATER THAN CONDUIT. VOID SHALL BE COMPACTED AND BACKFILLED WITH APPROVED CONTROLLED LOW-STRENGTH MATERIAL (CLSM).

**IDENTIFICATION**

17. EACH MICRO-TRENCH SHALL BE IDENTIFIED WITH A METAL IDENTIFICATION TAG LISTING THE OWNER, YEAR OF CONSTRUCTION, AND INCLUDE THE WORDS "NOT A SURVEY POINT". IF THE WORK IS MORE THAN 50 FEET IN LENGTH, PLACE THE TAG NEAR EACH END OF THE MICRO-TRENCH AND AT INTERVALS NOT TO EXCEED 50 FEET.

18. GRAINGER TAPE FIBER OPTIC-ORANGE 5 MIL THICKNESS OR EQUIVALENT SHALL BE INSTALLED 12-INCHES BELOW THE SURFACE ABOVE THE CONDUIT.

**PUBLIC WORKS DEPARTMENT**

ENGINEERING SERVICES DIVISION

CITY OF SALINAS

TITLE: **MICROTRENCHING**

**STANDARD PLAN**

DESIGNED BY:  
STAFF

CADD BY:  
STAFF

PROJECT MANAGER:  
A. ROBLES, P.E.

DATE 1/10/23

*Adriana Robles*

ADRIANA ROBLES  
CITY ENGINEER, R.C.E. 69142

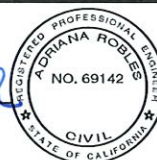

**16B**



**GENERAL NOTES**

1. DRAWING NOT TO SCALE.
2. CAST-IN-PLACE PIPE SHALL CONFORM WITH SECTION 63 OF THE CITY STANDARD SPECIFICATIONS.
3. CONSTRUCT CLASS "2" P.C.C. PER SECTION 51 OF THE CITY STANDARD SPECIFICATIONS.

**TABLE OF INTERNAL DIAMETER AND WALL THICKNESS**

NOMINAL INTERNAL DIAMETER IN INCHES	MINIMUM WALL THICKNESS, T IN INCHES	T <sub>1</sub> INCHES
24 TO 30	3	3 3/4
33 TO 36	3 1/2	4 1/4
42	4	4 3/4
48	5	6 1/2
54	5 1/2	7 1/2
60	6	9
66	6 1/2	9
72	7	9
84	8	9
96	9	10 1/2

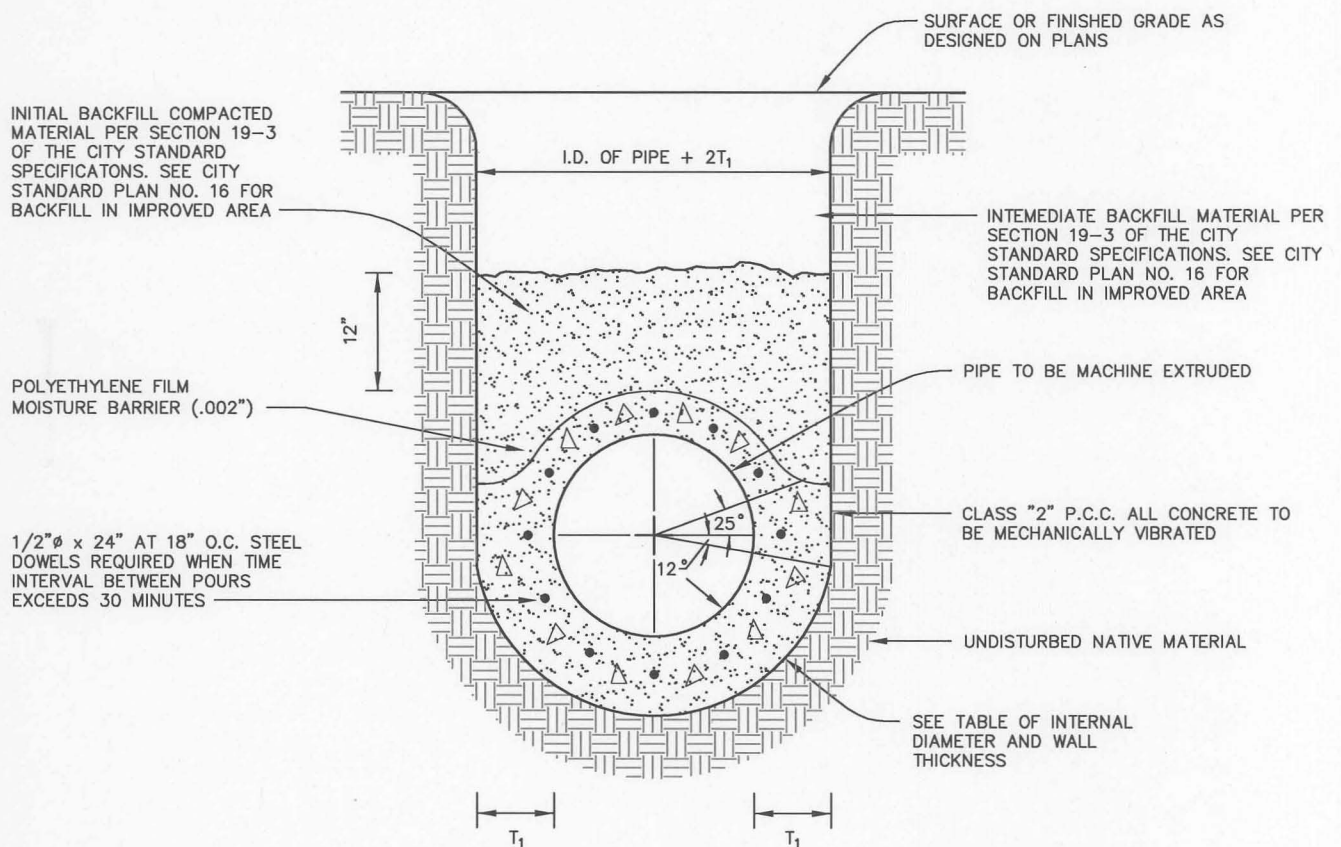

**DEVELOPMENT & ENGINEERING SERVICES DEPARTMENT**  
 ENGINEERING SERVICES DIVISION CITY OF SALINAS

<b>TITLE: CAST-IN-PLACE CONCRETE PIPE</b>		<b>STANDARD PLAN</b>
DESIGNED BY: STAFF	DATE <u>10/21/2008</u>	<b>17</b>
CADD BY: STAFF	<i>Robert Russell</i>	
PROJECT MANAGER: FRANK A. AGUAYO, P.E.	ROBERT C. RUSSELL, CITY ENGINEER R.C.E. 42871, EXPIRES 3-31-2010	



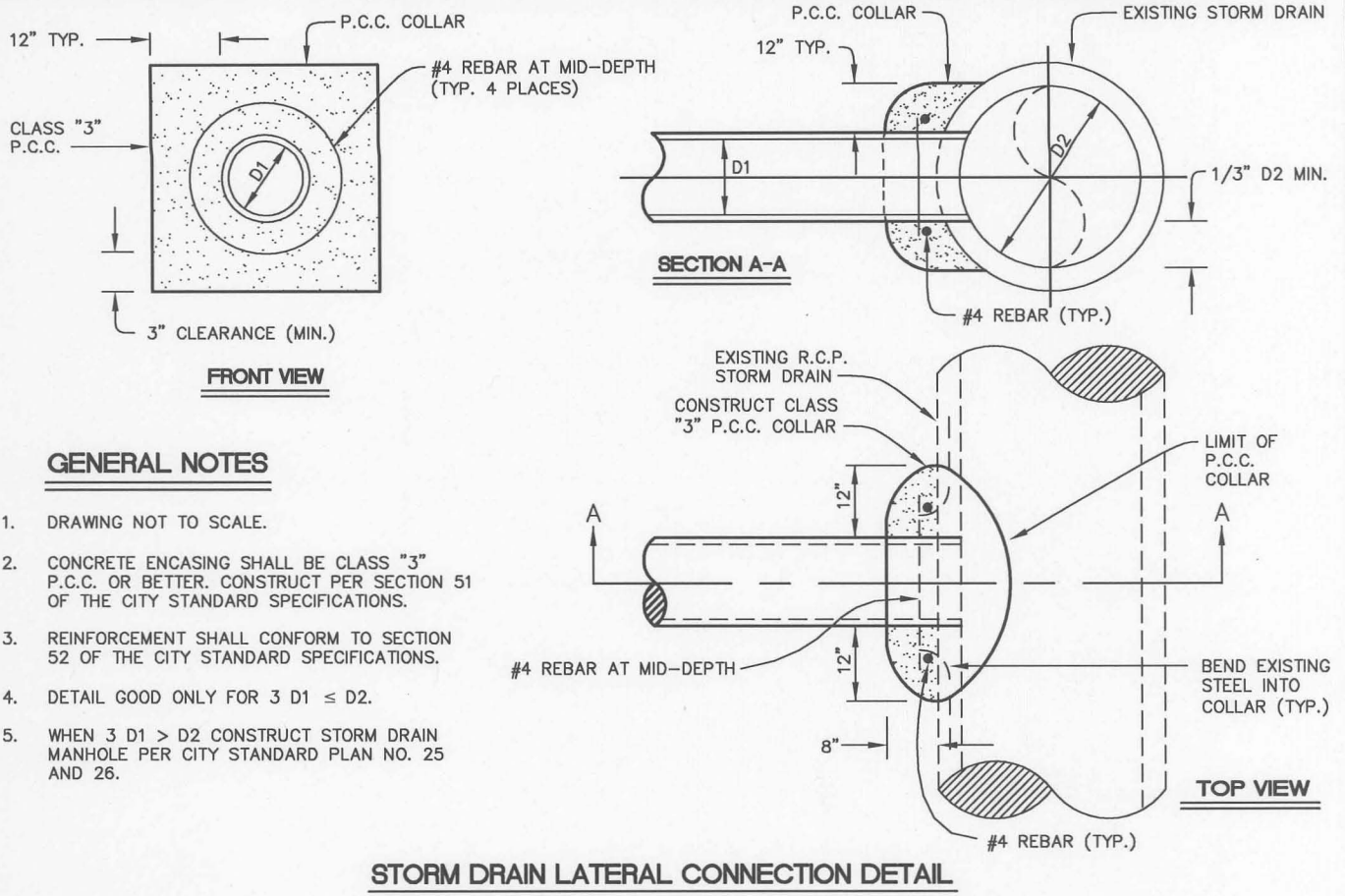

**GENERAL NOTES**

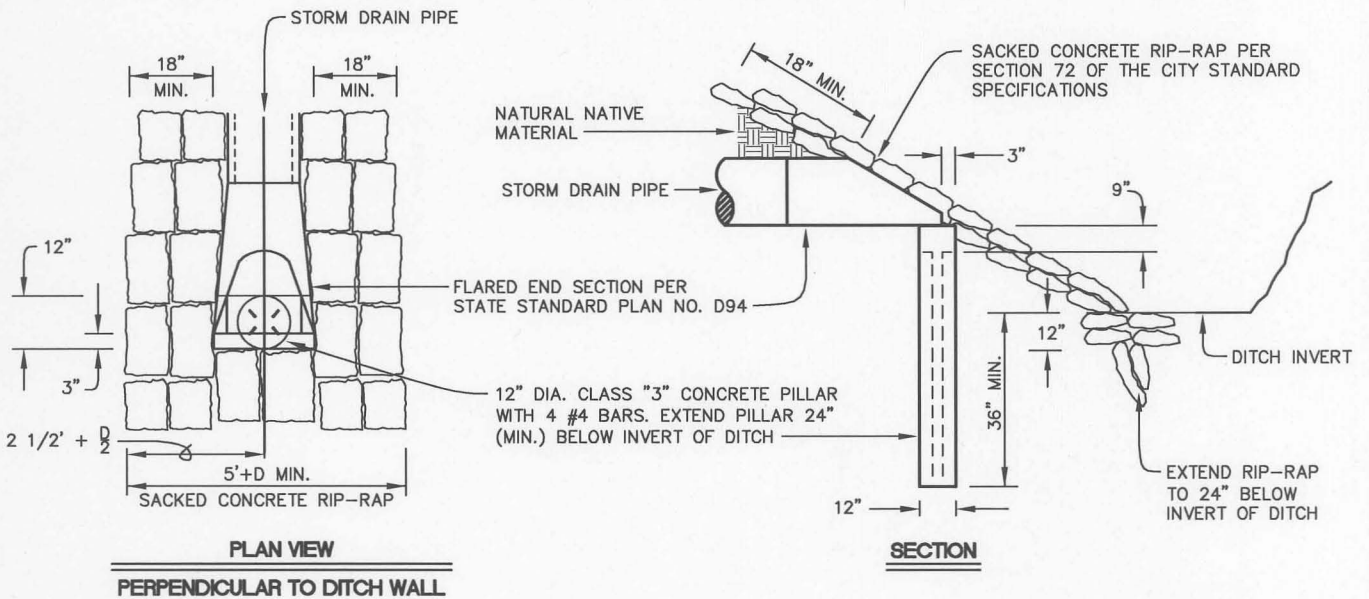

1. DRAWING NOT TO SCALE.
2. CONCRETE ENCASING SHALL BE CLASS "3" P.C.C. OR BETTER. CONSTRUCT PER SECTION 51 OF THE CITY STANDARD SPECIFICATIONS.
3. REINFORCEMENT SHALL CONFORM TO SECTION 52 OF THE CITY STANDARD SPECIFICATIONS.
4. DETAIL GOOD ONLY FOR  $3 D1 \leq D2$ .
5. WHEN  $3 D1 > D2$  CONSTRUCT STORM DRAIN MANHOLE PER CITY STANDARD PLAN NO. 25 AND 26.



NOTE: ALTERNATIVE DESIGN MAY BE SUBMITTED TO THE CITY ENGINEER FOR APPROVAL.

**PIPE OUTLET DETAIL AT DITCH**

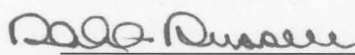
DEVELOPMENT & ENGINEERING SERVICES DEPARTMENT  
 ENGINEERING SERVICES DIVISION CITY OF SALINAS

TITLE: <b>MISCELLANEOUS STORM DRAIN DETAILS</b>		<b>STANDARD PLAN</b>  <h1>18</h1>
DESIGNED BY: STAFF	DATE: 10/21/2008	
CADD BY: STAFF	 ROBERT C. RUSSELL, CITY ENGINEER R.C.E. 42871, EXPIRES 3-31-2010	
PROJECT MANAGER: FRANK A. AGUAYO, P.E.		



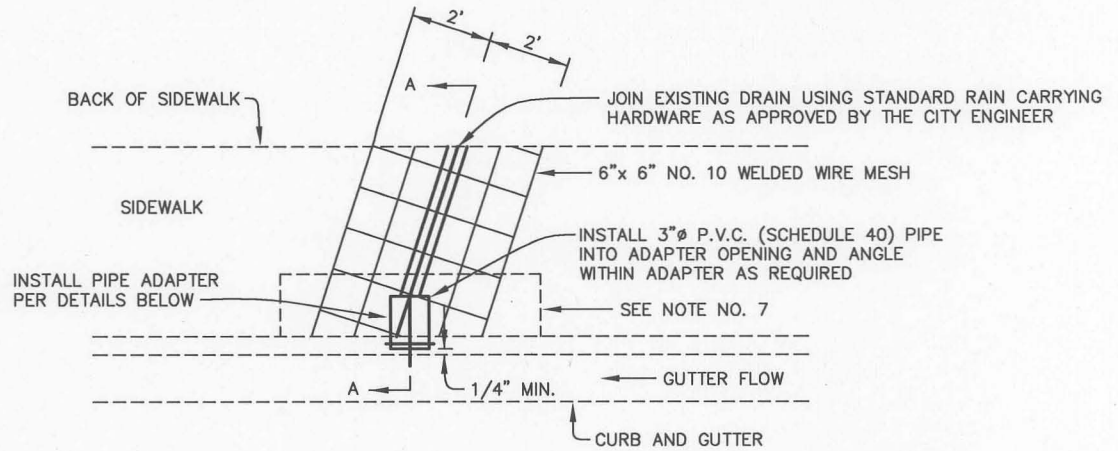

**PLAN**

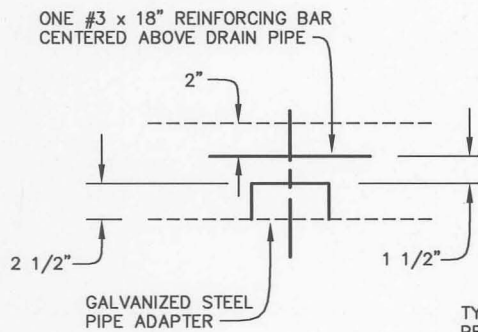

**PROFILE**

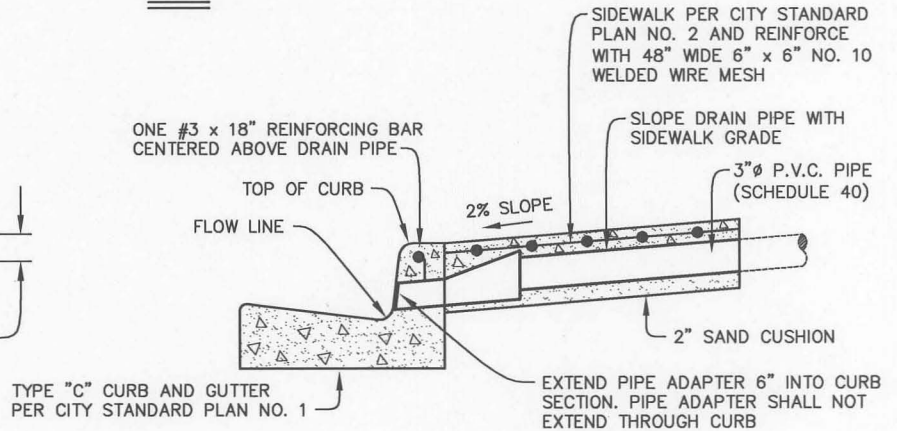

**SECTION A-A**

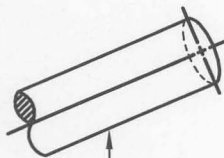

INSTALL 3" P.V.C. PIPE (SCHEDULE 40) 1" MIN. INTO PIPE ADAPTER OPENING (OR APPROVED EQUAL BY THE CITY ENGINEER)

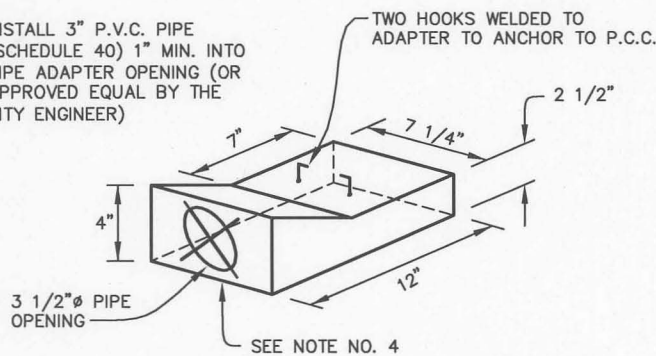

**PIPE ADAPTER DETAIL**

**GENERAL NOTES**

1. DRAWING NOT TO SCALE.
2. P.V.C. PIPE SHALL BE SCHEDULE 40.
3. CONTRACTOR MAY, AT HIS/HER OPTION, INSTALL TWO CURB DRAIN PIPES INTO AN ADAPTER HAVING TWO 3" PIPE ADAPTER OPENING.
4. PIPE ADAPTER SHALL BE FABRICATED FROM 14 GA. GALVANIZED STEEL.
5. WRAP JUNCTURE OF PIPE AND ADAPTER WITH DUCT TAPE TO PREVENT INTRUSION OF CONCRETE DURING INSTALLATION.
6. EXISTING SIDEWALK FOR CURB DRAIN INSTALLATIONS SHALL BE REMOVED TO NEAREST SCORE LINES.
7. WHERE NO SIDEWALK IS TO BE REPLACED, CONSTRUCT 18" x 54" REINFORCED CONCRETE PAD ADJACENT TO BACK OF CURB.
8. ALTERNATE DESIGN/MATERIALS MAY BE SUBMITTED TO THE CITY ENGINEER FOR APPROVAL.

**DEVELOPMENT & ENGINEERING SERVICES DEPARTMENT**

ENGINEERING SERVICES DIVISION

CITY OF SALINAS

TITLE: <b>CURB DRAIN</b>		STANDARD PLAN	
DESIGNED BY: STAFF	DATE: 10/21/2008		
CADD BY: STAFF	<i>Robert C. Russell</i>		
PROJECT MANAGER: FRANK A. AGUAYO, P.E.	ROBERT C. RUSSELL, CITY ENGINEER R.C.E. 42871, EXPIRES 3-31-2010		

**19**

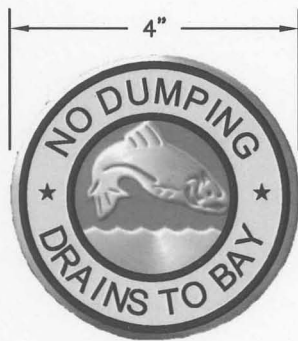
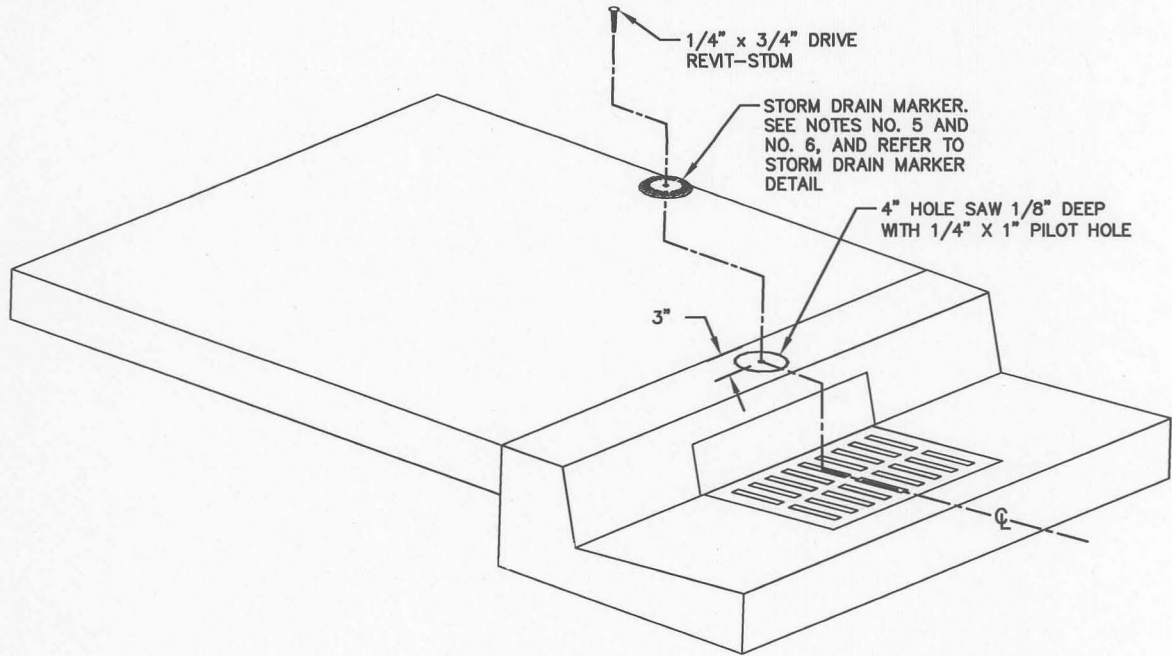

**STORM DRAIN MARKER DETAIL**

**GENERAL NOTES**

1. DRAWING NOT TO SCALE.
2. THE STORM DRAIN MARKER SHALL BE CENTERED ABOVE THE STORM DRAIN CATCH BASIN AS SHOWN ABOVE.
3. DRILL A 4" X 1/8" HOLE USING A CDB-4 (OR EQUIVALENT) HOLE SAW. THE PILOT HOLE SHALL BE 1/4" X 1". BRUSH WORK AREA SO THAT IT IS FREE OF DUST OR DEBRIS PRIOR TO NEXT STEP.
4. INSERT DR-250 1/4" X 3/4" DRIVE RIVET-STDM (OR EQUIVALENT) INTO STORM DRAIN MARKER, APPLY SILKABOND ADHESIVE TO UNDERSIDE OF STORM DRAIN MARKER. PLACE STORM DRAIN MARKER ON TOP OF CURB USING PILOT HOLE FOR ALIGNMENT. DRIVE RIVET FLUSH WITH STORM DRAIN MARKER USING A HAMMER. REMOVE EXCESS ADHESIVE FROM STORM DRAIN MARKER BEFORE ADHESIVE HARDENS.
5. THE STAINLES STEEL STORM DRAIN MARKER SHALL BE ALMETEK PART NUMBER SDS4R0231BLNAH, OR APPROVED EQUAL BY THE CITY ENGINEER.
6. WHEN A METAL HOOD IS ABOVE THE CATCH BASIN THE STORM DRAIN MARKER SHALL BE PLACED ON TOP OF THE CURB NO MORE THAN 6" FROM THE LEFT OR RIGHT OUTER EDGE OF THE HOOD.

**DEVELOPMENT & ENGINEERING SERVICES DEPARTMENT**  
 ENGINEERING SERVICES DIVISION CITY OF SALINAS

<b>TITLE: STORM DRAIN MARKER INSTALLATION</b>		<b>STANDARD PLAN</b>
DESIGNED BY: STAFF	DATE <u>10/21/2008</u>	<b>20</b>
CADD BY: STAFF	<i>Robert Russell</i>	
PROJECT MANAGER: FRANK A. AGUAYO, P.E.	ROBERT C. RUSSELL, CITY ENGINEER R.C.E. 42871, EXPIRES 3-31-2010	



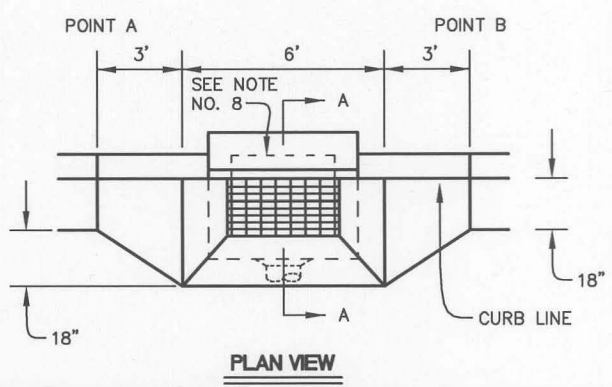
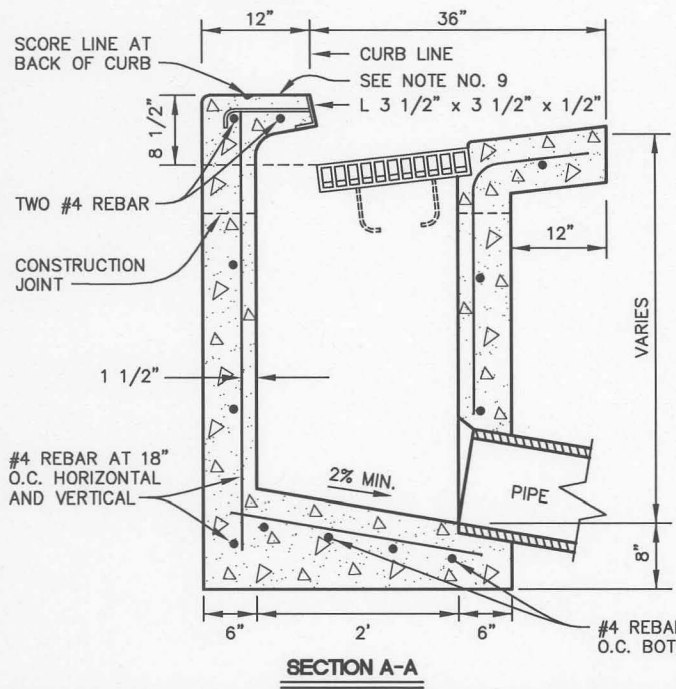
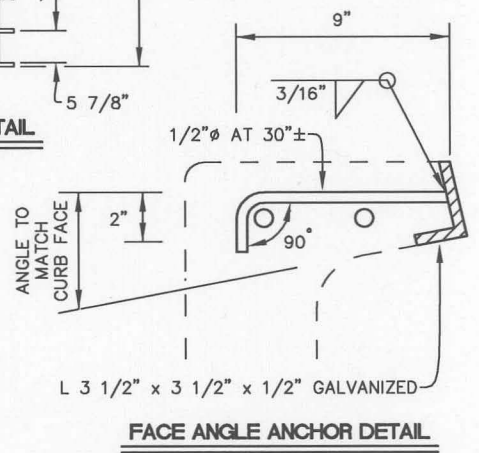
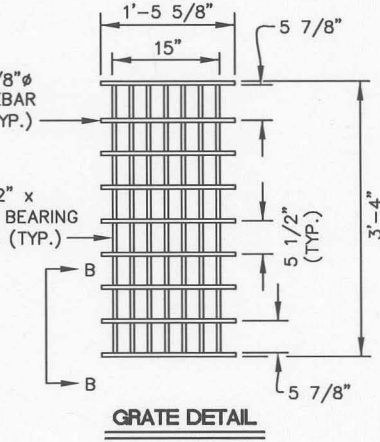
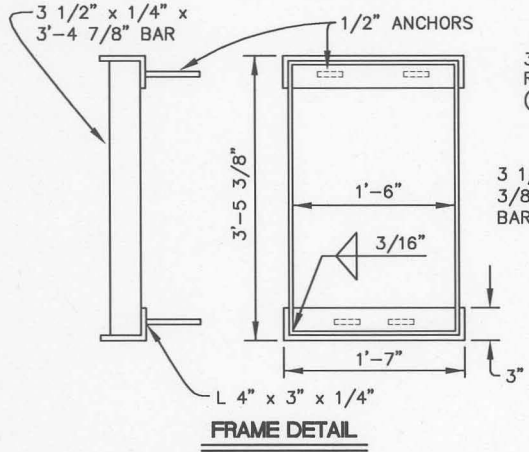
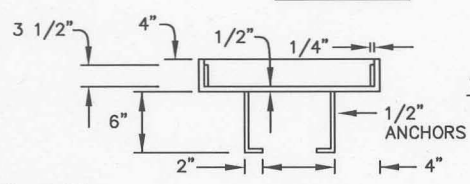
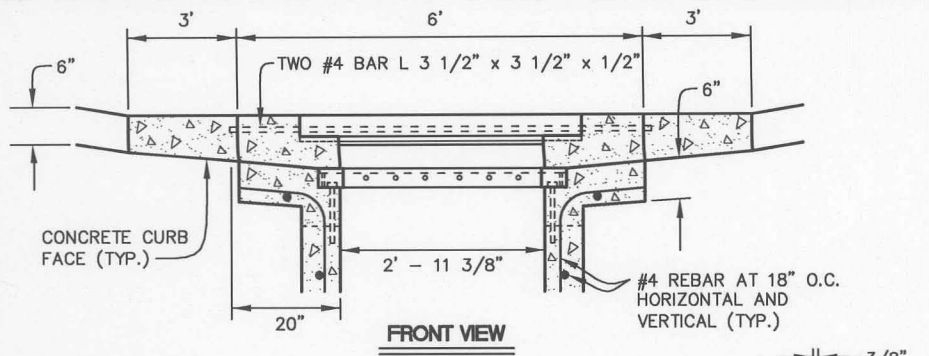

**GENERAL NOTES**

1. DRAWING NOT TO SCALE.
2. ALL WORK AND MATERIALS SHALL BE IN ACCORDANCE WITH SECTION 51 OF THE CITY STANDARD SPECIFICATIONS.
3. ALL CONCRETE SHALL BE CLASS "2" P.C.C. IN ACCORDANCE WITH THE CITY STANDARD SPECIFICATIONS.
4. FRAME AND GRATE SHALL CONFORM TO CALTRANS TYPE 18-9X GALVANIZED WELDED STEEL FRAME AND GRATE AND RATED FOR H-20 LOADING.
5. CURB AND GUTTER FROM POINT A TO POINT B SHALL BE INCLUDED IN THE CATCH BASIN FOR PAYMENT PURPOSES.
6. CONTRACTOR MAY SUBSTITUTE A PRECAST CATCH BASIN APPROVED BY THE CITY ENGINEER FOR THE CAST-IN-PLACE AS SHOWN.
7. END BAR SHALL BE 2 1/2" x 3/8" x 1'-5 5/8"
8. CASTING FOR CATCH BASIN FRAME AND GRATES SHALL BE OF TOUGH GRAY IRON FREE FROM CRACKS, HOLES, SWELLS, AND COLD SHUTS.
9. REFER TO STANDARD PLAN NO. 20 FOR STORM DRAIN MARKER INSTALLATION.

DEVELOPMENT & ENGINEERING SERVICES DEPARTMENT  
 ENGINEERING SERVICES DIVISION CITY OF SALINAS

TITLE: <b>TYPE "A" CATCH BASIN</b>	
DESIGNED BY: STAFF	DATE: 10/21/2008
CADD BY: STAFF	<i>Robert C. Russell</i>
PROJECT MANAGER: FRANK A. AGUAYO, P.E.	ROBERT C. RUSSELL, CITY ENGINEER R.C.E. 42871, EXPIRES 3-31-2010

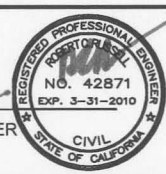

STANDARD PLAN  
**21**

**GENERAL NOTES**

1. DRAWING NOT TO SCALE.
2. CONNECTION PIPES MAY BE PLACED AT ANY POINT AROUND THE CATCH BASIN, PROVIDED THEY FLOW IN THE PROPER DIRECTION, AND THE PLACEMENT IS OTHERWISE CONSISTENT WITH THE IMPROVEMENT PLAN.
3. CURVATURES AT ALL OPENINGS OF THE CATCH BASIN SHALL BE FORMED WITH CURVED FORMS AND SHALL NOT BE MADE BY PLASTERING.
4. OUTLET PIPE SHALL BE TRIMMED TO FINAL LENGTH AND SHAPED BEFORE CONCRETE IS POURED.
5. ALL REINFORCING STEEL SHALL BE ADEQUATELY SUPPORTED TO MAINTAIN CORRECT POSITION DURING CONCRETE POUR.
6. ALL CONCRETE SHALL BE CLASS "2" P.C.C. PER THE CITY SPECIFICATIONS.
7. STEEL REINFORCING BARS SHALL BE #4 REBAR GRADE 60 CONFORMING TO ASTM A615 (MIN. COVER OF 1").
8. ANCHOR BARS AT ANGLE SHALL BE SHOP WELDED AND SHALL BE HOT-DIP GALVANIZED AFTER FABRICATION.
9. "V" = 3' PLUS O.D. OF PIPE UNLESS OTHERWISE SPECIFIED.
10. #6 PROTECTION REBAR (EMBED MINIMUM OF 4" INTO CONCRETE AT EACH END) GALVANIZED AFTER FABRICATION.
11. REFER TO STANDARD PLAN NO. 20 FOR STORM DRAIN MARKER INSTALLATION.

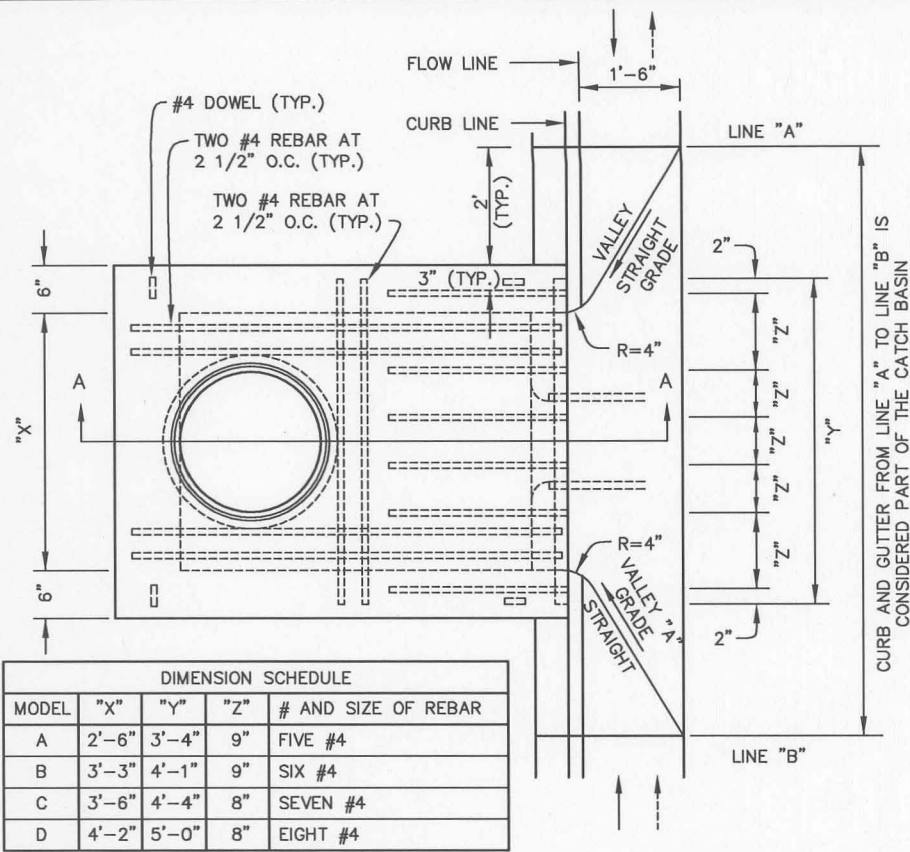

DIMENSION SCHEDULE				
MODEL	"X"	"Y"	"Z"	# AND SIZE OF REBAR
A	2'-6"	3'-4"	9"	FIVE #4
B	3'-3"	4'-1"	9"	SIX #4
C	3'-6"	4'-4"	8"	SEVEN #4
D	4'-2"	5'-0"	8"	EIGHT #4

DESIGN NOTE: GUTTER DEPRESSION  
 USE SOLID LINES FOR GRADE SAG  
 USE DASHED LINES AND VALLEY "A" FOR FLOW IN ONE DIRECTION ONLY

**PLAN**

CAST IRON FRAME AND COVER  
 PINKERTON A-335 (OR APPROVED  
 EQUAL BY THE CITY ENGINEER).  
 CLEAR OPENING = 24" AND  
 FRAME HEIGHT = 2"

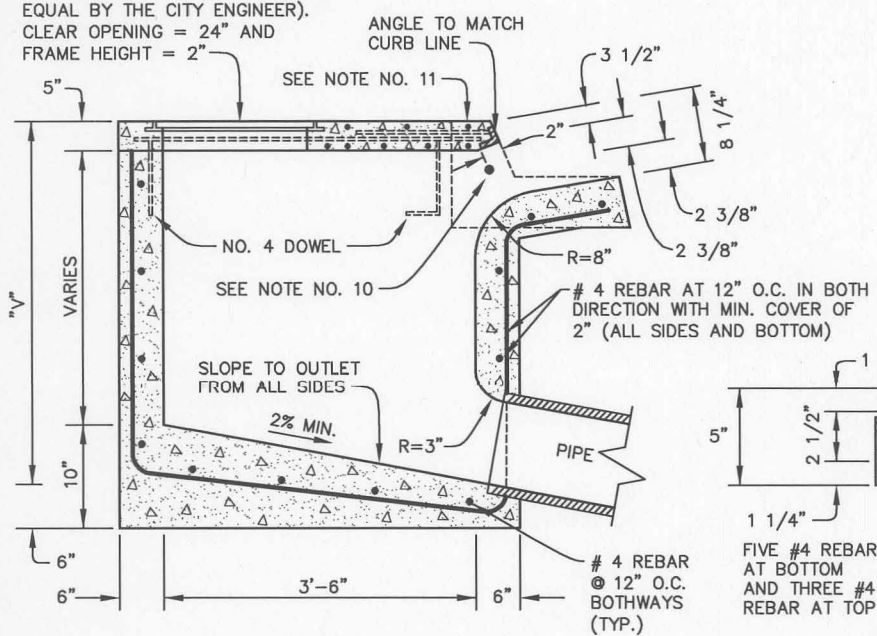

**SECTION A-A**

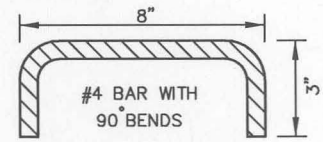

**DETAIL OF DOWEL**

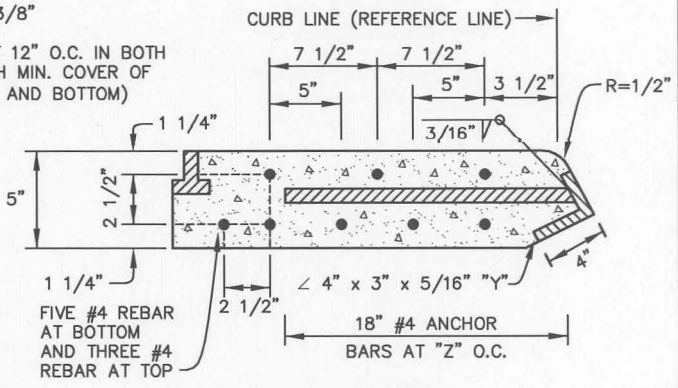

**DETAIL OF REINFORCEMENT**

**DEVELOPMENT & ENGINEERING SERVICES DEPARTMENT**  
 ENGINEERING SERVICES DIVISION CITY OF SALINAS

TITLE: **TYPE "D" SIDE OPENING CATCH BASIN**

DESIGNED BY: \_\_\_\_\_ DATE: 10/21/2008

STAFF: \_\_\_\_\_

CADD BY: \_\_\_\_\_

STAFF: \_\_\_\_\_

PROJECT MANAGER: \_\_\_\_\_

FRANK A. AGUAYO, P.E.

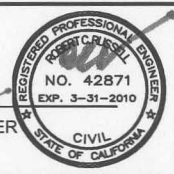

**STANDARD PLAN**

**22**



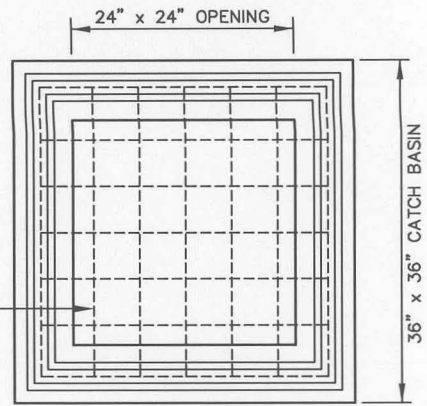
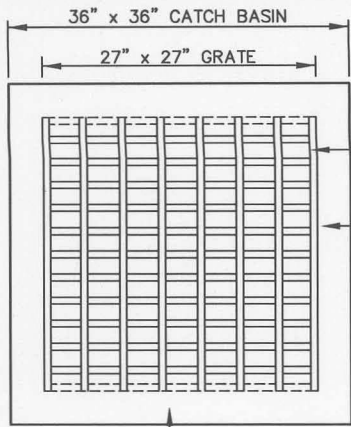

"NO DUMPING - DRAINS TO THE BAY" SHALL BE STENCILED ON TOP OF CATCH BASIN

**PLAN VIEW**

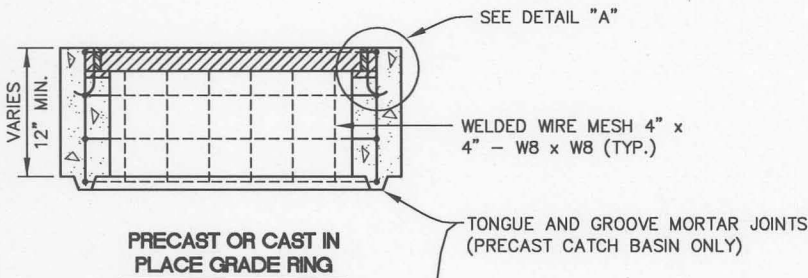

**CAST-IN-PLACE CATCH BASIN**  
POUR CONCRETE COLLAR AND INSTALL FRAME TO FINISH GRADE

**GRATE FRAME** SHALL BE MIN. 4" x 3" x 3/16" GALVANIZED ANGLE IRON WITH ANCHOR BOLTS EMBEDDED IN CONCRETE

**PRECAST CATCH BASIN** SHALL BE FURNISHED WITH CAST-IN GALVANIZED FRAME

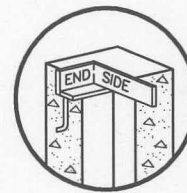

**DETAIL 'A'**

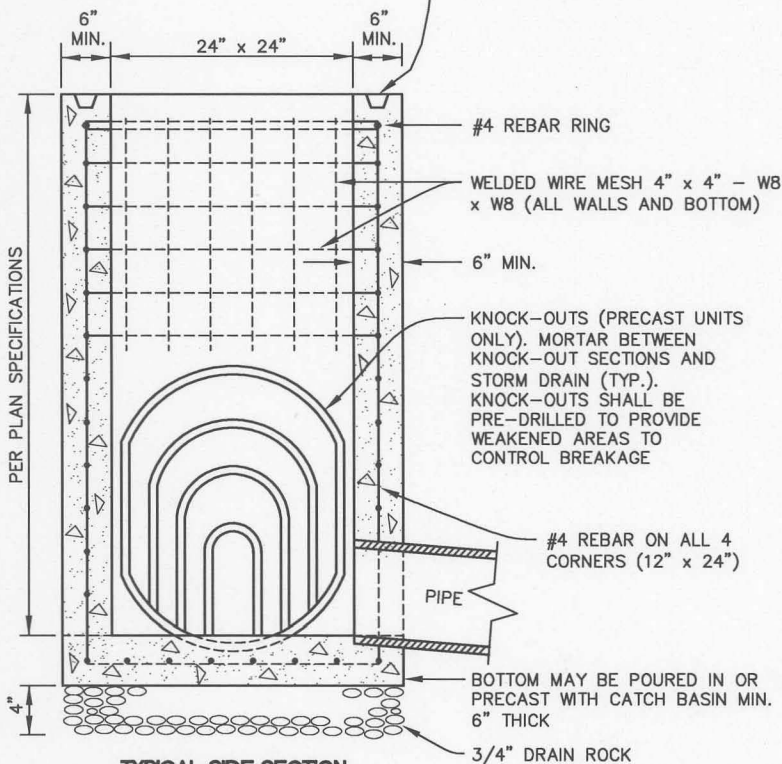

**GENERAL NOTES**

1. DRAWING NOT TO SCALE.
2. ALL CONCRETE SHALL BE CLASS "2" P.C.C. IN ACCORDANCE WITH THE CITY STANDARD SPECIFICATIONS.
3. CONTRACTOR MAY USE EITHER PRECAST OR CAST-IN-PLACE CONCRETE CATCH BASIN CONFORMING TO ALL THE REQUIREMENTS SHOWN HEREIN.
4. FRAME AND GRATE SHALL BE GALVANIZED IN ACCORDANCE WITH A.S.T.M. SPECIFICATIONS A123-59. GRATE SHALL BE HEAVY DUTY AND RATED FOR H-20 LOADING AND BICYCLE PROOF.
5. ALL CATCH BASIN WALLS AND BASE SHALL HAVE WELDED WIRE MESH 4" x 4" - W8 x W8. WIRE MESH SHALL BE CONTINUOUS AND LAP A MIN. OF 12" AT CORNERS.
6. CATCH BASINS LESS THAN 4' DEEP SHALL BE CONTINUOUS WITH NO GRADE RINGS.
7. CONTRACTOR SHALL MINIMIZE NUMBER OF GRADE RINGS REQUIRED.
8. PRECAST CATCH BASINS MAY BE ORDERED WITH OR WITHOUT BOTTOM.
9. APPROVED PRECAST CATCH BASINS INCLUDE CHRISTY U-21 WITH 71R GALVANIZED GRATE, SANTA ROSA K2 WITH HEAVY DUTY TYPE BICYCLE PROOF GRATE (OR APPROVED EQUAL BY THE CITY ENGINEER).

**DEVELOPMENT & ENGINEERING SERVICES DEPARTMENT**  
ENGINEERING SERVICES DIVISION CITY OF SALINAS

TITLE: **TYPE "E" TOP OPENING CATCH BASIN**

**STANDARD PLAN**

DESIGNED BY:  
STAFF

CADD BY:  
STAFF

PROJECT MANAGER:  
FRANK A. AGUAYO, P.E.

DATE 10/21/2008

*Robert C. Russell*

ROBERT C. RUSSELL, CITY ENGINEER  
R.C.E. 42871, EXPIRES 3-31-2010



**23**

DIMENSION TABLE		
DIM.	FLAT GRATE	TIDEWATER GRATE
"A"	2 1/2"	2 3/4" FOR 30" R.C.P. 2 5/8" FOR 27" R.C.P.
"B"	24" I.D. R.C.P.	27" FOR 30" I.D. R.C.P.

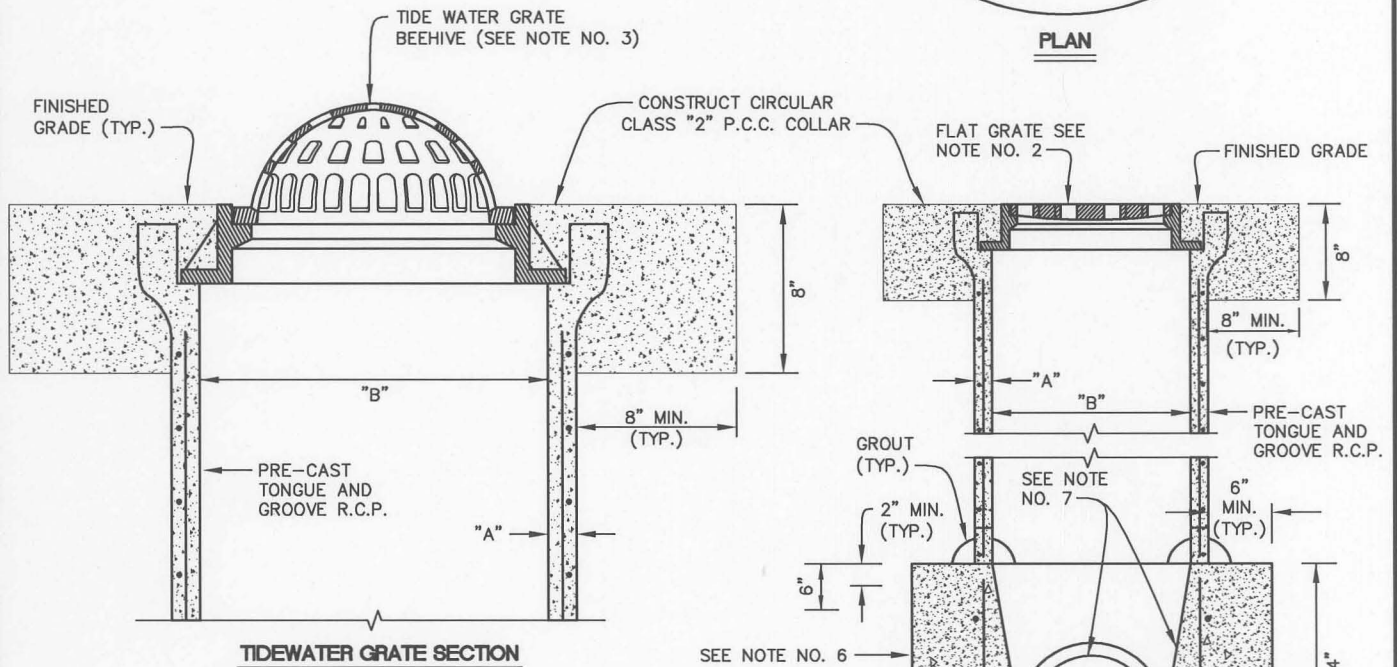
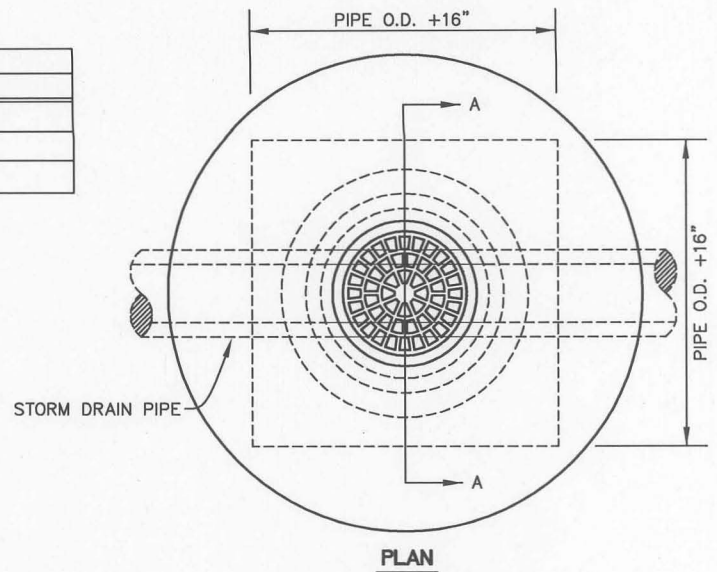

### GENERAL NOTES

1. DRAWING NOT TO SCALE.
2. TRAFFIC FRAME AND COVER SHALL BE NEENAH R-2510 OR ALHAMBRA A-1210 (OR APPROVED EQUAL BY THE CITY ENGINEER).
3. TIDEWATER GRATE SHALL BE NEENAH R-2560 OR ALHAMBRA A-1215 (OR APPROVED EQUAL BY THE CITY ENGINEER).
4. ALL FRAMES AND GRATES SHALL BE CAST IRON. ALL FRAME AND GRATE SIZES SHALL BE APPROVED BY CITY ENGINEER.
5. WHERE APPLICABLE AND UPON APPROVAL BY CITY ENGINEER, THE FLAT GRATE R.C.P. CATCH BASIN MAY BE SUBSTITUTED WITH A CALTRANS TYPE G1 INLET (REFER TO CALTRANS STANDARD PLAN D-73 FOR DESIGN SPECIFICATIONS).
6. P.C.C. SHALL BE CLASS "2". CONSTRUCT PER SECTION 51 OF THE CITY STANDARD SPECIFICATIONS.
7. BREAKOUT PIPE ACROSS INLET AND SLOPE TO SOFFIT.

## DEVELOPMENT & ENGINEERING SERVICES DEPARTMENT

ENGINEERING SERVICES DIVISION

CITY OF SALINAS

TITLE: **TYPE "F" CATCH BASIN**

STANDARD PLAN

DESIGNED BY:  
STAFF

DATE 10/21/2008

CADD BY:  
STAFF

*Robert C. Russell*

PROJECT MANAGER:  
FRANK A. AGUAYO, P.E.

ROBERT C. RUSSELL, CITY ENGINEER  
R.C.E. 42871, EXPIRES 3-31-2010

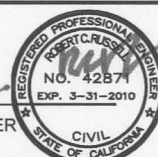

**24**

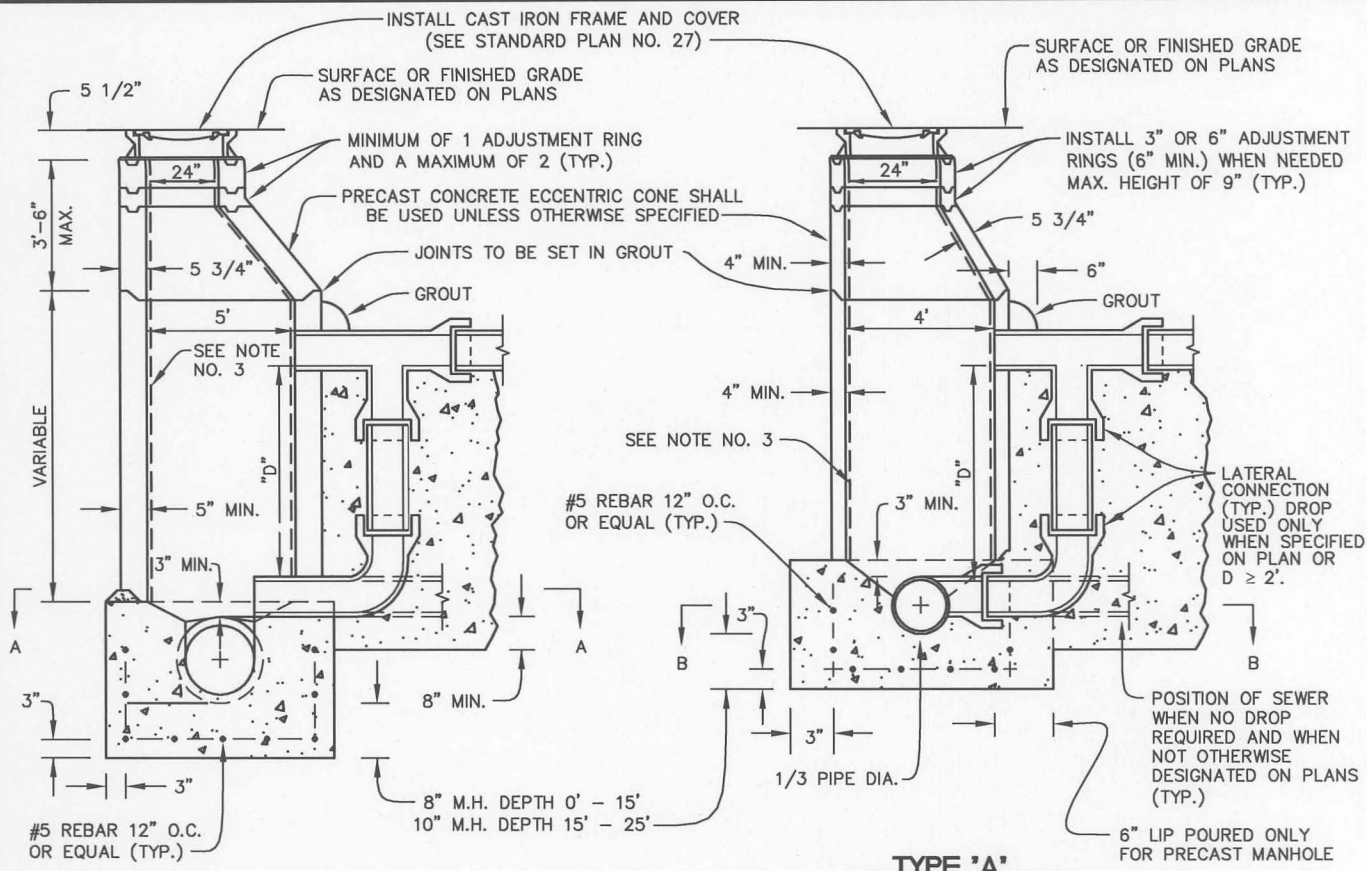

**TYPE 'B'**  
(FOR PIPES OVER 36")

**TYPE 'A'**  
(FOR PIPES UNDER 36")

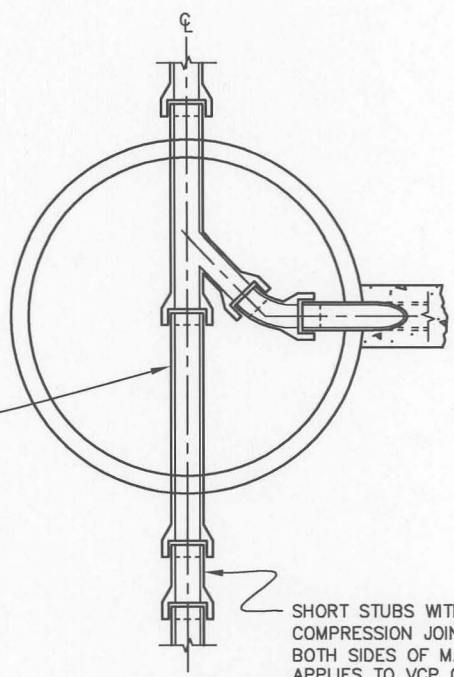
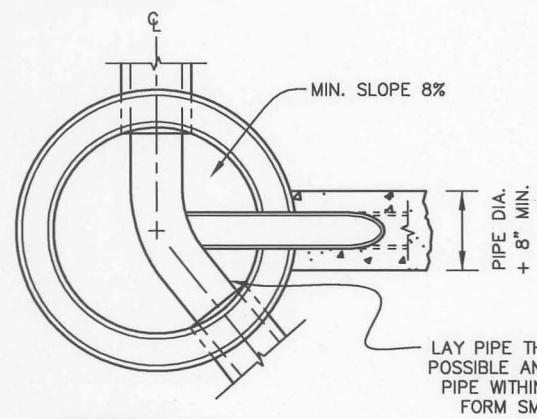

**SECTION A-A**  
**GENERAL NOTES**

1. DRAWING NOT TO SCALE.
2. CONSTRUCT CLASS "2" P.C.C. PER SECTION 51 OF THE CITY STANDARD SPECIFICATIONS.
3. FOR SANITARY SEWER MANHOLES PROVIDE FIBERGLASS LINER WITH UNITED COATINGS ELASTUFF 120, ELASTUFF 120 HYDROPHOBIC POLYURETHANE ELASTOMER WITH UNI-TILE SEALER, RAVEN 405 100% SOLID EPOXY (OR APPROVED EQUAL BY CITY ENGINEER).
4. AVERAGE THICKNESS OF LINER SHALL BE 180 MIL. WITH A MINIMUM OF 150 MIL.

DEVELOPMENT & ENGINEERING SERVICES DEPARTMENT  
ENGINEERING SERVICES DIVISION CITY OF SALINAS

TITLE: <b>TYPE "A" AND "B" MANHOLE</b>	
DESIGNED BY: STAFF	DATE 10/21/2008
CADD BY: STAFF	<i>Robert Russell</i>
PROJECT MANAGER: FRANK A. AGUAYO, P.E.	ROBERT C. RUSSELL, CITY ENGINEER R.C.E. 42871, EXPIRES 3-31-2010

STANDARD PLAN

**25**

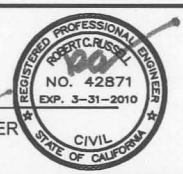

**GENERAL NOTES**

1. DRAWING NOT TO SCALE.
2. THIS MANHOLE SHALL BE USED IN LOCATIONS WHEN COVER IS LESS THAN 30".
3. CONSTRUCT CLASS "2" P.C.C. PER SECTION 51 OF THE CITY STANDARD SPECIFICATIONS.

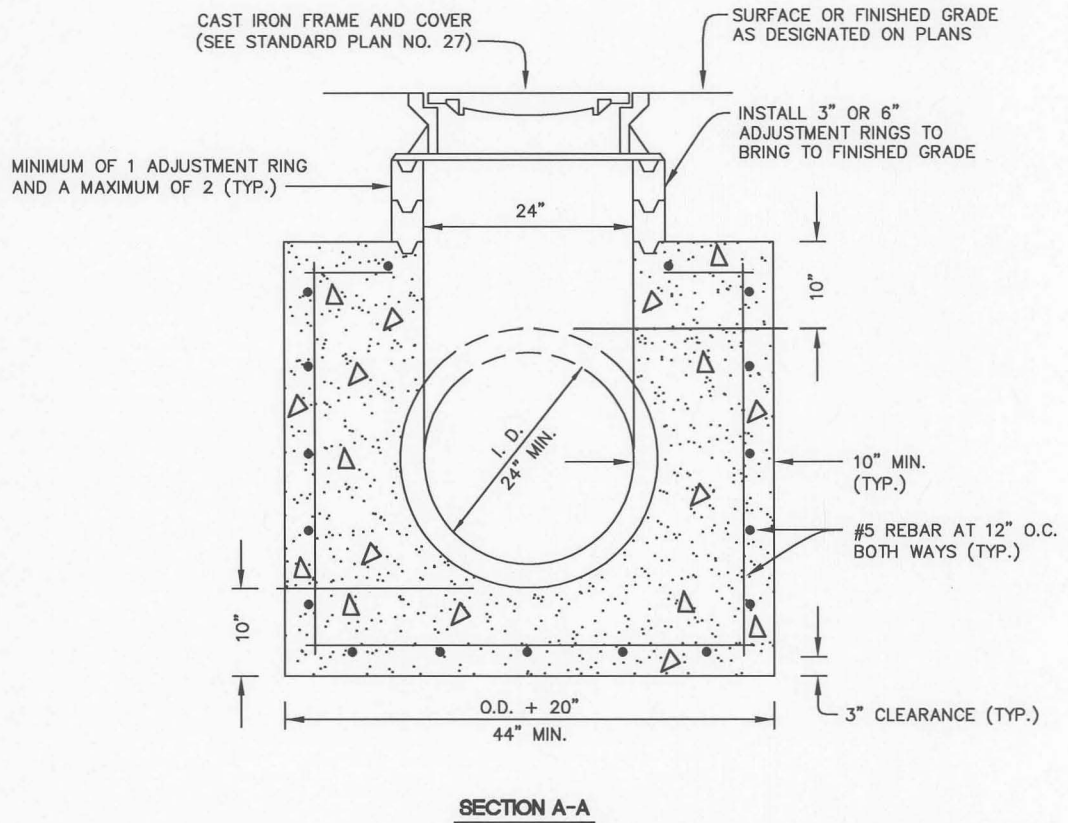
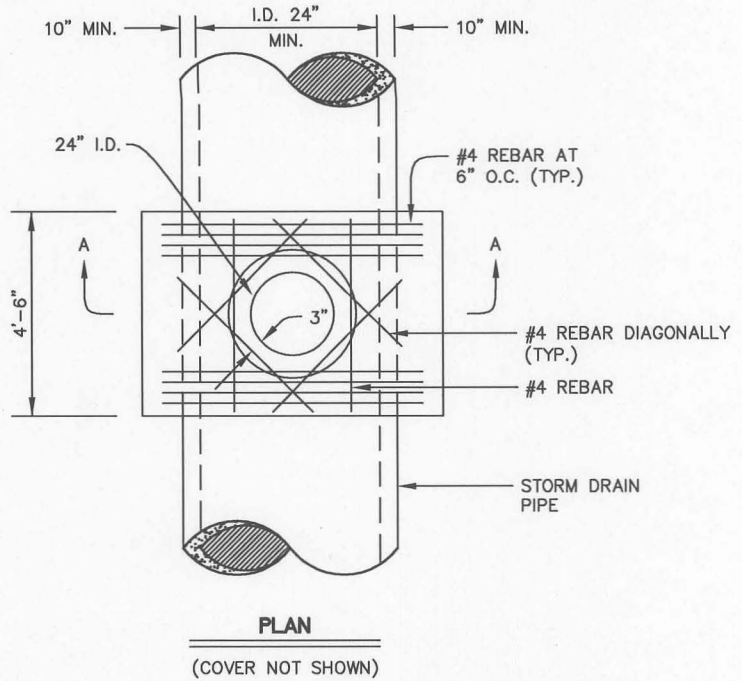

<b>DEVELOPMENT &amp; ENGINEERING SERVICES DEPARTMENT</b>		CITY OF SALINAS
ENGINEERING SERVICES DIVISION		
TITLE: <b>TYPE "C" MANHOLE (SHALLOW TYPE)</b>		<b>STANDARD PLAN</b>
DESIGNED BY: STAFF	DATE: 10/21/2008	<b>26</b>
CADD BY: STAFF	<i>Robert Russell</i>	
PROJECT MANAGER: FRANK A. AGUAYO, P.E.	ROBERT C. RUSSELL, CITY ENGINEER R.C.E. 42871, EXPIRES 3-31-2010	





PICKHOLE (SEE PICKHOLE DETAIL)

SKID RESISTANT PER ASTM NO. 362-1962

"S" OR "SANITARY SEWER"  
"D" OR "STORM DRAIN"  
"I" OR "INDUSTRIAL WASTE"  
TO BE CAST ON TOP OF MANHOLE COVER

SIDE PRY HOLE

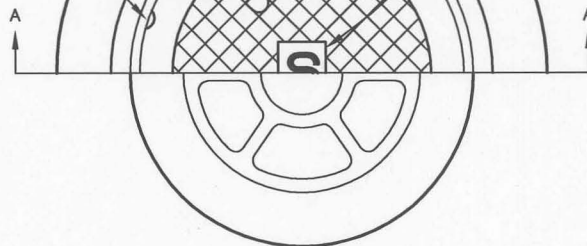

PLAN

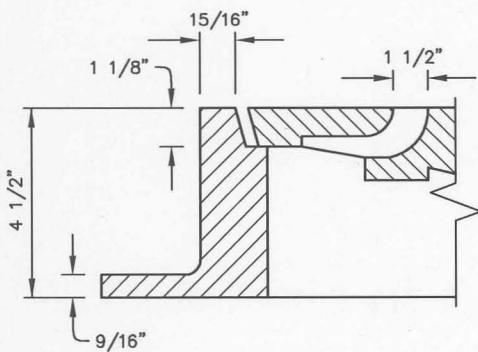

PICKHOLE DETAIL

MACHINED SURFACES

10 1/2" TAPER

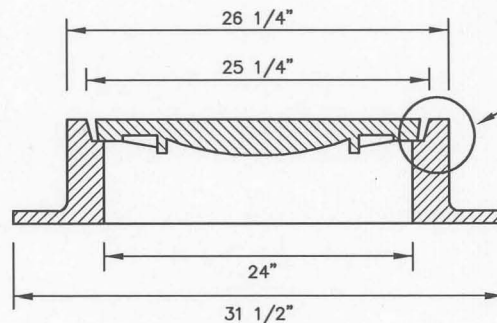

SECTION A-A

GENERAL NOTES

1. DRAWING NOT TO SCALE.
2. BEARING SURFACES OF FRAME AND COVER SHALL BE MACHINED TO FIT WITH POSITIVE PRESSURE ON ALL SURFACES.
3. MINIMUM WEIGHT FOR RING AND COVER SHALL BE 265 POUNDS.
4. MANHOLE FRAME AND COVER SPECIFICATIONS NOT APPLICABLE TO UTILITIES.
5. ALL MATERIALS USED IN MANUFACTURING FRAME AND COVER SHALL CONFORM TO ASTM A-159-70T-G3000 OR U.S. GOVERNMENT SPECIFICATION QQ I-653.
6. ENTIRE FRAME AND COVER ASSEMBLY SHALL BE CAPABLE OF SUPPORTING H-20 HIGHWAY LOADING.
7. LID SHALL HAVE TWO PICKHOLES. CONTRACTOR SHALL DRILL EXTRA IF NOT PROVIDED BY MANUFACTURER.

**DEVELOPMENT & ENGINEERING SERVICES DEPARTMENT**

ENGINEERING SERVICES DIVISION

CITY OF SALINAS

TITLE: **MANHOLE FRAME AND COVER**

**STANDARD PLAN**

DESIGNED BY:  
STAFF

DATE 10/21/2008

CADD BY:  
STAFF

*Robert C. Russell*

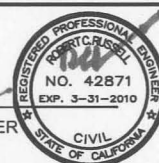

PROJECT MANAGER:  
**FRANK A. AGUAYO, P.E.**

ROBERT C. RUSSELL, CITY ENGINEER  
R.C.E. 42871, EXPIRES 3-31-2010

**27**

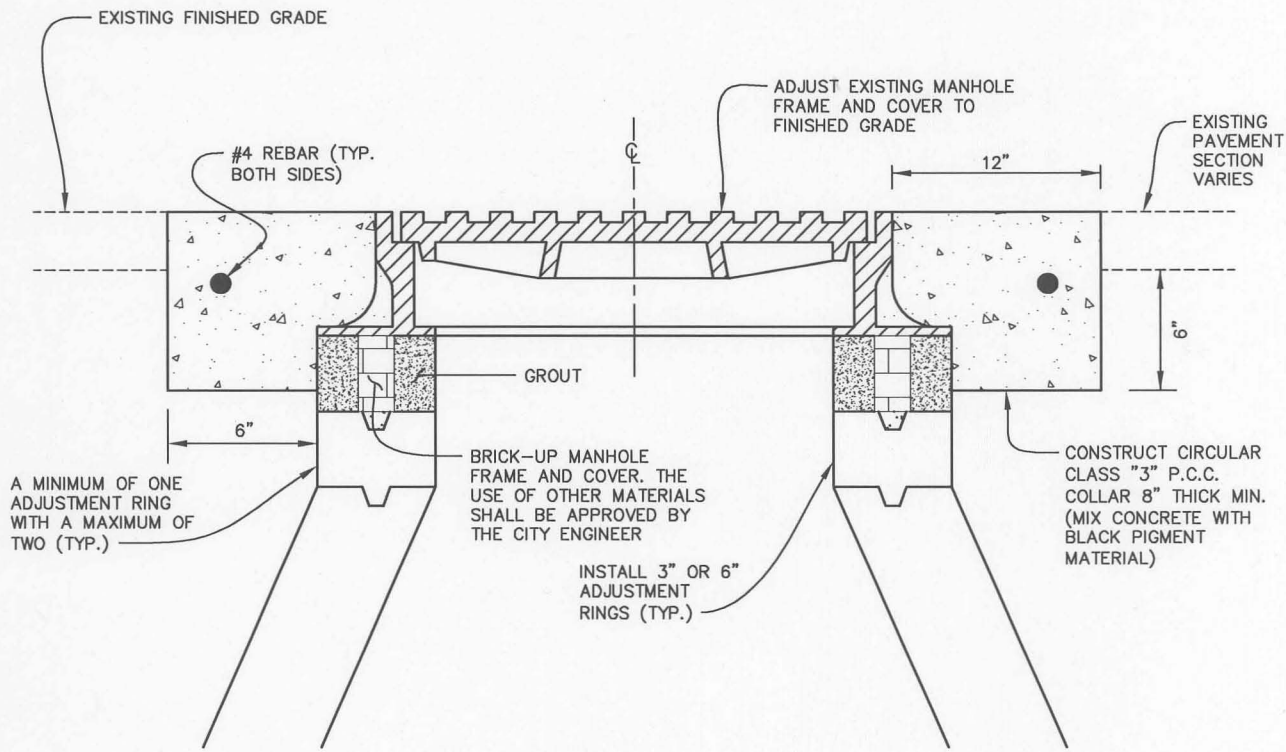

**GENERAL NOTES**

1. DRAWING NOT TO SCALE.
2. CONSTRUCT CLASS "3" P.C.C. PER SECTION 51 OF THE CITY STANDARD SPECIFICATIONS.

**DEVELOPMENT & ENGINEERING SERVICES DEPARTMENT**  
 ENGINEERING SERVICES DIVISION CITY OF SALINAS

**TITLE: MANHOLE FRAME AND COVER ADJUSTMENT**

**STANDARD PLAN**  
  
**28**

DESIGNED BY:  
STAFF

CADD BY:  
STAFF

PROJECT MANAGER:  
FRANK A. AGUAYO, P.E.

DATE 10/21/2008

*Robert C. Russell*

ROBERT C. RUSSELL, CITY ENGINEER  
R.C.E. 42871, EXPIRES 3-31-2010



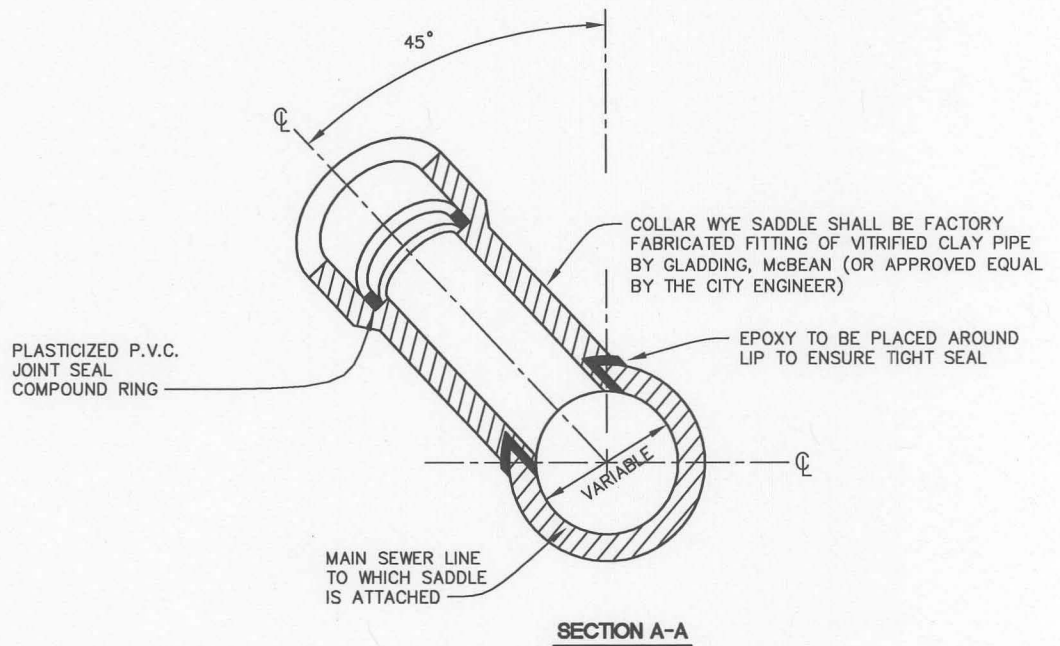
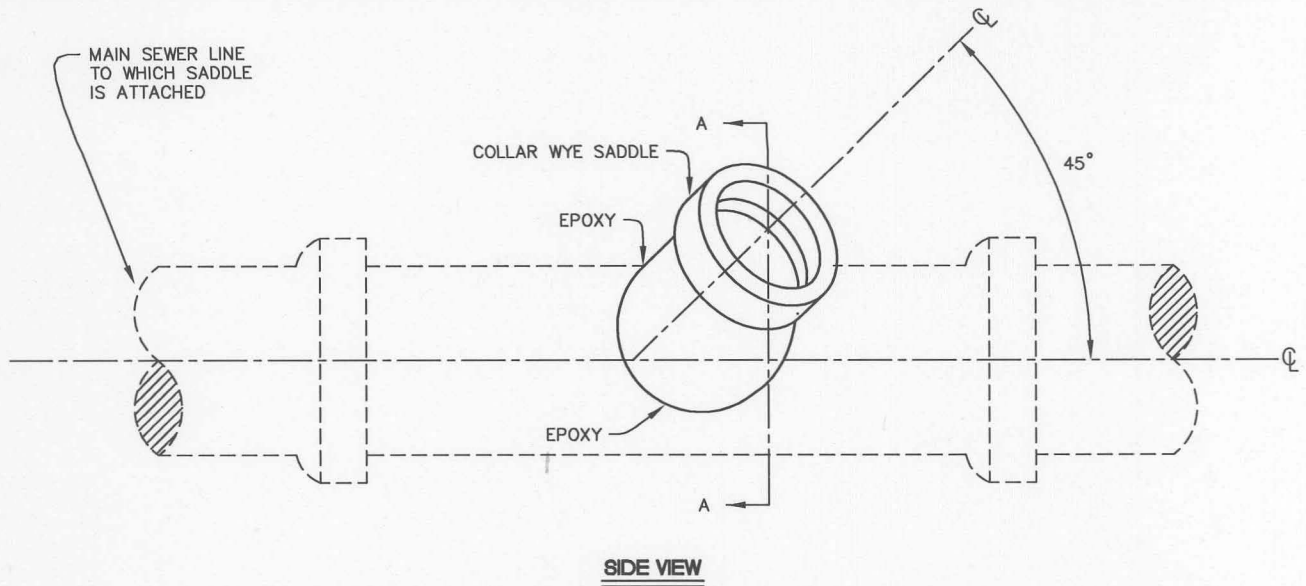

**GENERAL NOTES**

1. DRAWING NOT TO SCALE.
2. MAIN SEWER SHALL NOT BE SADDLED WHEN THE DIFFERENCE IN DIAMETER BETWEEN THE MAIN AND THE LATERAL IS LESS THAN 4".
3. NO SEWER SHALL BE SADDLED UNLESS THE CUT INTO THE MAIN IS MADE WITH A CORE DRILL WHICH CUTS A ROUND HOLE AND A COLLARED WYE IS FASTENED TO PIPE WITH EPOXY.
4. NO SEWER SHALL BE SADDLED WITHOUT PRIOR APPROVAL OF THE CITY ENGINEER.
5. ALL SADDLES SHALL BE APPROVED BY THE CITY ENGINEER BEFORE BACKFILLING.

<b>DEVELOPMENT &amp; ENGINEERING SERVICES DEPARTMENT</b>		CITY OF SALINAS
ENGINEERING SERVICES DIVISION		
<b>TITLE: SEWER SADDLE CONNECTION</b>		<b>STANDARD PLAN</b>
DESIGNED BY: STAFF	DATE <u>10/21/2008</u>	<b>29</b>
CADD BY: STAFF	<i>Robert Russell</i>	
PROJECT MANAGER: FRANK A. AGUAYO, P.E.	ROBERT C. RUSSELL, CITY ENGINEER R.C.E. 42871, EXPIRES 3-31-2010	

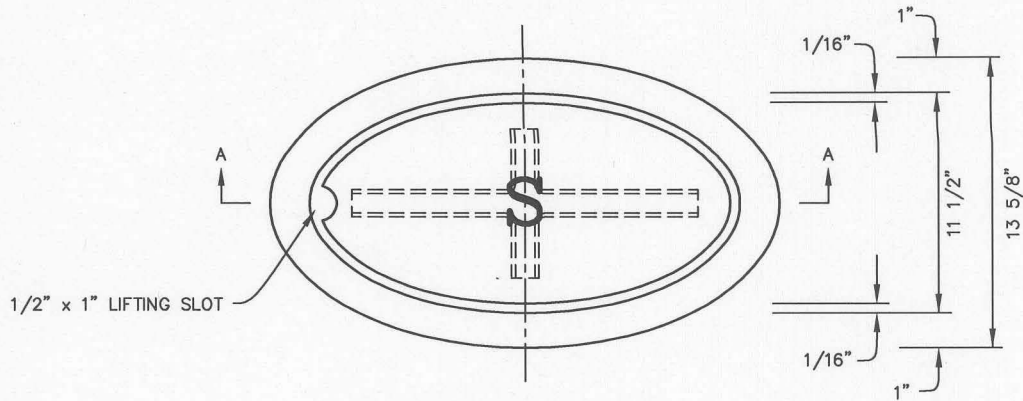

**PLAN OF COVER AND FRAME**

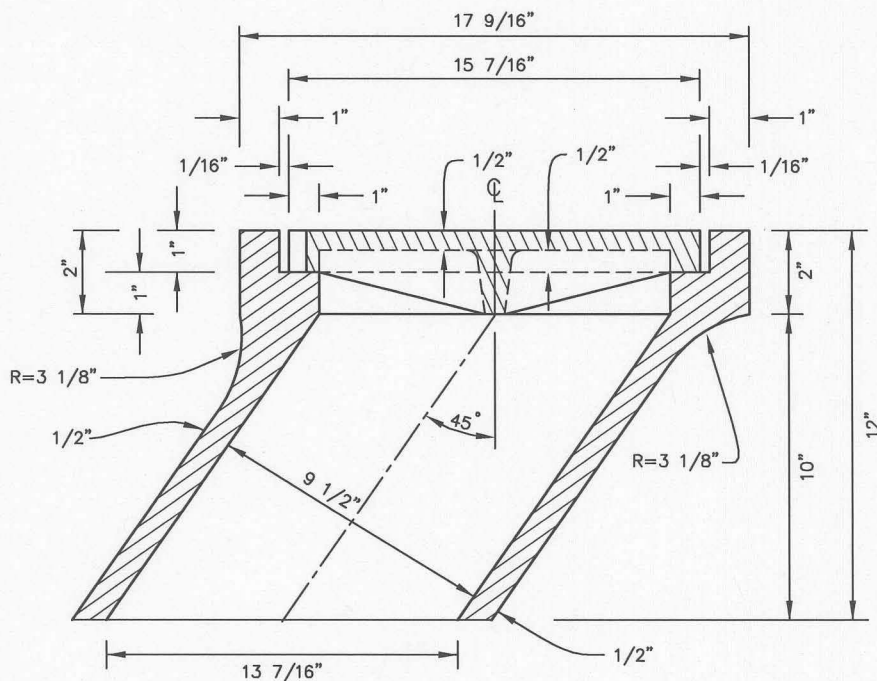

**SECTION A-A  
RISER, FRAME, AND COVER**

**GENERAL NOTES**

1. DRAWING NOT TO SCALE.
2. BEARING SURFACES OF FRAME AND COVER SHALL BE GROUND TO FIT WITH POSITIVE PRESSURE ON ALL SURFACES.
3. FRAME AND COVER SHALL BE PINKERTON A-211 (OR APPROVED EQUAL BY THE CITY ENGINEER).
4. FRAME AND COVER SHALL HAVE A MINIMUM WEIGHT OF 125 LBS.

**DEVELOPMENT & ENGINEERING SERVICES DEPARTMENT**  
ENGINEERING SERVICES DIVISION CITY OF SALINAS

**TITLE: FLUSHING INLET FRAME AND COVER**

**STANDARD PLAN**

DESIGNED BY:  
STAFF

CADD BY:  
STAFF

PROJECT MANAGER:  
FRANK A. AGUAYO, P.E.

DATE 10/21/2008

*Robert C. Russell*

ROBERT C. RUSSELL, CITY ENGINEER  
R.C.E. 42871, EXPIRES 3-31-2010



**30**



**GENERAL NOTES**

1. DRAWING NOT TO SCALE.
2. PIPE NOT TO BE MADE RIGID WITH CASTING.
3. MORTAR: 1-PART CEMENT AND 5-PART SAND, OR C.P.I. 2.
4. SEE CITY STANDARD PLAN NO. 30 FOR DETAILS OF RISER, FRAME, AND COVER.
5. CONCRETE SHALL BE CLASS "3" PER CITY STANDARD SPECIFICATIONS. MIX CONCRETE WITH BLACK PIGMENT MATERIAL.
6. FOR PLASTIC PIPE (P.V.C., H.D.P.E., ETC.) A DETAIL FOR FLUSHING INLET SHALL BE SUBMITTED TO THE CITY ENGINEER FOR APPROVAL.

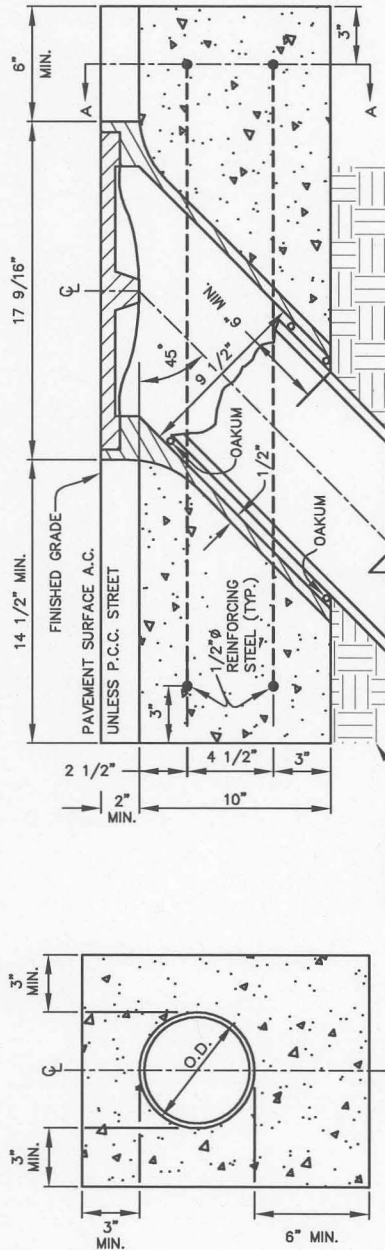

**SECTION B-B**

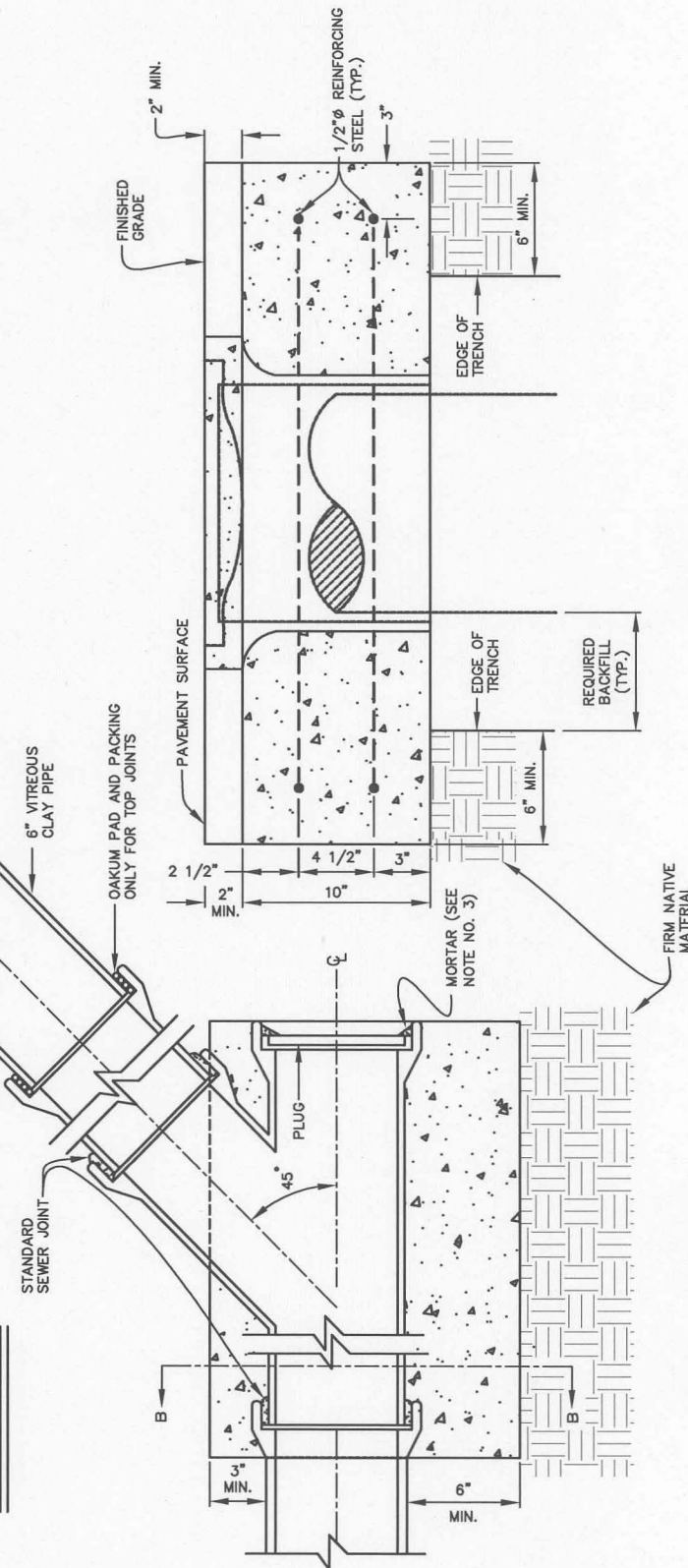

**SECTION A-A**

**VERTICAL SECTION**

**DEVELOPMENT & ENGINEERING SERVICES DEPARTMENT**  
 ENGINEERING SERVICES DIVISION CITY OF SALINAS

<b>TITLE: FLUSHING INLET</b>	
DESIGNED BY: STAFF	DATE <u>10/21/2008</u>
CADD BY: STAFF	<i>Robert Russell</i>
PROJECT MANAGER: FRANK A. AGUAYO, P.E.	ROBERT C. RUSSELL, CITY ENGINEER R.C.E. 42871, EXPIRES 3-31-2010



STANDARD PLAN

31

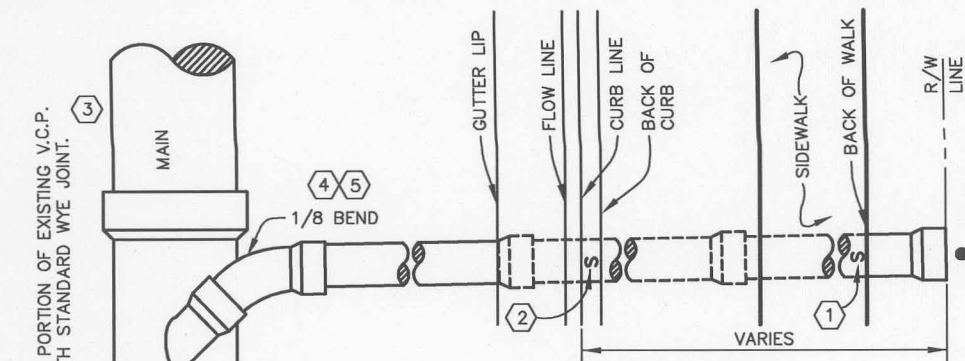

V.C. STOPPER AND SEAL INSTALL #4 x 30" LONG REINFORCING REBAR REQUIRED IF HOUSE CONNECTION IS NOT MADE AT TIME OF LATERAL CONSTRUCTION

**PLAN**  
NOT TO SCALE

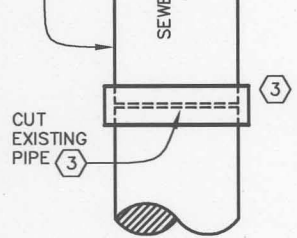

- 1 THE LOCATION OF ALL SEWER LATERALS SHALL BE MARKED WITH A LETTER "S" ON TOP OF CURB OR BACK OF WALK. WHERE SIDEWALK EXISTS OR IS TO BE CONSTRUCTED LETTER "S" SHALL BE CHISELED OR STAMPED ON CONCRETE NEAR BACK OF SIDEWALK OVER LATERAL CROSSING. LETTER SHALL BE NOT LESS THAN 3" HIGH, 2" WIDE, 3/16" DEEP.
- 2 WHERE ONLY CURB AND GUTTER EXISTS OR TO BE CONSTRUCTED THE LETTER "S" SHALL BE CHISELED OR STAMPED ON TOP OF CURB OVER LATERAL CROSSING. IF LATERAL CROSSES UNDER DRIVEWAYS LETTER "S" SHALL BE PUT ON TOP OF DEPRESSED CURB OR NEAR BACK OF DRIVEWAY.
- 3 REPLACE PORTION OF EXISTING V.C.P. WITH A NEW WYE JOINT AND JOIN WITH AN APPROVED FLEXIBLE COMPRESSION JOINT, MISSION CLAY PRODUCTS CORP. BAND-SEAL OR PACIFIC CLAY PRODUCTS WEDGE-LOCK (OR APPROVED EQUAL BY THE CITY ENGINEER), WHERE NO WYE EXISTS IN MAIN.

NOTE: FOR PLASTIC PIPE (P.V.C., H.D.P.E., ETC.), THE CONTRACTOR SHALL SUBMIT DETAIL FOR SEWER LATERAL CONNECTION FOR CITY ENGINEER'S APPROVAL.

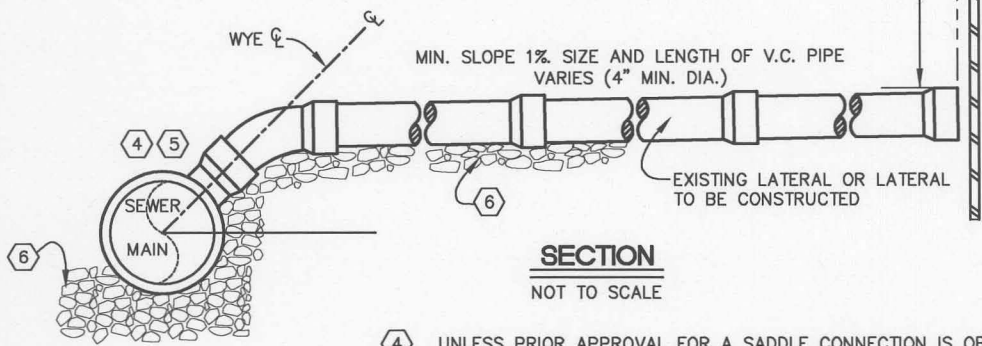
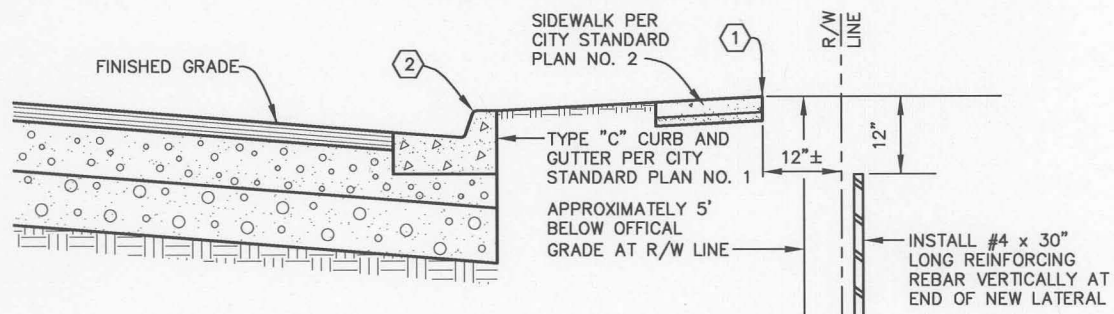

**SECTION**  
NOT TO SCALE

- 4 UNLESS PRIOR APPROVAL FOR A SADDLE CONNECTION IS OBTAINED FROM THE CITY ENGINEER, LATERAL CONNECTION INTO MAIN SEWER SHALL BE MADE AT A WYE FITTING AS DETAILED ABOVE (REFER TO CITY STANDARD PLAN NO. 29).
- 5 MANHOLE IS REQUIRED AT THE JUNCTION OF AN EXISTING SEWER MAIN AND A NEW LATERAL IF THE LATERAL IS 8" OR LARGER, OR IF THE DIFFERENCE IN DIAMETER IS LESS THAN 4".
- 6 PIPE BEDDING PER CITY STANDARD PLAN NO. 16.

<b>DEVELOPMENT &amp; ENGINEERING SERVICES DEPARTMENT</b>		CITY OF SALINAS
ENGINEERING SERVICES DIVISION		
<b>TITLE: SEWER LATERAL (V.C.P.)</b>		<b>STANDARD PLAN</b>
DESIGNED BY: STAFF	DATE: 10/21/2008	<b>32</b>
CADD BY: STAFF	<i>Robert C. Russell</i>	
PROJECT MANAGER: FRANK A. AGUAYO, P.E.	ROBERT C. RUSSELL, CITY ENGINEER R.C.E. 42871, EXPIRES 3-31-2010	

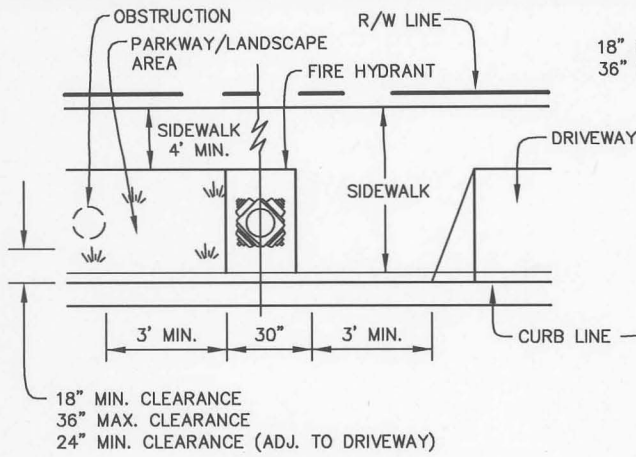

**CASE A:**

IN PARKWAY STRIP OR SIDEWALK

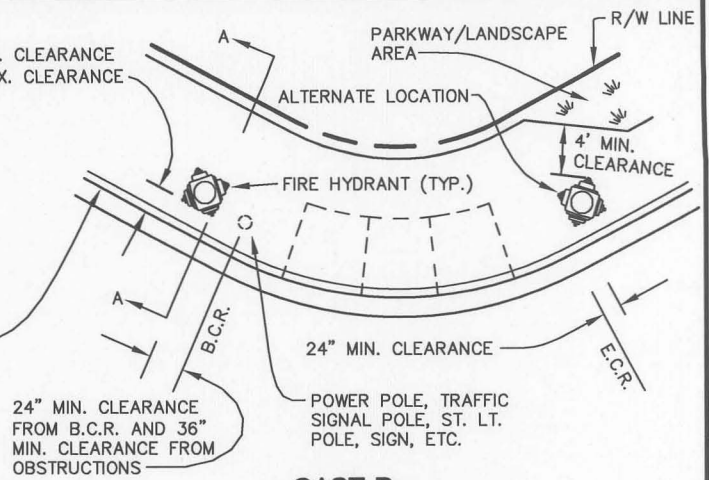

**CASE B:**

IN SIDEWALK AT CURB RETURN

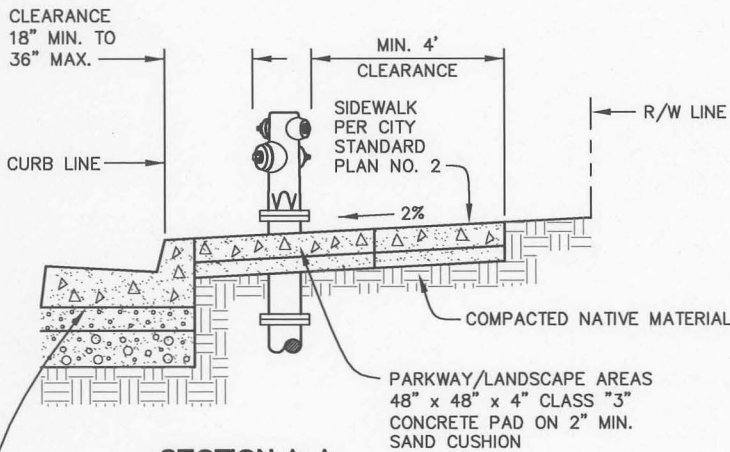

**SECTION A-A**

AT CURB RETURN AND MID BLOCK

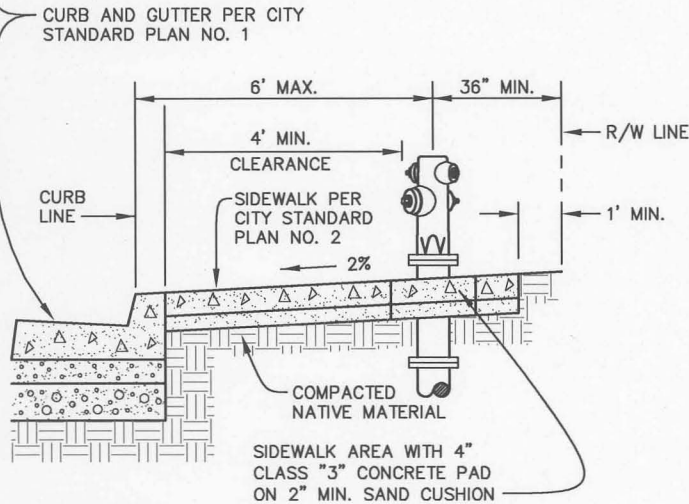

**SECTION B-B**

ALTERNATE LOCATION

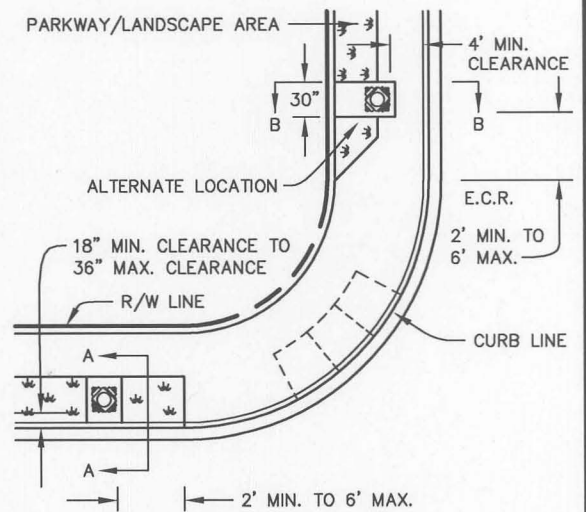

**CASE C:**

IN PARKWAY/PLANTER AT CURB RETURN

**GENERAL NOTES**

1. DRAWING NOT TO SCALE.
2. SIDEWALKS ADJACENT TO FIRE HYDRANT LOCATIONS SHALL BE A MINIMUM 4' WIDE (CLEARANCE) FOR PEDESTRIAN TRAFFIC.
3. DETAILS SHOW PREFERRED HYDRANT LOCATIONS. NO DIMENSIONS OR DETAIL HEREON SHALL PRECLUDE THE FINAL LOCATION OF FIRE HYDRANT IN THE FIELD BY THE SALINAS FIRE DEPARTMENT.
4. SEE CITY STANDARD PLAN NO. 34 FOR FIRE HYDRANT CONSTRUCTION AND OUTLET POSITION.
5. LOCATION AND QUANTITY OF BLUE RAISED PAVEMENT MARKERS (TYPE BB RPM) SHALL BE PER CITY STANDARD PLAN NO. 38 AND AS REQUIRED BY THE SALINAS FIRE DEPARTMENT.

DEVELOPMENT & ENGINEERING SERVICES DEPARTMENT  
 ENGINEERING SERVICES DIVISION  
 CITY OF SALINAS

TITLE: <b>FIRE HYDRANT LOCATION</b>		STANDARD PLAN	
DESIGNED BY: STAFF	DATE: 10/21/2008	REVIEWED BY: <i>M. Latham</i> for	<b>33</b>
CADD BY: STAFF	<i>Robert C. Russell</i>	FIRE CHIEF SALINAS FIRE DEPT.	
PROJECT MANAGER: FRANK A. AGUAYO, P.E.	ROBERT C. RUSSELL, CITY ENGINEER R.C.E. 42871, EXPIRES 3-31-2010		



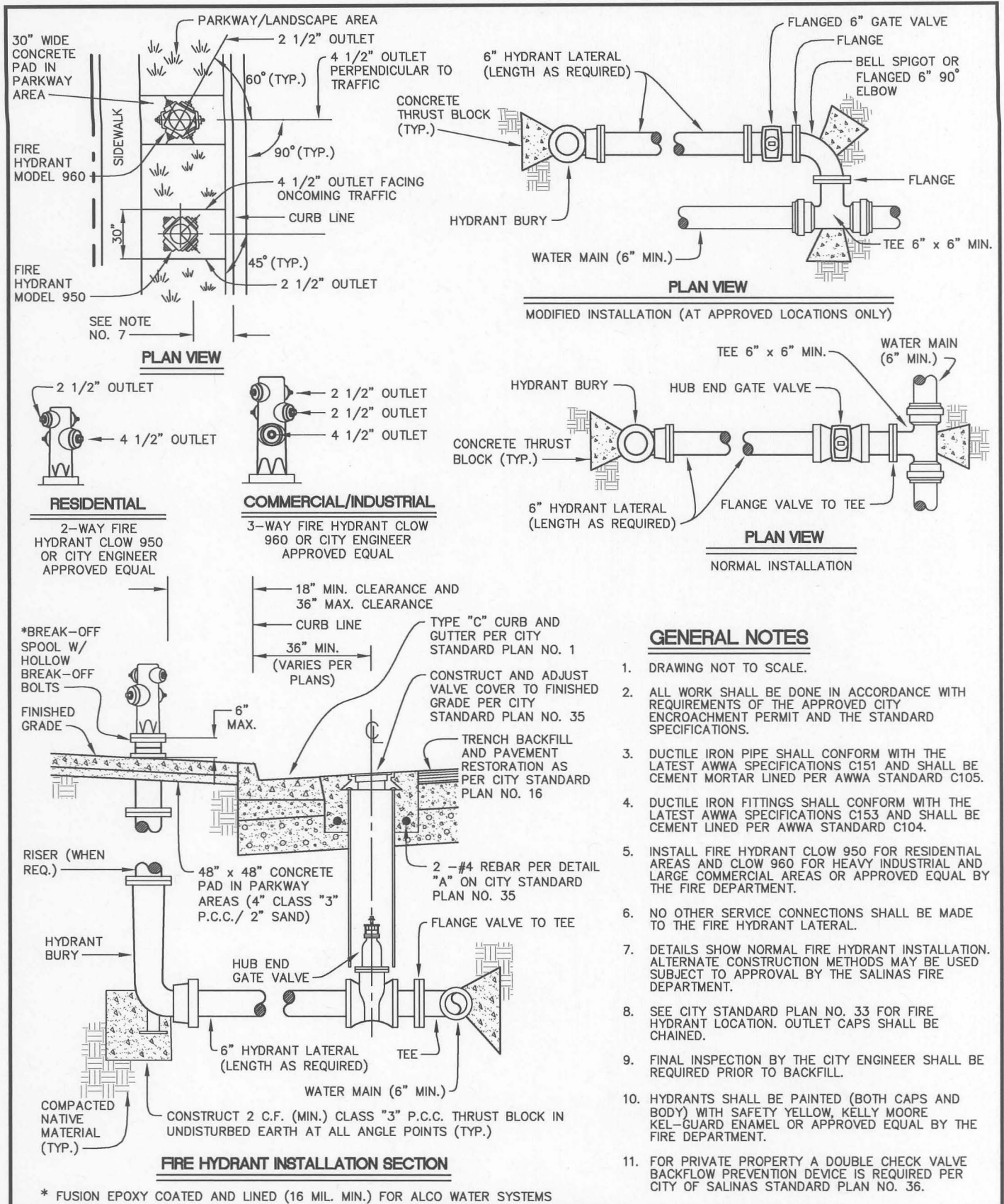

**GENERAL NOTES**

1. DRAWING NOT TO SCALE.
2. ALL WORK SHALL BE DONE IN ACCORDANCE WITH REQUIREMENTS OF THE APPROVED CITY ENCROACHMENT PERMIT AND THE STANDARD SPECIFICATIONS.
3. DUCTILE IRON PIPE SHALL CONFORM WITH THE LATEST AWWA SPECIFICATIONS C151 AND SHALL BE CEMENT MORTAR LINED PER AWWA STANDARD C105.
4. DUCTILE IRON FITTINGS SHALL CONFORM WITH THE LATEST AWWA SPECIFICATIONS C153 AND SHALL BE CEMENT LINED PER AWWA STANDARD C104.
5. INSTALL FIRE HYDRANT CLOW 950 FOR RESIDENTIAL AREAS AND CLOW 960 FOR HEAVY INDUSTRIAL AND LARGE COMMERCIAL AREAS OR APPROVED EQUAL BY THE FIRE DEPARTMENT.
6. NO OTHER SERVICE CONNECTIONS SHALL BE MADE TO THE FIRE HYDRANT LATERAL.
7. DETAILS SHOW NORMAL FIRE HYDRANT INSTALLATION. ALTERNATE CONSTRUCTION METHODS MAY BE USED SUBJECT TO APPROVAL BY THE SALINAS FIRE DEPARTMENT.
8. SEE CITY STANDARD PLAN NO. 33 FOR FIRE HYDRANT LOCATION. OUTLET CAPS SHALL BE CHAINED.
9. FINAL INSPECTION BY THE CITY ENGINEER SHALL BE REQUIRED PRIOR TO BACKFILL.
10. HYDRANTS SHALL BE PAINTED (BOTH CAPS AND BODY) WITH SAFETY YELLOW, KELLY MOORE KEL-GUARD ENAMEL OR APPROVED EQUAL BY THE FIRE DEPARTMENT.
11. FOR PRIVATE PROPERTY A DOUBLE CHECK VALVE BACKFLOW PREVENTION DEVICE IS REQUIRED PER CITY OF SALINAS STANDARD PLAN NO. 36.

**DEVELOPMENT & ENGINEERING SERVICES DEPARTMENT**

ENGINEERING SERVICES DIVISION CITY OF SALINAS

<b>TITLE: FIRE HYDRANT CONSTRUCTION</b>		<b>STANDARD PLAN</b>
DESIGNED BY: STAFF	DATE: 10/21/2008	<b>34</b>
CADD BY: STAFF	<i>Robert C. Russell</i>	
PROJECT MANAGER: FRANK A. AGUAYO, P.E.	ROBERT C. RUSSELL, CITY ENGINEER R.C.E. 42871, EXPIRES 3-31-2010	
		REVIEWED BY: <i>M. Fathon</i> for FIRE CHIEF SALINAS FIRE DEPT.



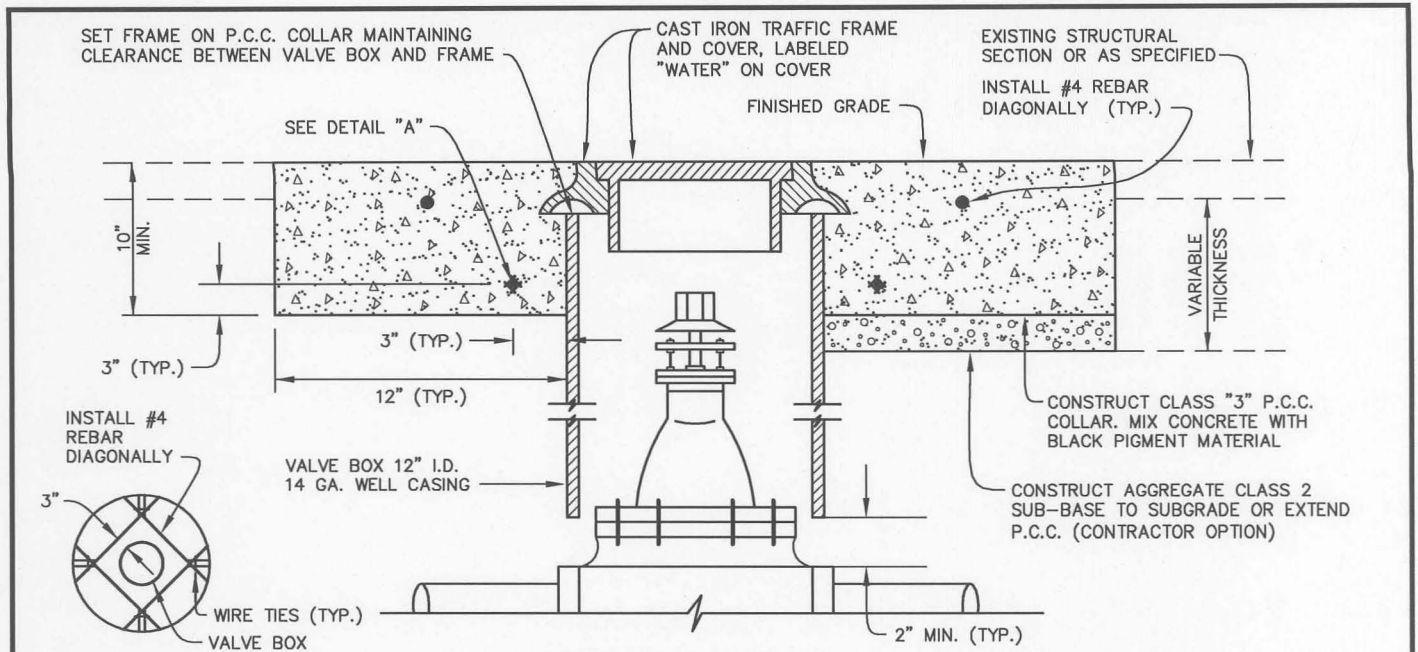

**DETAIL 'A'**

REINFORCED STEEL PLAN



**STEEL VALVE BOX DETAIL**

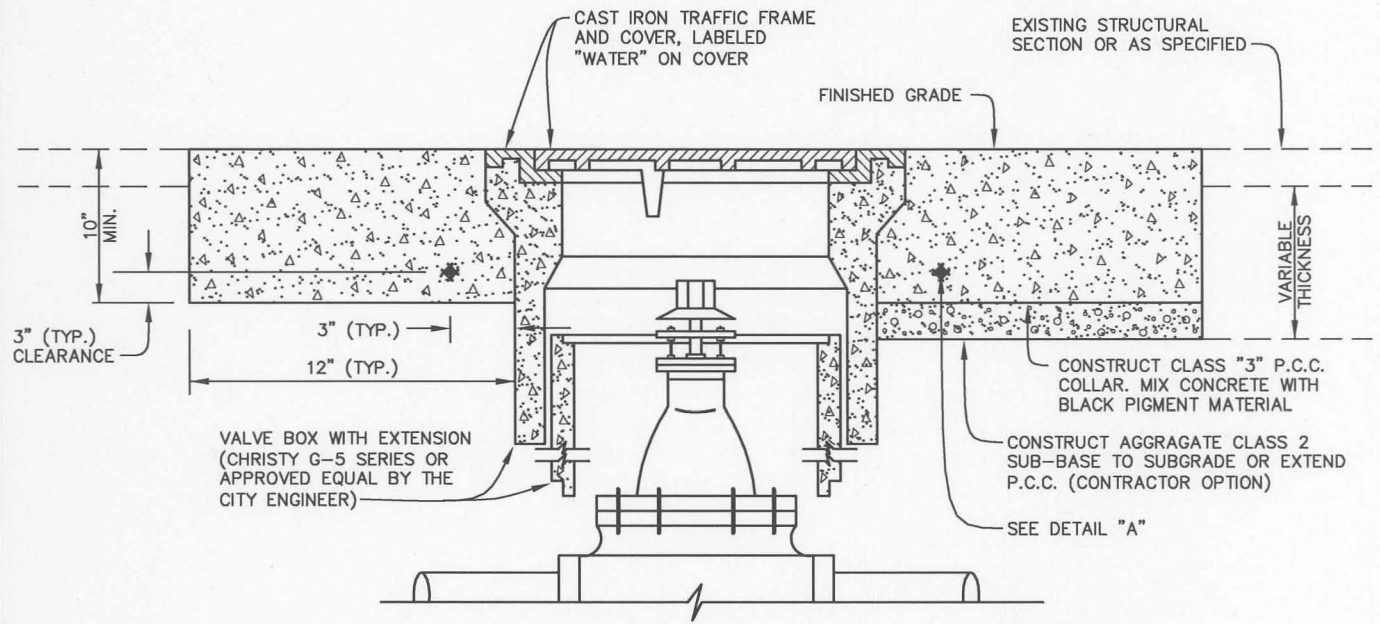

**CONCRETE VALVE BOX DETAIL**

**GENERAL NOTES**

1. DRAWING NOT TO SCALE.
2. P.C.C. SHALL BE CLASS "3" AND CONSTRUCTED PER SECTION 51 OF THE CITY STANDARD SPECIFICATIONS. MIX CONCRETE WITH BLACK PIGMENT MATERIAL.
3. ALL CASTINGS SHALL BE GRAY CAST IRON CONFORMING TO ASTM A-48, CLASS 30 FREE FROM CRACKS, HOLES, SWELLS, AND OTHER DEFECTS. ALL BEARING SURFACES SHALL BE MACHINED.

**DEVELOPMENT & ENGINEERING SERVICES DEPARTMENT**  
 ENGINEERING SERVICES DIVISION CITY OF SALINAS

TITLE: **VALVE BOX INSTALLATION**

**STANDARD PLAN**

DESIGNED BY:  
STAFF

CADD BY:  
STAFF

PROJECT MANAGER:  
FRANK A. AGUAYO, P.E.

DATE 10/21/2008

*Robert C. Russell*

ROBERT C. RUSSELL, CITY ENGINEER  
R.C.E. 42871, EXPIRES 3-31-2010



**35**

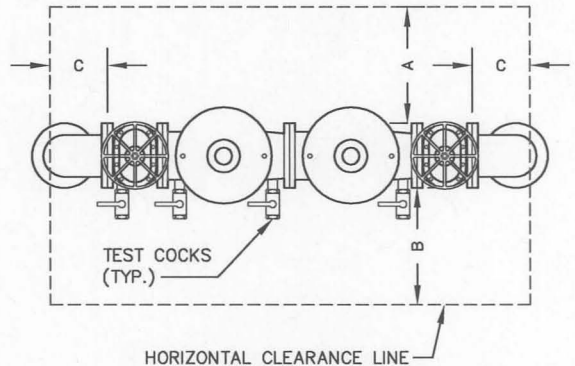
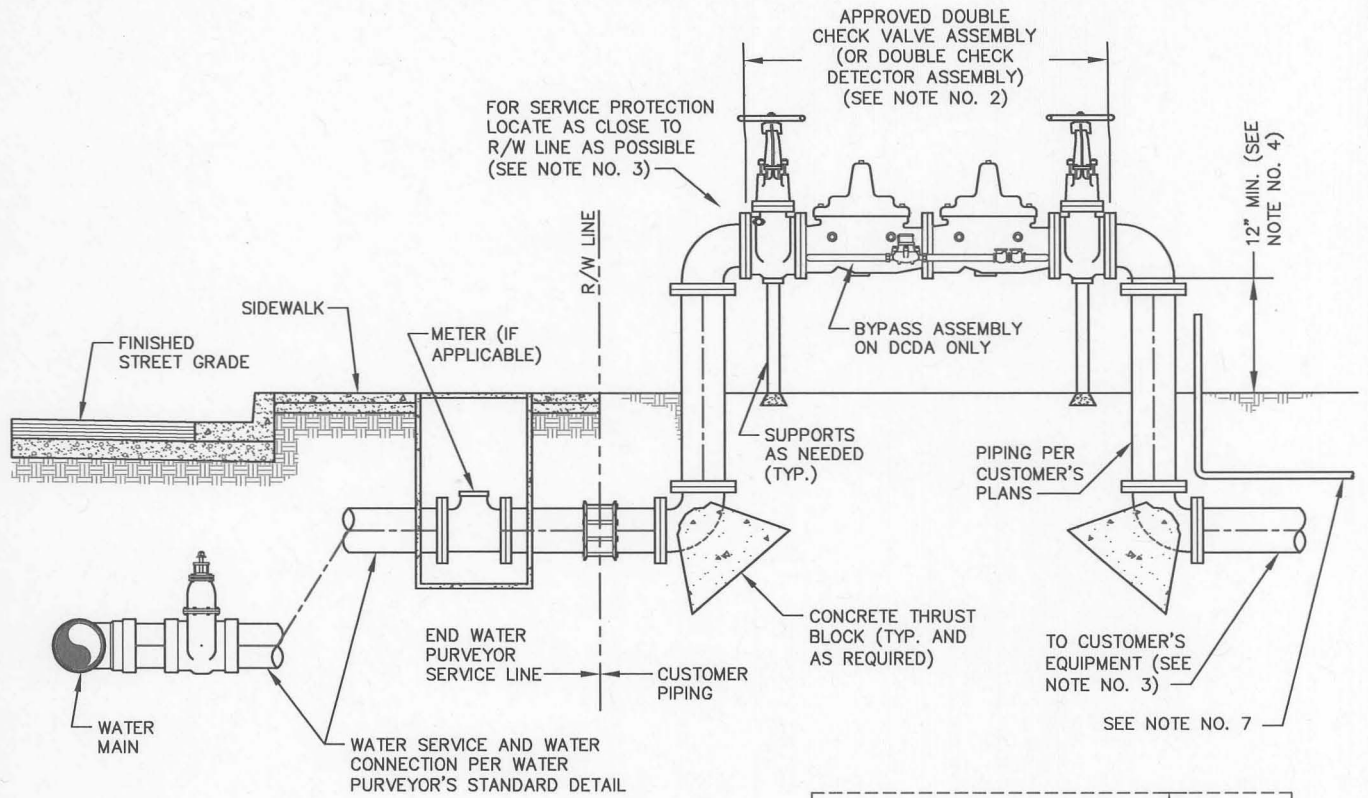

CLEARANCE DIMENSIONS			
SIZE	A	B	C
1"-3"	12"	18"	12"
4" & UP	24"	24"	12"

**GENERAL NOTES**

1. DRAWING NOT TO SCALE.
2. SEE CALIFORNIA STATE DEPARTMENT OF HEALTH SERVICES LIST OF APPROVED BACKFLOW PREVENTION ASSEMBLIES.
3. THE LOCATION AND INSTALLATION OF THE APPROVED ASSEMBLY SHALL BE SUBJECT TO THE APPROVAL OF THE WATER PURVEYOR CROSS-CONNECTION CONTROL SUPERVISOR.
4. INSTALL UNIT A MINIMUM OF 12" AND A MAXIMUM OF 36" ABOVE FINISHED GRADE AND NOT SUBJECT TO FLOODING.
5. PRESSURE/TEMPERATURE RELIEF VALVE INSTALLATION AND/OR THERMAL EXPANSION CONTROL EQUIPMENT SHOULD BE PROVIDED (AS NEEDED).
6. APPROVED PROTECTIVE ENCLOSURES MAY BE INSTALLED IN ACCORDANCE WITH WATER PURVEYOR AND/OR CITY REQUIREMENTS.
7. 1" PVC CONDUIT FOR FIRE ALARM SUPERVISION OF ABOVE GROUND WATER CONTROL VALVES.

**DEVELOPMENT & ENGINEERING SERVICES DEPARTMENT**  
ENGINEERING SERVICES DIVISION CITY OF SALINAS

---

**TITLE: DOUBLE CHECK VALVE - BACK FLOW PREVENTER ASSEMBLY AND INSTALLATION** **STANDARD PLAN**

DESIGNED BY: STAFF	DATE: 10/21/2008		REVIEWED BY: <i>M. Latham</i>
CADD BY: STAFF	<i>Robert C. Russell</i>		<b>FIRE CHIEF SALINAS FIRE DEPT.</b>
PROJECT MANAGER: FRANK A. AGUAYO, P.E.	ROBERT C. RUSSELL, CITY ENGINEER R.C.E. 42871, EXPIRES 3-31-2010		<b>36</b>

**LANELINE** (CALTRANS STD. PLAN A20A, DETAIL 9 & 12)

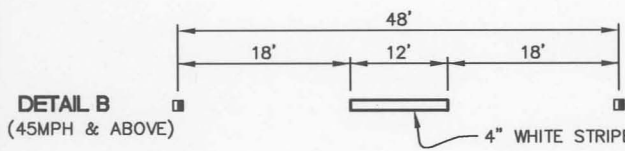
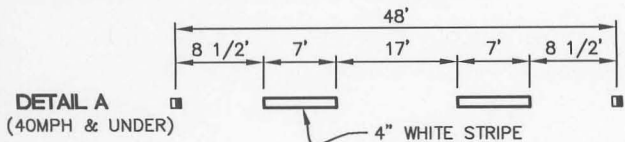

**CENTERLINE** (CALTRANS STD. PLAN A20A, DETAIL 2 & 6)

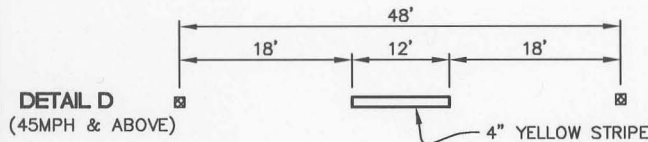
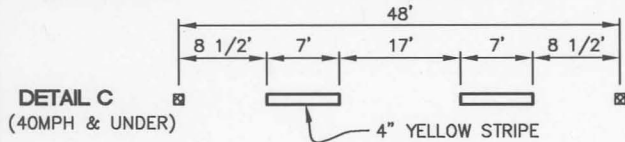

**CHANNELIZING LANE**  
(CALTRANS STD. PLAN A20D, DETAIL 38)

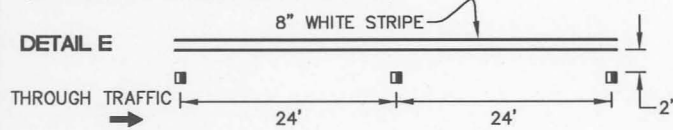

**NO PASSING ZONES**  
(TWO DIRECTION) (CALTRANS STD. PLAN A20A, DETAIL 22)

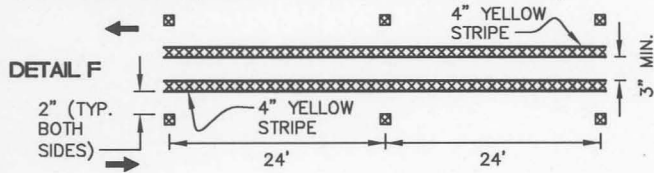

**LANE DROP**

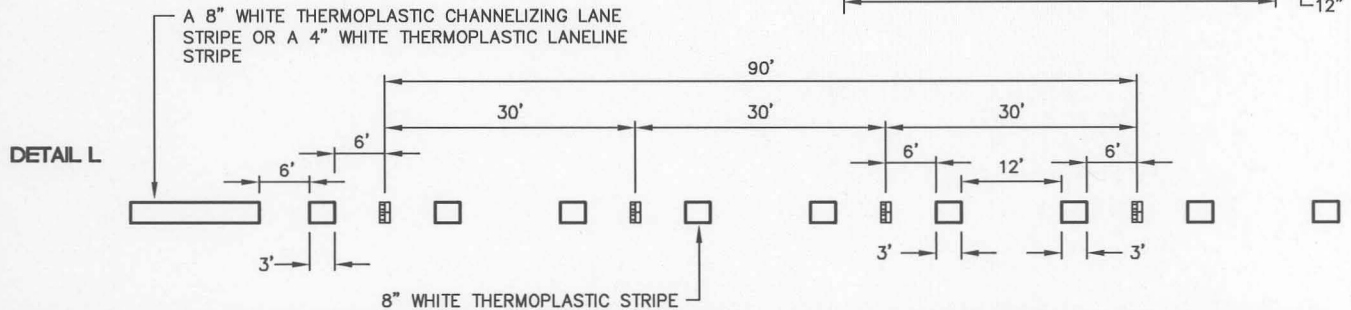

**PAINTED MEDIAN ISLAND**  
(CALTRANS STD. PLAN A20B, DETAIL 29)

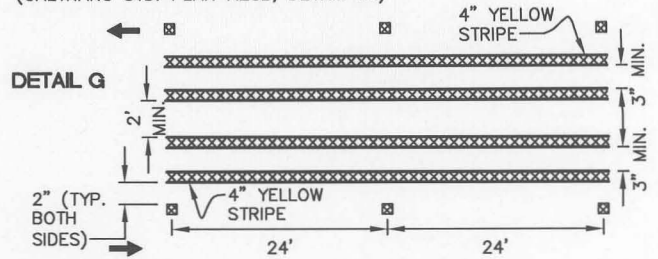

**STOP APPROACH**

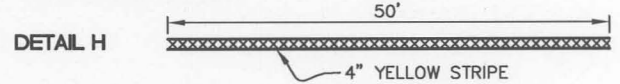

**TWO WAY LEFT TURN LANE**  
(CALTRANS STD. PLAN A20B, DETAIL 32)

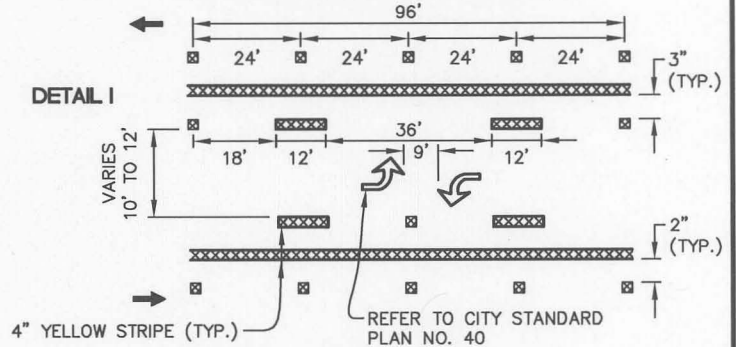

**RIGHT EDGELINE**  
(CALTRANS STD. PLAN A20B, DETAIL 27B)

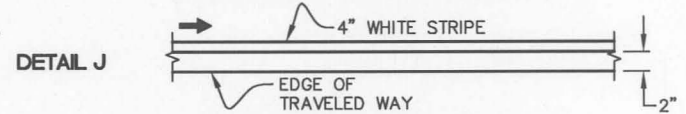

**RAISED MEDIAN ISLAND**

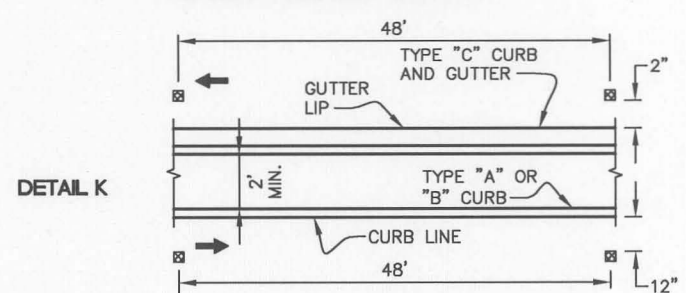

**DEVELOPMENT & ENGINEERING SERVICES DEPARTMENT**

ENGINEERING SERVICES DIVISION

CITY OF SALINAS

TITLE: **THERMOPLASTIC STRIPING**

**STANDARD PLAN**

DESIGNED BY:  
STAFF

DATE 10/21/2008

CADD BY:  
STAFF

*Robert C. Russell*  
ROBERT C. RUSSELL, CITY ENGINEER  
R.C.E. 42871, EXPIRES 3-31-2010

PROJECT MANAGER:  
FRANK A. AGUAYO, P.E.

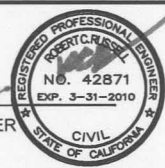

**37A**

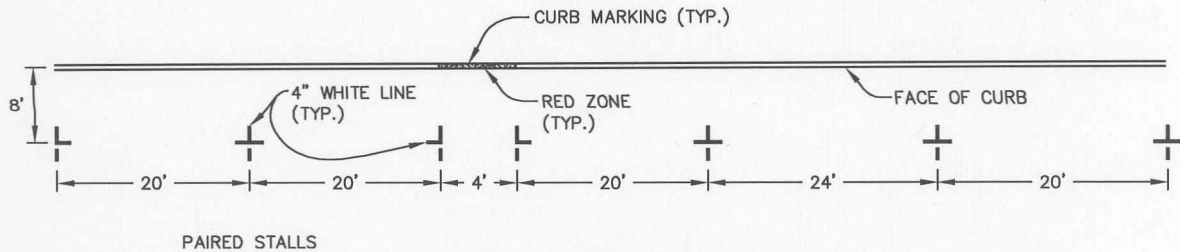

**PARALLEL STALL DETAIL**

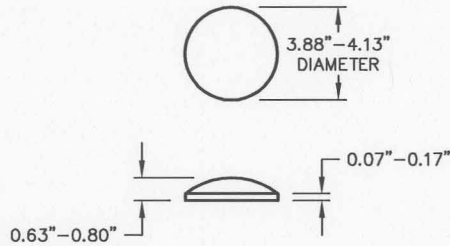

**RAISED PAVEMENT DOME MARKER**

**LEGEND**

- TYPE A WHITE DOME MARKER (NON-REFLECTIVE)
- ⊗ TYPE AY YELLOW DOME MARKER (NON-REFLECTIVE)
- TYPE G: ONE WAY CLEAR REFLECTIVE (HIGH INTENSITY)
- ▣ TYPE D: TWO WAY YELLOW REFLECTIVE (HIGH INTENSITY)
- ▤ TYPE C: RED-CLEAR REFLECTIVE (HIGH INTENSITY)
- TYPE BB: TWO WAY BLUE REFLECTIVE (HIGH INTENSITY) FOR FIRE HYDRANT
- ➔ DIRECTION OF TRAVEL

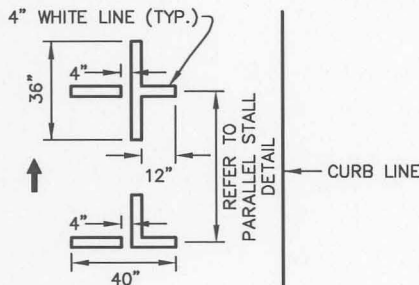

**PARKING TEE DETAIL**

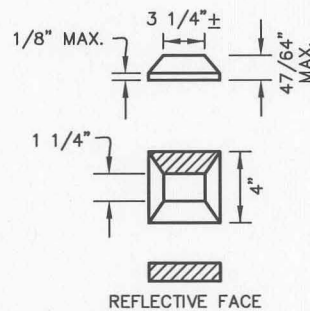

**RAISED PAVEMENT MARKER DETAIL**

**GENERAL NOTES**

1. DRAWING NOT TO SCALE.
2. RAISED PAVEMENT MARKERS SHALL BE STIMSONITE (OR APPROVED EQUAL BY THE CITY ENGINEER).
3. LOCATION AND PLACEMENT OF CONTROL POINTS AND PRELIMINARY MARKINGS ARE SUBJECT TO APPROVAL BY THE CITY ENGINEER.
4. THERMOPLASTIC SHALL BE INSTALLED AS SPECIFIED IN THE CITY STANDARD SPECIFICATIONS.
5. LOCATION AND QUANTITY OF TYPE BB RPM SHALL BE AS REQUIRED PER CITY STANDARD PLAN NO. 38.
6. TWO WAY LEFT TURN ARROWS SHALL BE INSTALLED 50' FROM THE BEGINNING AND END OF LEFT TURN LANE. THE SPACING BETWEEN THE BEGINNING AND END FOR ADDITIONAL LEFT TURN ARROWS SHALL BE DETERMINED BY THE CITY ENGINEER.
7. RED ZONE SHALL BE RED REFLECTIVE PAINT WITH TYPE II REFLECTIVE GLASS SPHERE PAINT PER CITY OF SALINAS STANDARD SPECIFICATIONS.

**DEVELOPMENT & ENGINEERING SERVICES DEPARTMENT**

ENGINEERING SERVICES DIVISION CITY OF SALINAS

<b>TITLE: THERMOPLASTIC STRIPING</b>		<b>STANDARD PLAN</b>
DESIGNED BY: STAFF	DATE: 10/21/2008	<b>37B</b>
CADD BY: STAFF	<i>Robert Russell</i>	
PROJECT MANAGER: FRANK A. AGUAYO, P.E.	ROBERT C. RUSSELL, CITY ENGINEER R.C.E. 42871, EXPIRES 3-31-2010	





**TWO LANE STREET**

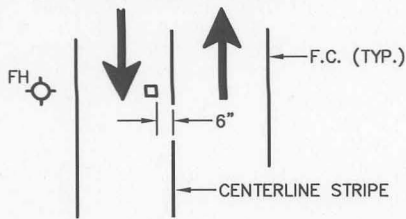

**MULTI-LANE STREET**

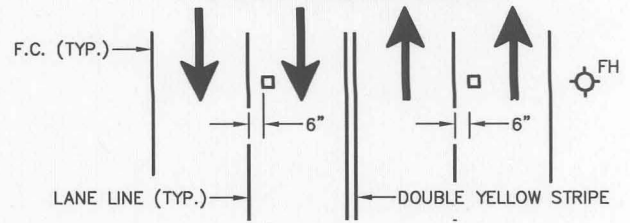

**TWO LANE STREET AT INTERSECTION**

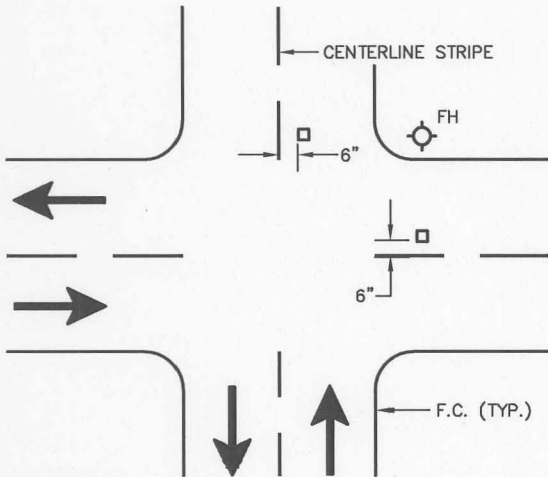

**FOUR LANE STREET WITH TURN LANE AT INTERSECTION**

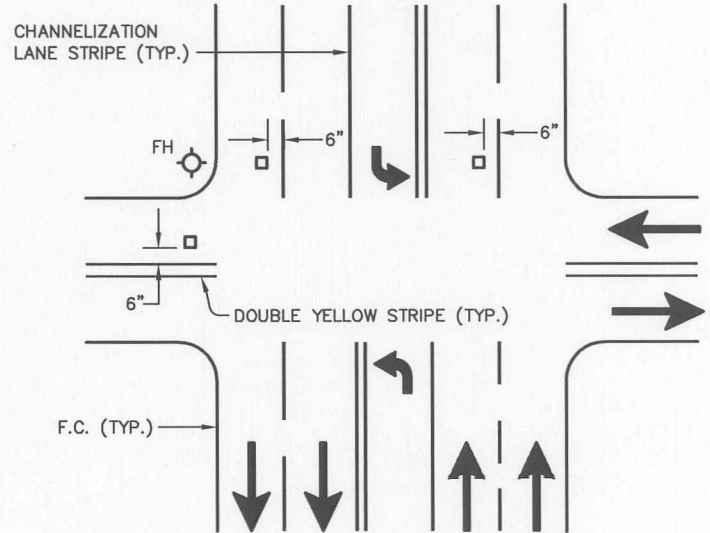

**MULTI-LANE STREET WITH TWO WAY LEFT TURN LANE**

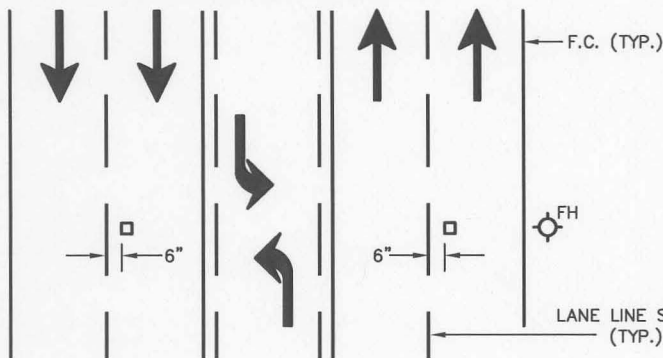

**MULTI-LANE STREET WITH MEDIAN ISLAND**

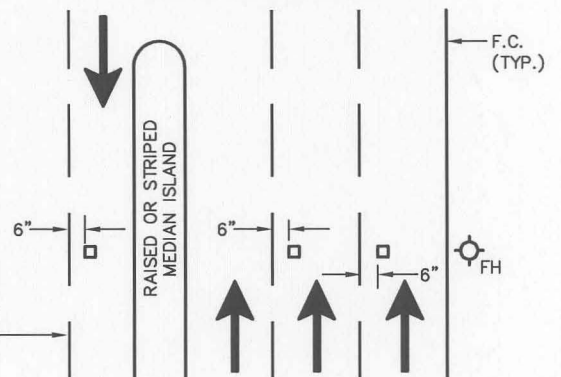

**GENERAL NOTES**

1. DRAWING NOT TO SCALE
2. REFER TO CITY STANDARD PLAN NO. 37B FOR DIMENSION OF RAISED PAVEMENT MARKER.

**LEGEND**

- FH FIRE HYDRANT
- TYPE BB: TWO WAY BLUE REFLECTIVE (HIGH INTENSITY) RAISED PAVEMENT MARKER
- DIRECTION OF TRAVEL

**DEVELOPMENT & ENGINEERING SERVICES DEPARTMENT**

ENGINEERING SERVICES DIVISION

CITY OF SALINAS

**TITLE: FIRE HYDRANT PAVEMENT MARKER LOCATION**

**STANDARD PLAN**

DESIGNED BY:  
STAFF

DATE 10/21/2008

CADD BY:  
STAFF

*Robert C. Russell*

PROJECT MANAGER:  
FRANK A. AGUAYO, P.E.

ROBERT C. RUSSELL, CITY ENGINEER  
R.C.E. 42871, EXPIRES 3-31-2010

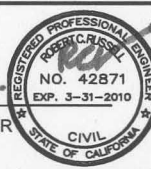

REVIEWED BY:  
*M. Fathom*

FIRE CHIEF  
SALINAS FIRE DEPT.

**38**

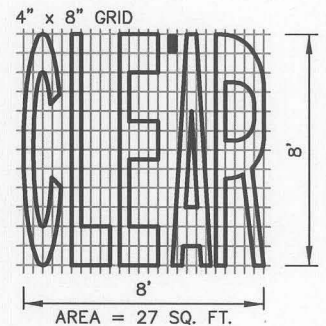
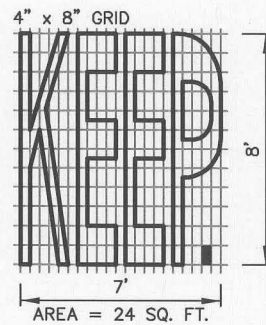
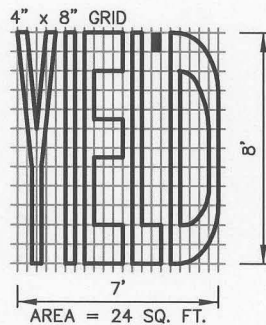
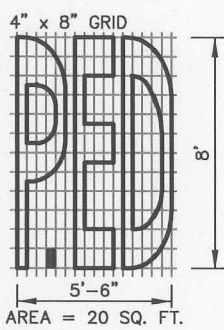
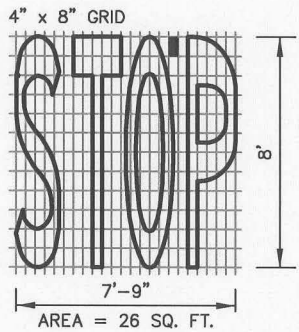
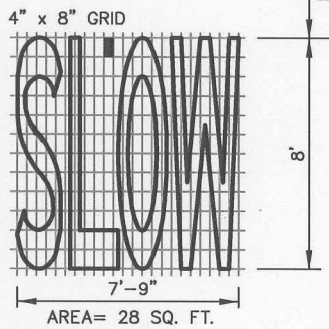
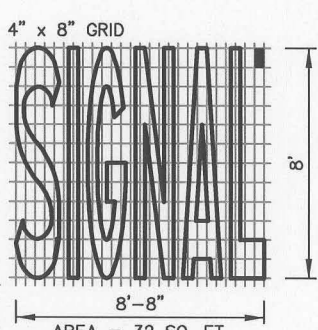
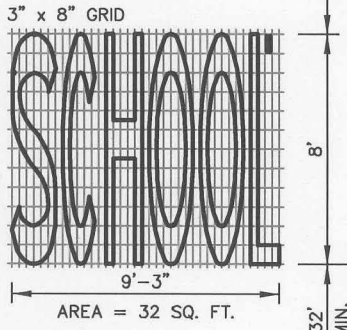
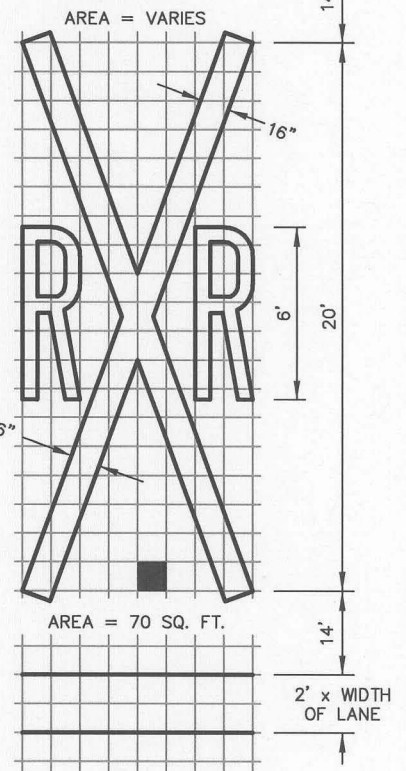
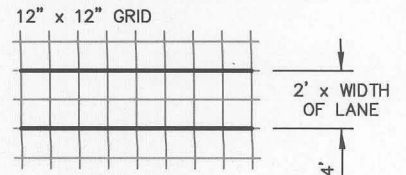
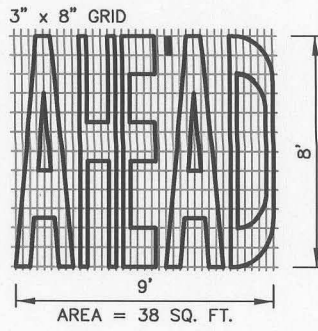
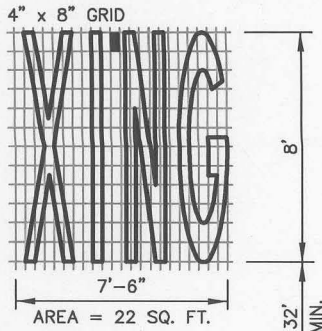

**GENERAL NOTES**

1. DRAWING NOT TO SCALE.
2. LOCATION AND PLACEMENT OF CONTROL POINTS AND PRELIMINARY MARKINGS ARE SUBJECT TO APPROVAL BY THE CITY ENGINEER.
3. SLOW-SCHOOL-XING LEGEND AND SCHOOL CROSSWALKS SHALL BE YELLOW THERMOPLASTIC UNLESS DESIGNATED OTHERWISE BY THE CITY ENGINEER, ALL OTHER PAVEMENT MARKINGS SHALL BE WHITE THERMOPLASTIC.
4. IF A MESSAGE CONSISTS OF MORE THAN ONE WORD, IT SHOULD READ "UP", THE FIRST WORD SHOULD BE NEAREST THE DRIVER.
5. THE SPACE BETWEEN WORDS SHALL EQUAL THE SPEED LIMIT OF THE ROADWAY UNLESS DESIGNATED OTHERWISE BY THE CITY ENGINEER. THE SPACE MAY BE REDUCED APPROPRIATELY WHERE THERE IS LIMITED SPACE BECAUSE OF LOCAL CONDITIONS AS APPROVED BY THE CITY ENGINEER.
6. PORTIONS OF A LETTER, NUMBER, OR SYMBOL MAY BE SEPARATED BY CONNECTING SEGMENTS NOT TO EXCEED 2" IN WIDTH.
7. THERMOPLASTIC SHALL BE INSTALLED AS SPECIFIED IN THE CITY STANDARD SPECIFICATIONS.
8. MINOR VARIATIONS IN DIMENSIONS ARE SUBJECT TO APPROVAL BY THE CITY ENGINEER.

**DEVELOPMENT & ENGINEERING SERVICES DEPARTMENT**

ENGINEERING SERVICES DIVISION

CITY OF SALINAS

TITLE: **PAVEMENT MARKING LEGENDS AND WORDS**

**STANDARD PLAN**

DESIGNED BY:

STAFF

DATE 10/21/2008

CADD BY:

STAFF

*Robert C. Russell*

PROJECT MANAGER:

FRANK A. AGUAYO, P.E.

ROBERT C. RUSSELL, CITY ENGINEER  
 R.C.E. 42871, EXPIRES 3-31-2010



**39**

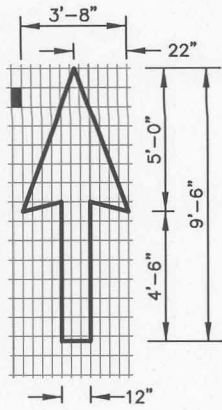

4" x 8" GRID  
AREA = 14 SQ. FT.

**STRAIGHT ARROW**

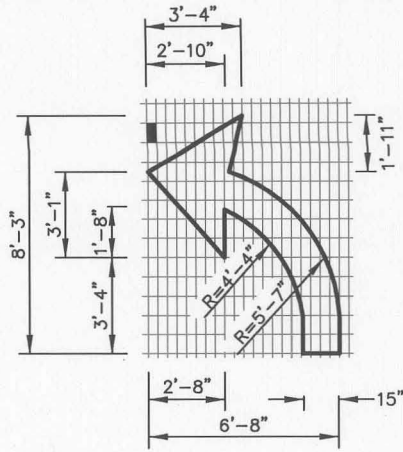

4" x 8" GRID  
AREA = 14 SQ. FT.

**LEFT/RIGHT TURN ARROW**

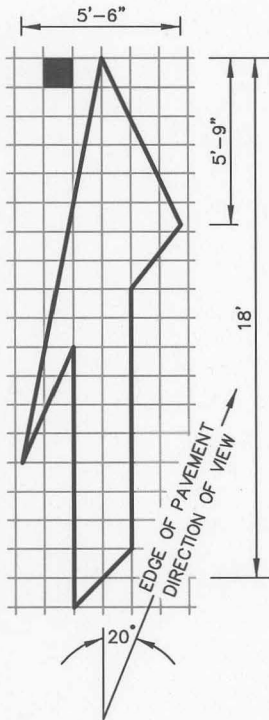

12" x 12" GRID  
AREA = 42 SQ. FT.

**RIGHT LANE MERGE ARROW**

(FOR LEFT MERGE ARROW USE MIRROR IMAGE)

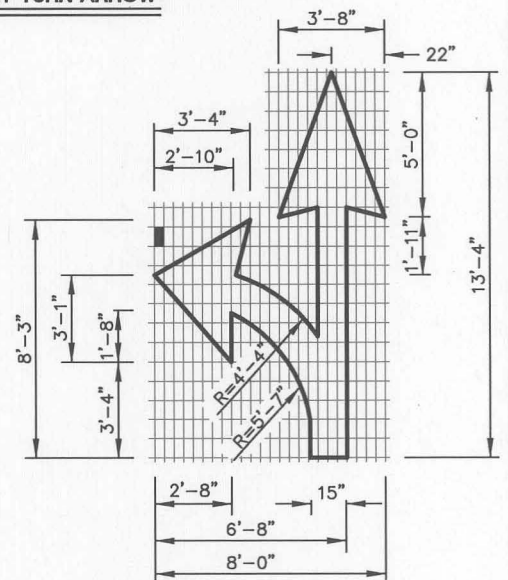

4" x 8" GRID  
AREA = 28 SQ. FT.

**STRAIGHT AND LEFT/RIGHT TURN ARROW COMBO**

**GENERAL NOTES**

1. DRAWING NOT TO SCALE.
2. LOCATION AND PLACEMENT OF CONTROL POINTS AND PRELIMINARY MARKINGS ARE SUBJECT TO APPROVAL BY THE CITY ENGINEER.
3. MINOR VARIATIONS IN DIMENSIONS ARE SUBJECT TO APPROVAL BY THE CITY ENGINEER.
4. THERMOPLASTIC SHALL BE INSTALLED AS SPECIFIED IN THE CITY'S STANDARD SPECIFICATIONS.

**DEVELOPMENT & ENGINEERING SERVICES DEPARTMENT**

ENGINEERING SERVICES DIVISION

CITY OF SALINAS

TITLE: **PAVEMENT MARKINGS ARROWS**

**STANDARD PLAN**

DESIGNED BY:  
STAFF

DATE 10/21/2008

CADD BY:  
STAFF

*Robert C. Russell*

PROJECT MANAGER:  
FRANK A. AGUAYO, P.E.

ROBERT C. RUSSELL, CITY ENGINEER  
R.C.E. 42871, EXPIRES 3-31-2010



**40**

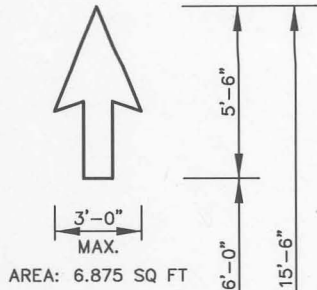

**BIKE SYMBOL WITH ARROW**

DETAIL "A"

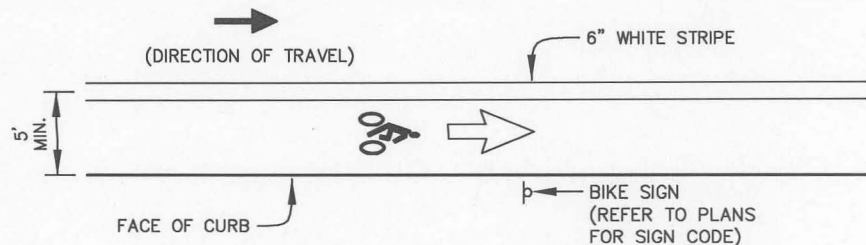

**BIKE LANE LINE**

DETAIL "B"

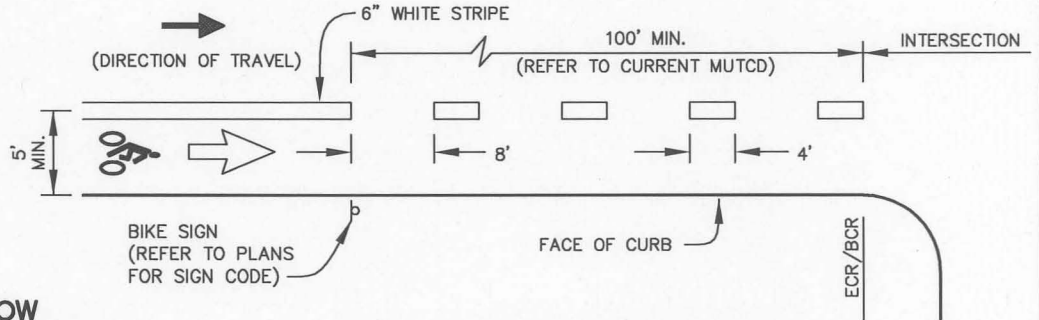

**BIKE LANE LINE AT INTERSECTION**

DETAIL "C"

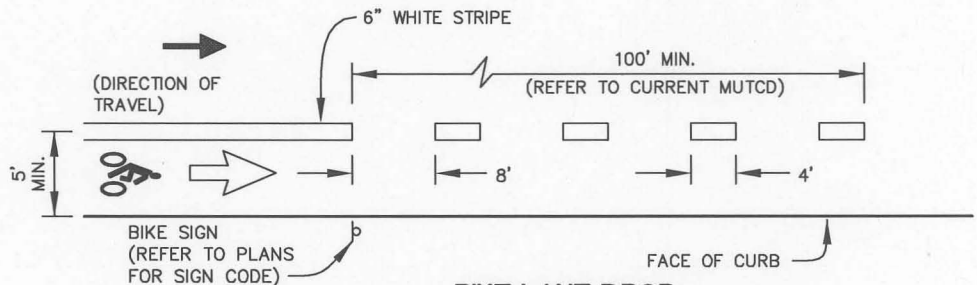

**BIKE LANE DROP**

DETAIL "D"

**GENERAL NOTES**

1. DRAWING NOT TO SCALE
2. LOCATION AND PLACEMENT OF CONTROL POINTS AND PRELIMINARY MARKINGS SHALL BE SUBJECT TO APPROVAL BY THE CITY ENGINEER (SEE SALINAS BIKEWAYS PLAN FOR GUIDING POLICY)
3. ALL WHITE STRIPES, ARROWS, AND SYMBOLS SHALL BE THERMOPLASTIC. 120 MIL FOR MAJOR STREETS AND 90 MIL FOR MINOR/RESIDENTIAL STREETS. THERMOPLASTIC PREFABRICATED BIKE SYMBOL AND ARROW SHALL BE FURNISHED AND INSTALLED BY THE CONTRACTOR PER MANUFACTURER'S SPECIFICATIONS.
4. BIKE SYMBOL WITH ARROW SHOULD READ "UP". THE BIKE SYMBOL SHOULD BE NEAREST THE DRIVER.
5. BIKE SYMBOL LEGEND AND ARROW SHALL BE WHITE THERMOPLASTIC.
6. MINOR VARIATIONS IN DIMENSIONS ARE SUBJECT TO APPROVAL BY THE CITY ENGINEER.

**DEVELOPMENT & ENGINEERING SERVICES DEPARTMENT**

ENGINEERING SERVICES DIVISION

CITY OF SALINAS

TITLE: **BIKE LANE**

**STANDARD PLAN**

DESIGNED BY:  
STAFF

DATE 10/21/2008

CADD BY:  
STAFF

*Robert C. Russell*



PROJECT MANAGER:  
FRANK A. AGUAYO, P.E.

ROBERT C. RUSSELL, CITY ENGINEER  
R.C.E. 42871, EXPIRES 3-31-2010

**41**





STATE STANDARD R99C (CA)  
SIGN 12" x 26" WHITE ON  
BLUE 3" SERIES "B" LETTERS



STATE STANDARD R7-8b (CA)  
SIGN 12" x 8" WHITE ON  
BLUE 1 1/2" SERIES "B"  
LETTERS

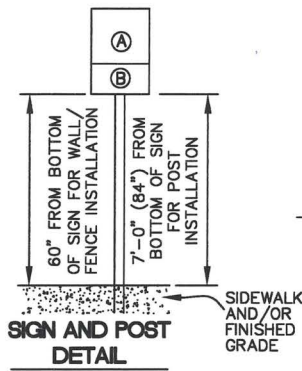

**C DISABLED PARKING ENTRY SIGN**

UNAUTHORIZED VEHICLES  
PARKED IN DESIGNATED  
ACCESSIBLE SPACES NOT  
DISPLAYING DISTINGUISHING  
PLACARDS OR LICENSE PLATES  
ISSUED FOR PERSONS WITH  
DISABILITIES MAY BE TOWED  
AWAY AT OWNER'S EXPENSE.  
TOWED VEHICLES MAY BE  
RECLAIMED AT THE  
**SALINAS POLICE DEPT.**  
OR BY TELEPHONING  
**(831) 758-7321**

1. POSTED IN A CONSPICUOUS PLACE AT EACH ENTRANCE TO A PARKING FACILITY
2. STATE STANDARD SIGN R100B (CA) WITH WHITE LETTERS ON BLUE BACKGROUND. MINIMUM SIGN SIZE 22" x 17", MINIMUM 1" LETTER SIZE BOARDER IS 5/8" THICK WHITE

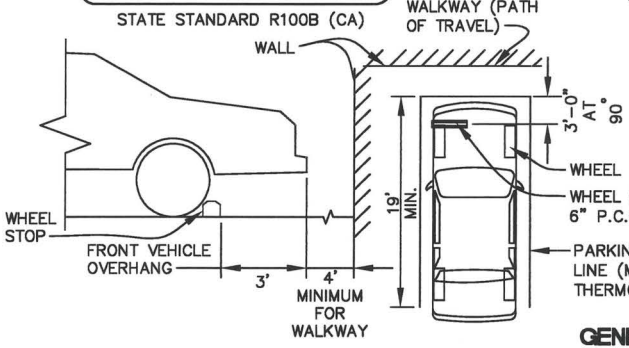

**WHEEL STOP LOCATION**

**OFF STREET PARKING  
(PARKING LOT OR GARAGE)**

TOTAL NUMBER OF PARKING SPACES OR STALLS	MINIMUM NUMBER OF DISABLED ACCESSIBLE PARKING SPACES OR STALLS
1-25	1
26-50	2
51-75	3
76-100	4
101-150	5
151-200	6
201-300	7
301-400	8
401-500	9
501-1000	2 PERCENT OF TOTAL
GREATER THAN 1000	20 PLUS 1 FOR EACH 100 OR FRACTION THEREOF OVER 1000

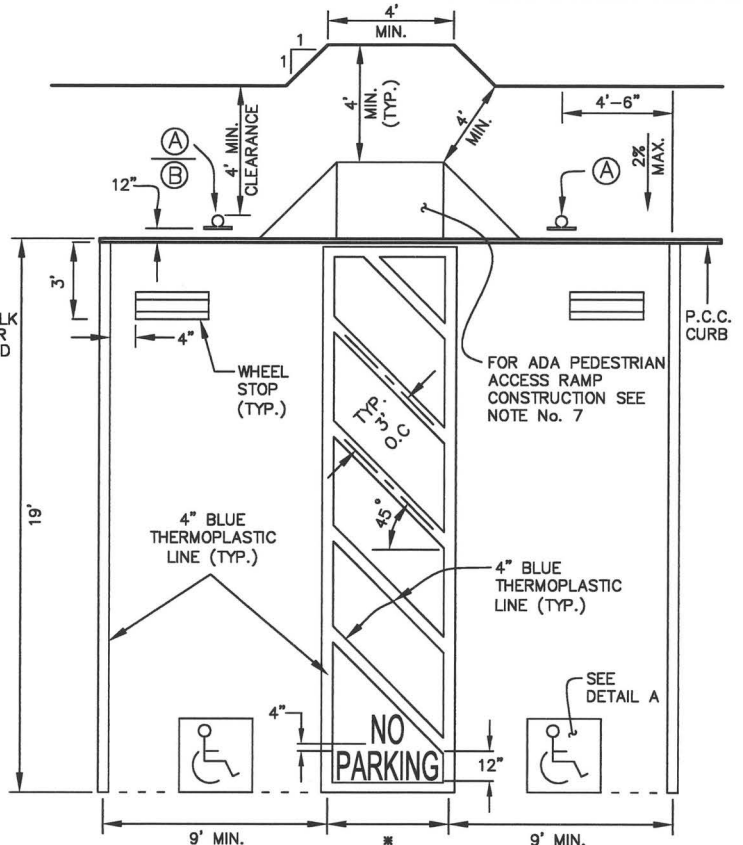

\* 5' MIN. AT TYP. STANDARD ACCESSIBLE PARKING STALL, OR 8' MIN. AT VAN ACCESSIBLE PARKING STALL.

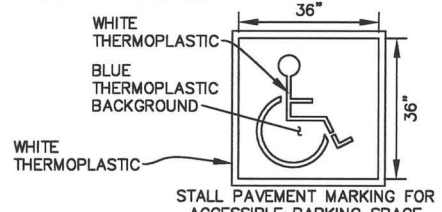

**GENERAL NOTES**

1. DRAWING NOT TO SCALE.
2. PAVEMENT AND STRIPING SHALL BE IN THERMOPLASTIC PER CITY STANDARD SPECIFICATIONS.
3. TRAFFIC SIGN SHALL BE CONSTRUCTED OF 0.08" THICK ALUMINUM ALLOY. SIGN MATERIAL SHALL BE 3M DIAMOND GRADE CUBED REFLECTIVE SHEETING SERIES 4090 (OR APPROVED EQUAL BY THE CITY ENGINEER). THE REFLECTIVE SHEETING SHALL CONFORM WITH THE FEDERAL SPECIFICATIONS L-S300A.
4. PARKING STALLS SHALL HAVE A MINIMUM OF SIDE CLEARANCE OF 1' FROM COLUMNS AND OTHER STRUCTURES. A 4' ACCESS WALKWAY IS REQUIRED UNDER TITLE 24 OF STATE REG.
5. ANGLE PARKING STALLS SHALL BE CONSTRUCTED PER SECTION 37-177 OF THE SALINAS CITY CODE. ALL LAYOUTS SHALL BE APPROVED BY THE CITY ENGINEER.
6. LOCATION AND PLACEMENT OF CONTROL POINTS AND PRELIMINARY MARKINGS ARE SUBJECT TO APPROVAL BY THE CITY ENGINEER. SIGNS SHALL BE IN ACCORDANCE WITH SECTION 56-2 OF THE CITY STANDARD SPECIFICATIONS AND PLANS.
7. FOR ON-STREET PARKING, ADA COMPLIANT PEDESTRIAN ACCESS RAMPS SHALL CONFORM TO THE LATEST CALTRANS STANDARD PLANS.
8. A SINGLE ACCESSIBLE PARKING STALL SHALL HAVE A LOADING/UNLOADING ACCESS AISLE ON THE PASSENGER SIDE OF THE VEHICLE. WHEN TWO ACCESSIBLE PARKING STALLS ARE ADJACENT TO EACH OTHER, THE ACCESS AISLE MAY BE SHARED BETWEEN THE TWO PARKING STALLS.
9. FOR ACCESSIBLE DIAGONAL PARKING REFER TO CALTRANS LATEST REVISED STANDARD PLANS.
10. ONE IN EVERY 6 OR FRACTION OF 6 OFF-STREET ACCESSIBLE PARKING SPACES SHALL BE A VAN ACCESSIBLE SPACE.

**DETAIL A**

**PUBLIC WORKS DEPARTMENT**

ENGINEERING SERVICES DIVISION

CITY OF SALINAS

TITLE: **OFF-STREET AND ON-STREET ACCESSIBLE PARKING**

**STANDARD PLAN**

DESIGNED BY:  
STAFF  
CADD BY:  
STAFF  
PROJECT MANAGER:  
EDA M. HERRERA , P.E.

DATE 2/3/2017  
  
FRANCISCO A. AGUAYO,  
CITY ENGINEER, R.C.E. 59378



**42R**

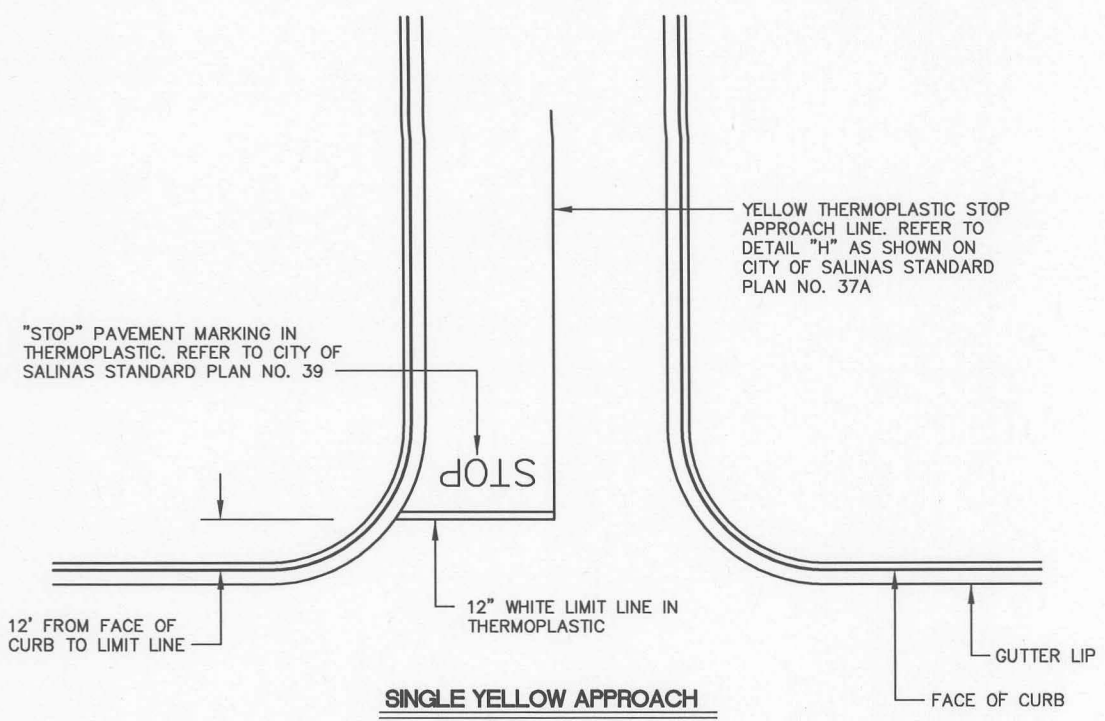

SINGLE YELLOW APPROACH

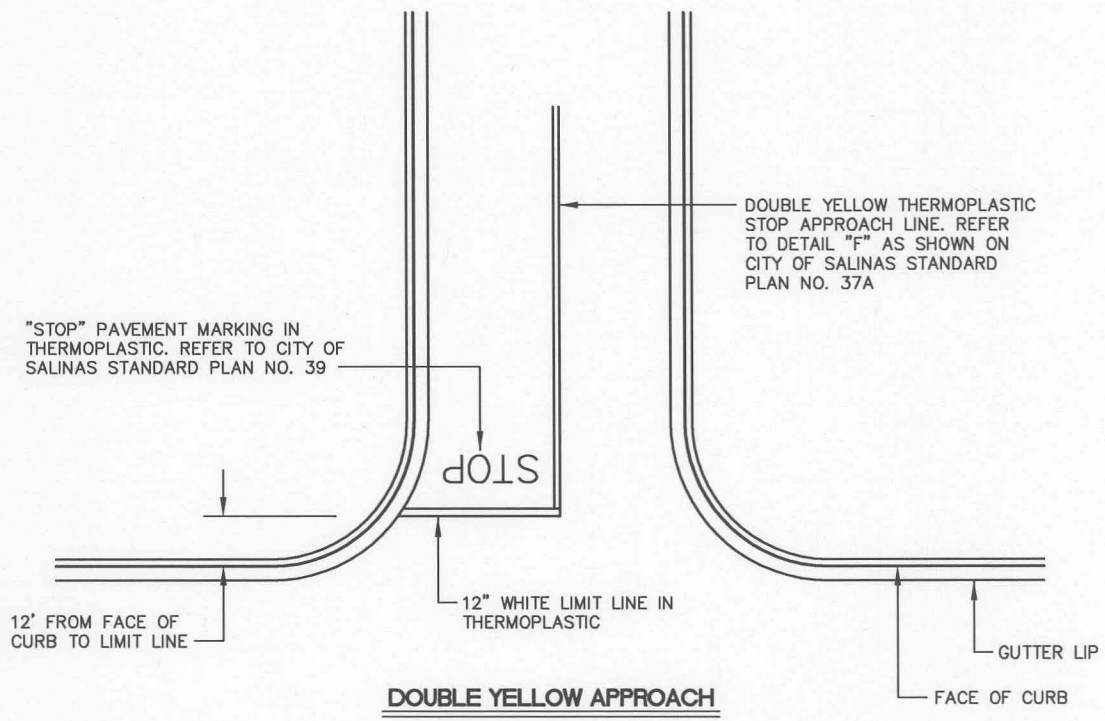

DOUBLE YELLOW APPROACH

GENERAL NOTES

- 1. DRAWING NOT TO SCALE.

DEVELOPMENT & ENGINEERING SERVICES DEPARTMENT  
 ENGINEERING SERVICES DIVISION CITY OF SALINAS

TITLE: **LIMIT LINE INSTALLATION**

STANDARD PLAN

DESIGNED BY:  
STAFF  
 CADD BY:  
STAFF  
 PROJECT MANAGER:  
FRANK A. AGUAYO, P.E.

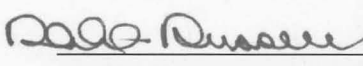
DATE 10/21/2008  
  
 ROBERT C. RUSSELL, CITY ENGINEER  
 R.C.E. 42871, EXPIRES 3-31-2010



**43**

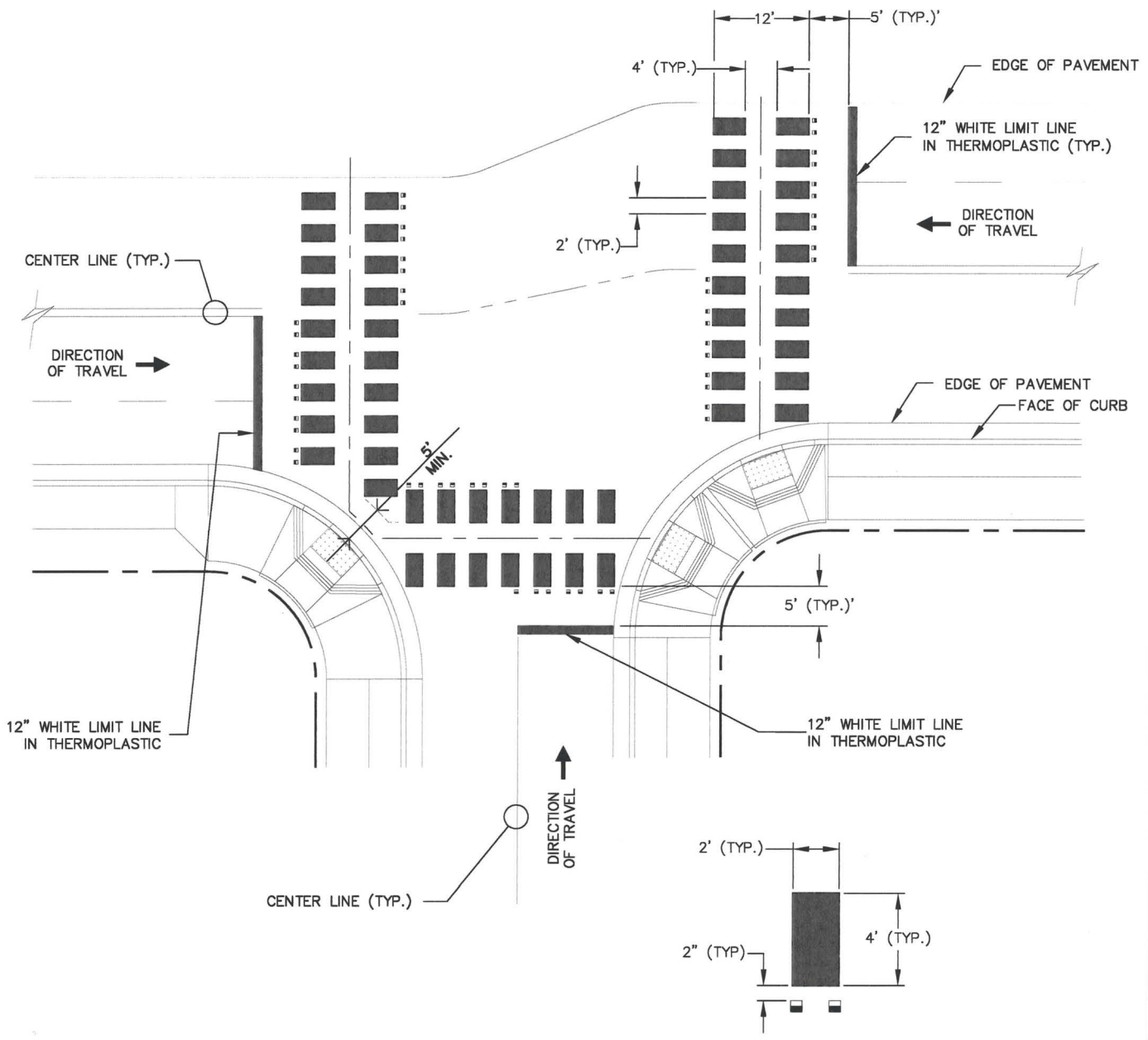

**TYPE G RAISED PAVEMENT MARKER DETAIL**

SCALE: NONE

**GENERAL NOTES**

1. DRAWING NOT TO SCALE.
2. WHITE THERMOPLASTIC SHALL BE USED ON STANDARD CROSSWALKS. YELLOW THERMOPLASTIC SHALL BE USED FOR SAFE ROUTE TO SCHOOL CROSSWALKS (ROUTES DETERMINED BY CITY ENGINEER).
3. ALL CROSSWALKS SHALL BE TRIPLE-4 TYPE.
4. NO RAISED PAVEMENT MARKERS SHALL BE INSTALLED WITHIN BIKE LANES.
5. TYPE G RAISED PAVEMENT MARKER SHALL BE PER CITY OF SALINAS STANDARD PLAN NO. 37B.

**PUBLIC WORKS DEPARTMENT**

ENGINEERING SERVICES DIVISION

CITY OF SALINAS

TITLE: **TRIPLE-4 CROSSWALK**

**STANDARD PLAN**

DESIGNED BY:  
STAFF

CADD BY:  
PHAVANA A.

PROJECT MANAGER:  
EDA M. HERRERA, P.E.

DATE 2/3/2017

FRANCISCO A. AGUAYO,  
CITY ENGINEER, R.C.E. 59378

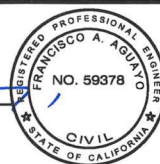

**44R**



ACCEPTABLE DEVICES



PORTABLE DELINEATOR

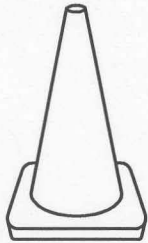

TRAFFIC CONE

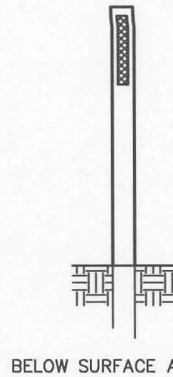

BELOW SURFACE ANCHOR

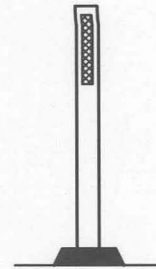

SURFACE MOUNT

PERMANENT TYPE CHANNELIZER

NOT ACCEPTABLE DEVICES

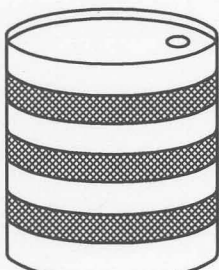

USED OIL DRUM

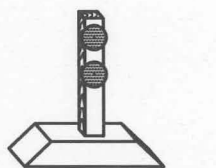
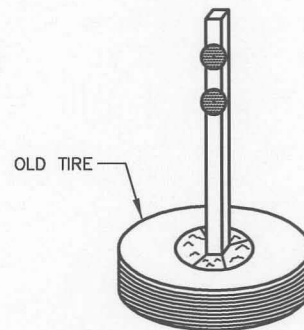
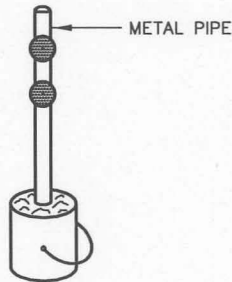

CONCRETE OR METAL BASE

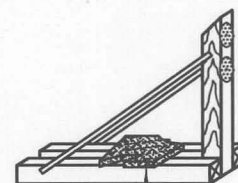
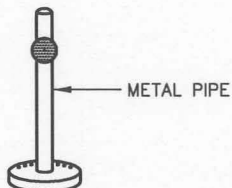

ROCK OR CHUNK OF CONCRETE

GENERAL NOTES

1. REFLECTORIZED MATERIAL FOR THE ACCEPTABLE DEVICES SHALL BE WHITE PER THE MOST CURRENT MANUAL ON UNIFORM TRAFFIC CONTROL DEVICE FOR STREETS AND HIGHWAYS.
2. DRAWING NOT TO SCALE.

**DEVELOPMENT & ENGINEERING SERVICES DEPARTMENT**

ENGINEERING SERVICES DIVISION

CITY OF SALINAS

TITLE: **CHANNELIZATION DEVICES**

**STANDARD PLAN**

DESIGNED BY:  
STAFF

DATE 10/21/2008

CADD BY:  
STAFF

*Robert C. Russell*

PROJECT MANAGER:  
FRANK A. AGUAYO, P.E.

ROBERT C. RUSSELL, CITY ENGINEER  
R.C.E. 42871, EXPIRES 3-31-2010

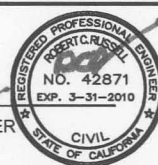

**45**

# WORK AREA TRAFFIC CONTROLS

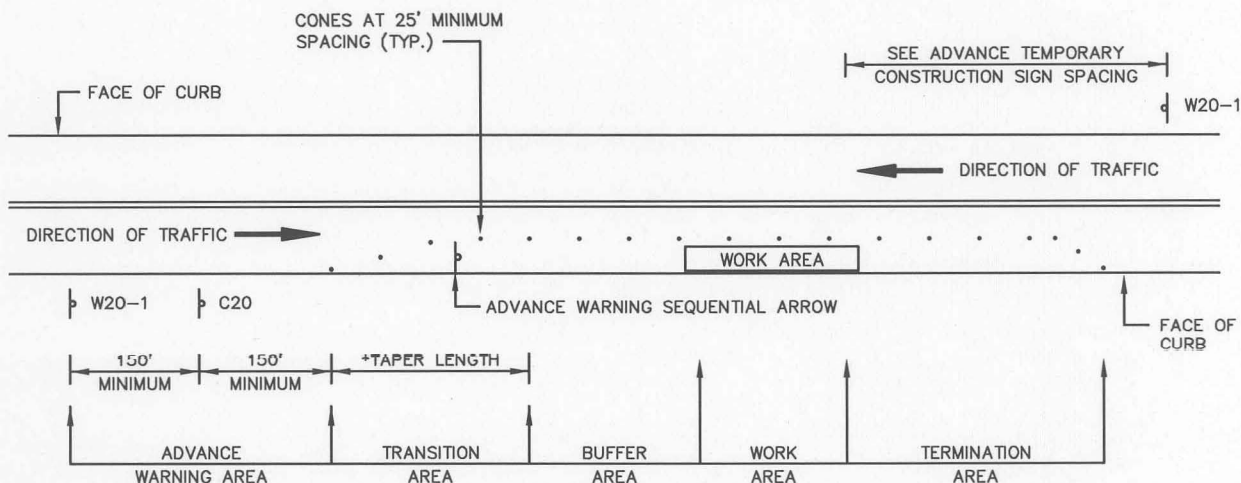

TEMPORARY  
CONSTRUCTION  
SIGN(S)

ADVANCE TEMPORARY  
CONSTRUCTION SIGN SPACING

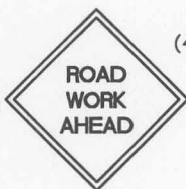

W20-1  
(48" x 48")



FRONT  
C17 (CA)  
(24" x 24")

SPEED LIMIT  
25 TO 35 MPH  
40 MPH AND HIGHER

(ADVANCE OF TAPER AND  
BETWEEN SIGNS)

100'  
350'



W4-7  
(36" x 36")



BACK  
C17 (CA)  
(24" x 24")

SPEED LIMIT  
40 MPH OR LESS  
45 MPH OR MORE

TRAFFIC CONE TAPER

TAPER LENGTH (L) FEET

$L = ws^2 \div 60$   
 $L = ws$



C-20  
(36" x 36")

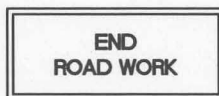

G20-2  
(48" x 24")

WHERE: L = TAPER LENGTH IN FEET  
w = WIDTH OF OFFSET IN FEET  
s = POSTED SPEED LIMIT, OR OFF-PEAK 85TH PERCENTILE SPEED PRIOR TO WORK STARTING, OR THE ANTICIPATED OPERATION SPEED IN MPH

**GENERAL NOTES**

- DRAWING NOT TO SCALE.

**DEVELOPMENT & ENGINEERING SERVICES DEPARTMENT**

ENGINEERING SERVICES DIVISION

CITY OF SALINAS

TITLE: **TYPICAL LANE CLOSURE**

**STANDARD PLAN**

DESIGNED BY:  
STAFF

DATE 10/21/2008

CADD BY:  
STAFF

*Robert C. Russell*

PROJECT MANAGER:  
FRANK A. AGUAYO, P.E.

ROBERT C. RUSSELL, CITY ENGINEER  
R.C.E. 42871, EXPIRES 3-31-2010



46

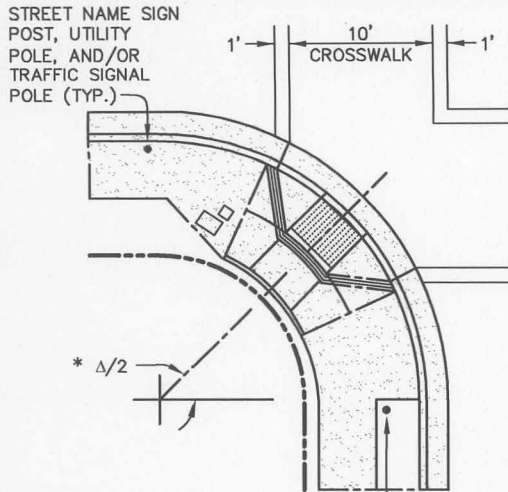

**GENERAL NOTES**

1. DRAWING NOT TO SCALE.
2. STREET NAME SIGNS SHALL BE CONSTRUCTED OF 0.08" THICK ALUMINUM ALLOY.
3. SIGN FINISH SHALL BE 3M DIAMOND GRADE CUBED REFLECTIVE SHEETING SERIES 4090 (OR APPROVED EQUAL BY THE CITY ENGINEER) WITH INTERSTATE GREEN BACKGROUND AND WITH WHITE REFLECTORIZED LETTERS, NUMBERS, AND ARROWS. THE REFLECTIVE SHEETING SHALL CONFORM WITH THE FEDERAL SPECIFICATIONS L-S300A.
4. DIMENSION "X" SHALL HAVE 1' MINIMUM AND 2' MAXIMUM CLEARANCE BETWEEN CURB LINE AND THE FURTHEST PROTRUSION OF THE SIGNS TOWARD THE STREET.
5. SIGN SHALL BE 9" HIGH x 0.08" THICK AND THE LENGTH VARIES.
6. STREET NAME LETTERS SHALL BE CLAREDON BOLD FONT, 5" UPPER CASE, 3 3/4" LOWER CASE, ABBREVIATIONS SHALL BE 2 1/2" UPPER CASE, 1 7/8" LOWER CASE.
7. THE ARROW SHALL POINT IN THE DIRECTION OF INCREASING NUMBERS.
8. MINOR VARIATIONS IN DIMENSIONS ARE SUBJECT TO APPROVAL BY THE CITY ENGINEER.
9. ABBREVIATIONS SHALL BE CENTERED OVER ARROW AND INCREASING NUMBER.
10. STREET NAME SIGN SHALL BE DOUBLE SIDED WITH THE ARROW POINTING IN THE DIRECTION OF INCREASING NUMBER.

"X" SEE NOTE NO. 4

STREET NAME SIGN POST, UTILITY POLE, AND/OR TRAFFIC SIGNAL POLE (TYP.)

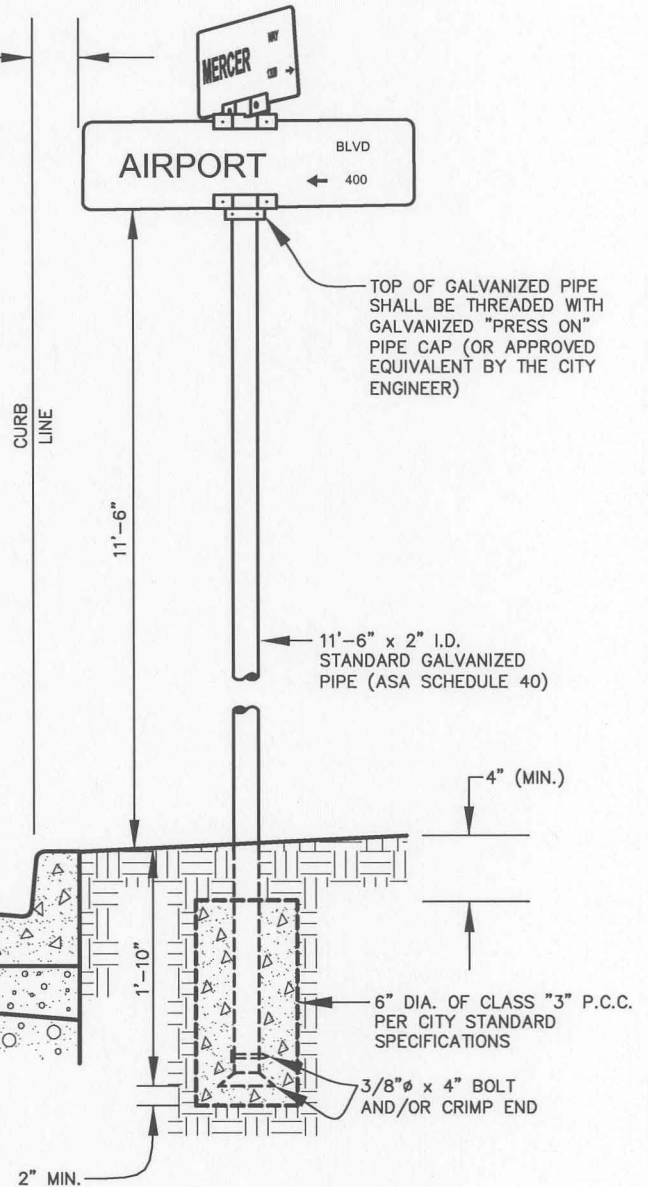

**SIGN INSTALLATION DETAIL**

<b>DEVELOPMENT &amp; ENGINEERING SERVICES DEPARTMENT</b>		CITY OF SALINAS
ENGINEERING SERVICES DIVISION		
TITLE:	<b>STREET NAME SIGN</b>	<b>STANDARD PLAN</b>
DESIGNED BY: STAFF	DATE <u>10/21/2008</u>	<b>47</b>
CADD BY: STAFF	<i>Robert C. Russell</i>	
PROJECT MANAGER: FRANK A. AGUAYO, P.E.	ROBERT C. RUSSELL, CITY ENGINEER R.C.E. 42871, EXPIRES 3-31-2010	

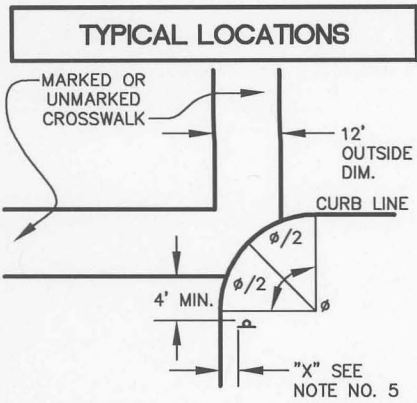

**TYPICAL LOCATIONS**

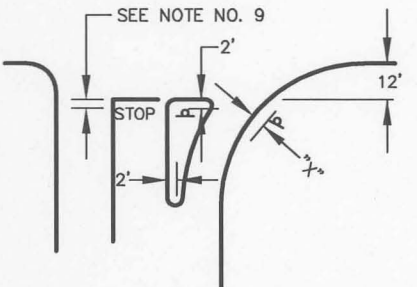

**URBAN INTERSECTION**

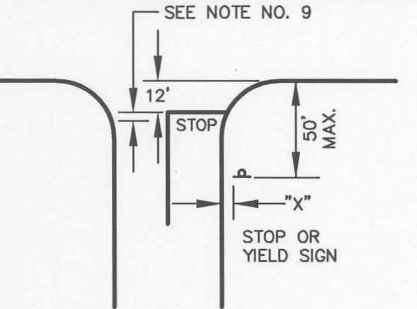

**CHANNELIZED INTERSECTION**

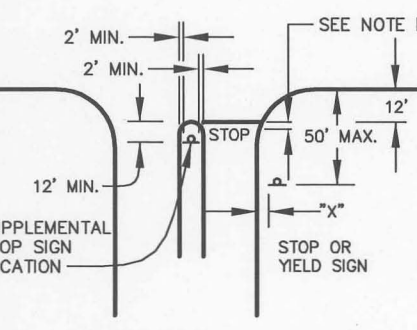

**WIDE THROAT INTERSECTION**

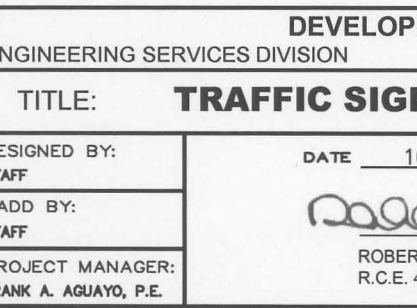

**DIVISIONAL ISLAND**

**GENERAL NOTES**

1. DRAWING NOT TO SCALE.
2. STOP SIGN SHALL BE MINIMUM 30", 36" FOR ALL-WAY WITH R1-4 (ALL WAY). THE SIGN SHALL HAVE 3M DIAMOND GRADE CUBED REFLECTIVE SHEETING SERIES 4090 (OR APPROVED EQUAL BY THE CITY ENGINEER). THE REFLECTIVE SHEETING SHALL CONFORM WITH FEDERAL SPECIFICATIONS L-S300A. THE BACKGROUND OF THE SIGN SHALL BE RED WITH A WHITE BORDER AND LEGEND AND ALL REFLECTIVE.
3. YIELD SIGN SHALL BE 36". THE SIGN SHALL HAVE 3M DIAMOND GRADE CUBED REFLECTIVE SHEETING SERIES 4090 (OR APPROVED EQUAL BY THE CITY ENGINEER). THE REFLECTIVE SHEETING SHALL CONFORM WITH FEDERAL SPECIFICATIONS L-S300-A. THE BACKGROUND OF THE SIGN SHALL BE RED, RED TEXT, WITHIN A WHITE TRIANGLE.
4. SIGNS SHALL ALWAYS BE ERECTED AT THE POINT WHERE THE VEHICLE IS TO STOP OR AS NEAR THERETO AS POSSIBLE. IN NO CASE SHALL EITHER SIGN BE PLACED IN EXCESS OF 50' FROM THE INTERSECTION OF THE ROAD.
5. DIMENSION "X" SHALL HAVE 1' MINIMUM AND 2' MAXIMUM CLEARANCE FROM MAXIMUM SIGN PROTRUSION. FOR RURAL APPLICATIONS 6' AND 12' SHALL BE THE LIMITING DIMENSIONS.
6. FOR UNIMPROVED AREAS "Y" SHALL BE A MINIMUM OF 80" HEIGHT FROM THE PAVEMENT SURFACE/SHOULDER.
7. SEE CITY STANDARD PLAN NO. 47 FOR STREET NAME SIGN INSTALLATION.
8. SIGNS SHALL BE CONSTRUCTED OF 0.08" THICK ALUMINUM ALLOY.
9. DISTANCE FROM LIMIT LINE TO TOP OF PAVEMENT LEGEND (STOP) SHALL BE 8'.

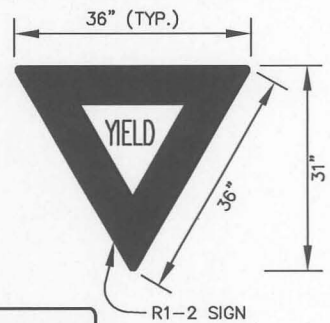

TOP OF GALVANIZED PIPE SHALL BE THREADED WITH GALVANIZED "PRESS ON" PIPE CAP (OR APPROVED EQUAL BY THE CITY ENGINEER) WHEN STREET NAME SIGNS ARE NOT REQUIRED

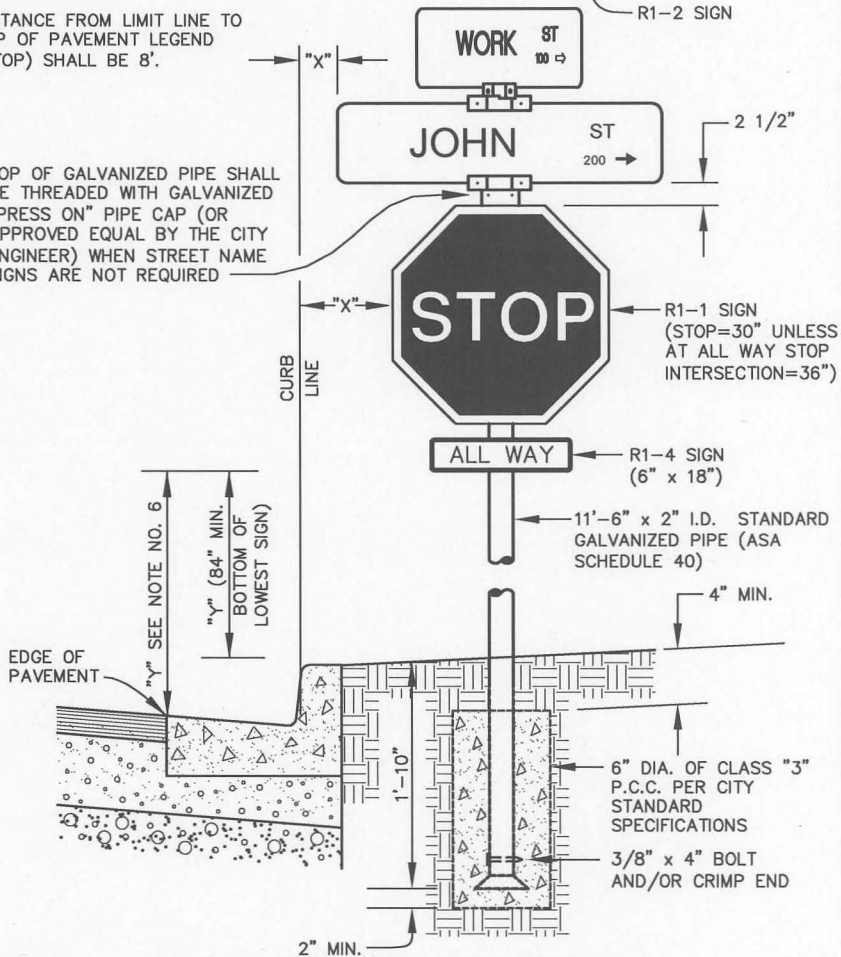

**SIGN INSTALLATION DETAIL**

**DEVELOPMENT & ENGINEERING SERVICES DEPARTMENT**  
ENGINEERING SERVICES DIVISION CITY OF SALINAS

---

TITLE: **TRAFFIC SIGNS (STOP/YIELD)** **STANDARD PLAN**

---

DESIGNED BY: STAFF	DATE: <u>10/21/2008</u>	
CADD BY: STAFF	<i>Robert Russell</i>	
PROJECT MANAGER: FRANK A. AGUAYO, P.E.	ROBERT C. RUSSELL, CITY ENGINEER R.C.E. 42871, EXPIRES 3-31-2010	
<b>48</b>		



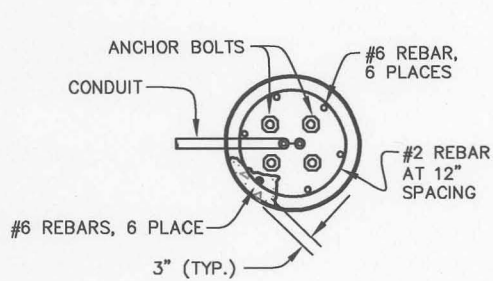

**SECTION A-A**

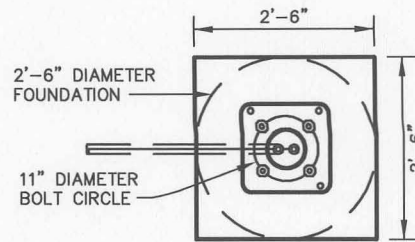

**SECTION B-B**

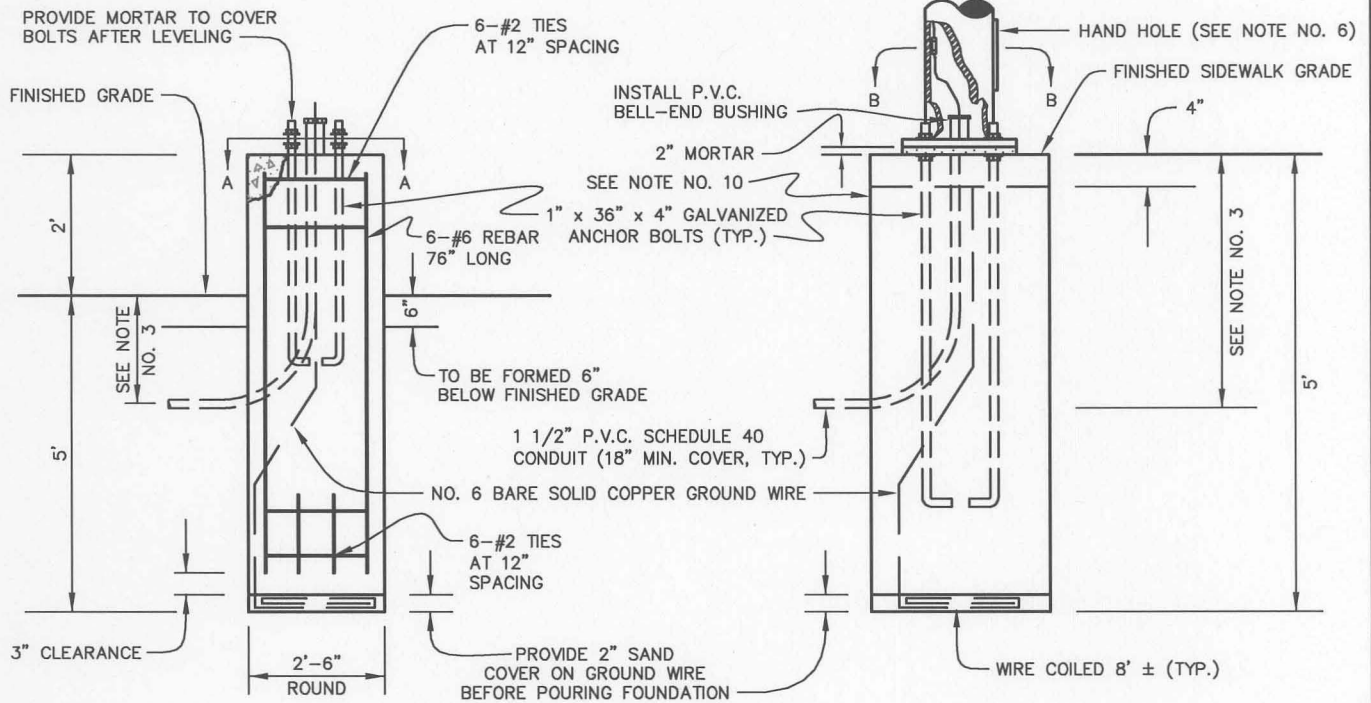

**PARKING AREA STREET LIGHT FOUNDATION**

**STREET LIGHT FOUNDATION**

**GENERAL NOTES**

1. DRAWING NOT TO SCALE.
2. ALL CONSTRUCTION AND MATERIALS SHALL CONFORM TO THE CITY STANDARD SPECIFICATIONS, ELECTRIC CODE, AND P.U.C.'S G.O. 95A.
3. CONDUIT COVER SHALL BE 18" MINIMUM IN SIDEWALK, PARKWAY STRIP, AND RAISED MEDIAN ISLAND AREAS AND 30" MINIMUM UNDER ROADWAY OR PROPERTY EASEMENTS.
4. ALL CONCRETE SHALL BE CLASS "3" PER CITY STANDARD SPECIFICATIONS.
5. CONTRACTOR SHALL FURNISH AND INSTALL ALL MATERIALS.
6. FOR STREET LIGHT BASE DETAILS AND PULLBOX INSTALLATION SEE CITY STANDARD PLAN NO. 51.
7. FOR STREET LIGHT POLE AND NUMBER LOCATION DETAIL SEE CITY STANDARD PLAN NO. 52.
8. FOR FUSE CONNECTOR SEE CITY STANDARD PLAN NO. 50.
9. FOR TYPICAL SERVICE POLE DETAIL AND UNDERGROUND SERVICE SEE CITY STANDARD PLAN NO. 51.
10. COMPLETE THIS PORTION OF FOUNDATION AFTER ERECTING AND LEVELING POLE.

**DEVELOPMENT & ENGINEERING SERVICES DEPARTMENT**  
ENGINEERING SERVICES DIVISION CITY OF SALINAS

<b>TITLE: P.C.C. LIGHTING FOUNDATION</b>	
DESIGNED BY: STAFF	DATE <u>10/21/2008</u>
CADD BY: STAFF	<i>Robert Russell</i>
PROJECT MANAGER: FRANK A. AGUAYO, P.E.	ROBERT C. RUSSELL, CITY ENGINEER R.C.E. 42871, EXPIRES 3-31-2010



**STANDARD PLAN**

**49**



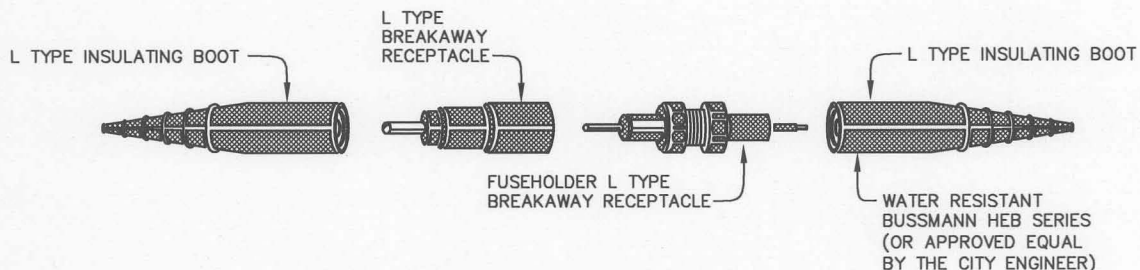

**DETAIL "A"**

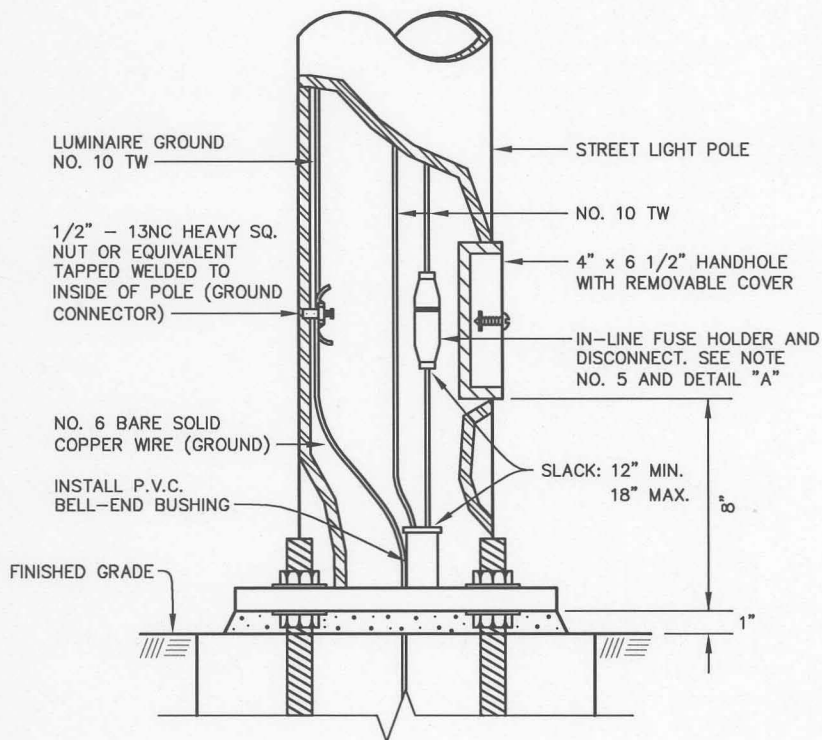

**FUSE CONNECTOR**

**GENERAL NOTES**

1. DRAWING NOT TO SCALE.
2. ALL CONSTRUCTION AND MATERIAL SHALL CONFORM TO THE CITY STANDARD SPECIFICATIONS, ELECTRIC CODE, AND P.U.C.'S G.O. 95A.
3. CONDUIT COVER SHALL BE 18" MINIMUM IN SIDEWALK, PARKWAY STRIP, AND RAISED MEDIAN ISLAND AREAS AND 30" MINIMUM UNDER ROADWAY OR PROPERTY EASEMENTS.
4. ALL CONCRETE SHALL BE CLASS "3" PER CITY STANDARD SPECIFICATIONS.
5. INSTALL WATERPROOF IN-LINE FUSE HOLDER BUSSMANN HEB SERIES (WATER RESISTANT) (OR APPROVED EQUAL BY THE CITY ENGINEER), UNDERGROUND LEG WITH MIDGET 10A FUSE \* OR AS DIRECTED BY CITY ENGINEER.
  - \* FUSE
  - 1 - HEAD 100W = 5 AMP
  - 2 - HEAD 100W = 7 AMP
  - 1 - HEAD 200W = 5 AMP
  - 2 - HEAD 200W = 10 AMP
6. THE CONTRACTOR SHALL FURNISH AND INSTALL ALL MATERIALS.
7. FOR STREET LIGHT POLE AND NUMBER LOCATION SEE CITY STANDARD PLAN NO. 52.
8. FOR STREET LIGHT BASE DETAILS AND PULLBOX INSTALLATION SEE CITY STANDARD PLAN NO. 51.
9. FOR TYPICAL SERVICE POLE DETAIL AND UNDERGROUND SERVICE SEE CITY STANDARD PLAN NO. 51.
10. FOR P.C.C. LIGHTING FOUNDATION SEE CITY STANDARD PLAN NO. 49.
11. FOR OVERHEAD POWER FEED, FUSE SHALL BE LOCATED INSIDE THE LUMINAIRE HEAD.

**DEVELOPMENT & ENGINEERING SERVICES DEPARTMENT**

ENGINEERING SERVICES DIVISION

CITY OF SALINAS

TITLE: **FUSE CONNECTOR**

**STANDARD PLAN**

DESIGNED BY:  
STAFF

DATE 10/21/2008

CADD BY:  
STAFF

*Robert C. Russell*



PROJECT MANAGER:  
FRANK A. AGUAYO, P.E.

ROBERT C. RUSSELL, CITY ENGINEER  
R.C.E. 42871, EXPIRES 3-31-2010

**50**

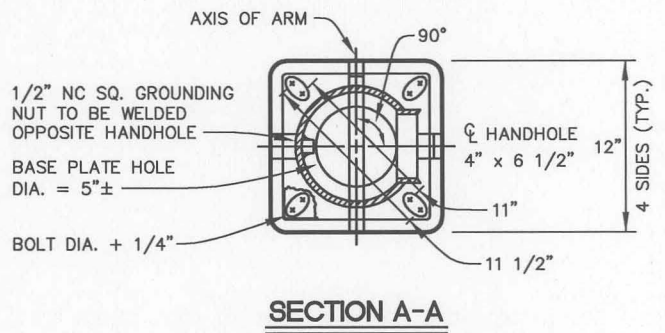
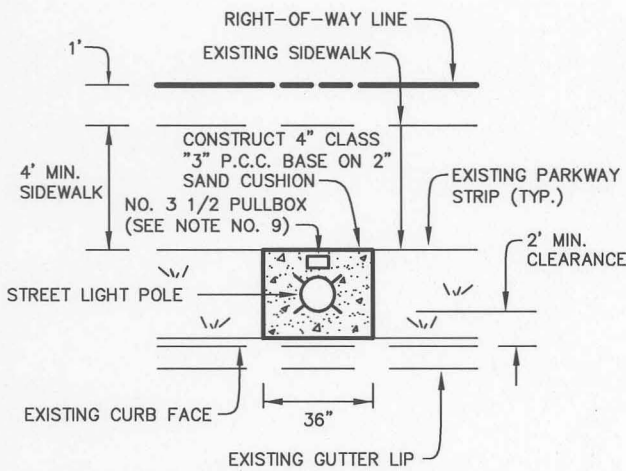
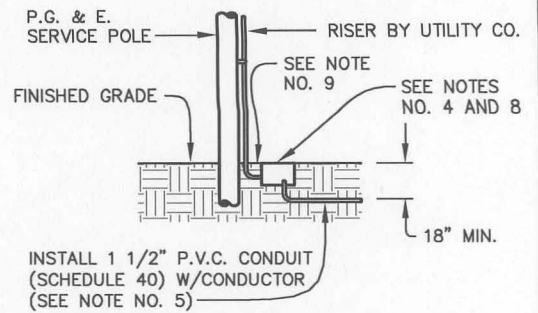
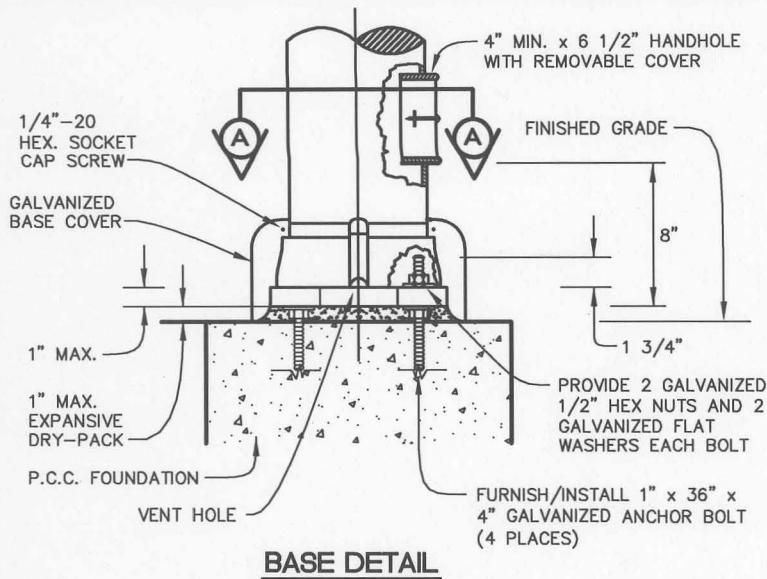

**ELECTROLIER BASE DETAIL IN PARKWAY**

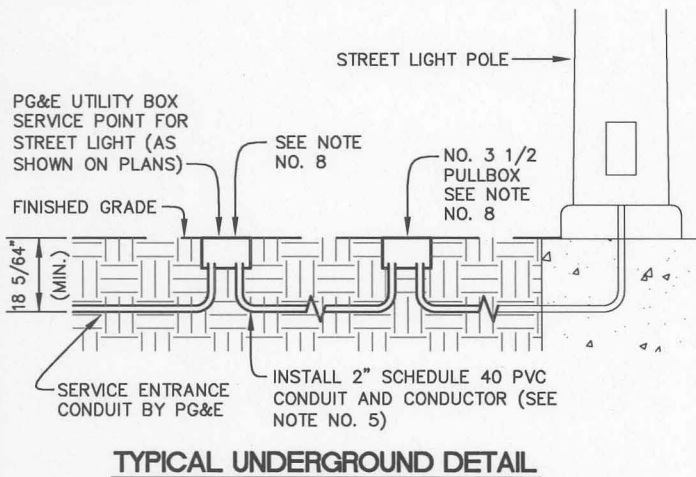

**GENERAL NOTES**

- DRAWING NOT TO SCALE.
- ALL CONCRETE SHALL BE CLASS "3" PER CITY STANDARD SPECIFICATIONS, EXCEPT AS OTHERWISE SPECIFIED ON PLANS.
- ALL CONSTRUCTION AND MATERIALS SHALL CONFORM TO THE STANDARD SPECIFICATIONS, ELECTRIC CODE, AND P.U.C.'S G.O. 95A.
- INSTALL NO. 3 1/2 PULLBOX AT BASE OF ALL EXISTING SERVICE POLES, VAULTS, AND STREET LIGHTS UNLESS OTHERWISE SPECIFIED ON THE PLANS. USE NO. 5 PULLBOX IF 4 OR MORE CONDUITS TERMINATE INTO THE BOX.
- CONDUIT COVER: 18" MINIMUM IN SIDEWALK, PARKWAY, AND RAISED MEDIAN ISLAND. 30" MINIMUM UNDER ROADWAY OR PROPERTY EASEMENT.
- FOR P.C.C. LIGHTING FOUNDATION SEE CITY STANDARD PLAN NO. 49. FOR STREET LIGHT POLE AND NUMBER LOCATION SEE CITY STANDARD PLAN NO. 52.
- FOR FUSE CONNECTOR SEE CITY STANDARD PLAN NO. 50.
- ALL STREET LIGHT PULLBOX COVERS SHALL BE LABELED "STREET LIGHTING".
- CITY OF SALINAS CONTRACTOR (FOR CITY FUNDED PROJECTS) SHALL INSTALL 2" SCHEDULE 40 PVC CONDUIT RISER TO PULLBOX (TWO 90° LONG SWEEP PLUS COUPLING).

<b>DEVELOPMENT &amp; ENGINEERING SERVICES DEPARTMENT</b>		CITY OF SALINAS
ENGINEERING SERVICES DIVISION		
<b>TITLE: STREET LIGHT BASE DETAILS AND PULLBOX INSTALLATION</b>		<b>STANDARD PLAN</b>
DESIGNED BY: STAFF	DATE: 10/21/2008	<h1>51</h1>
CADD BY: STAFF	<i>Robert C. Russell</i>	
PROJECT MANAGER: FRANK A. AGUAYO, P.E.	ROBERT C. RUSSELL, CITY ENGINEER R.C.E. 42871, EXPIRES 3-31-2010	

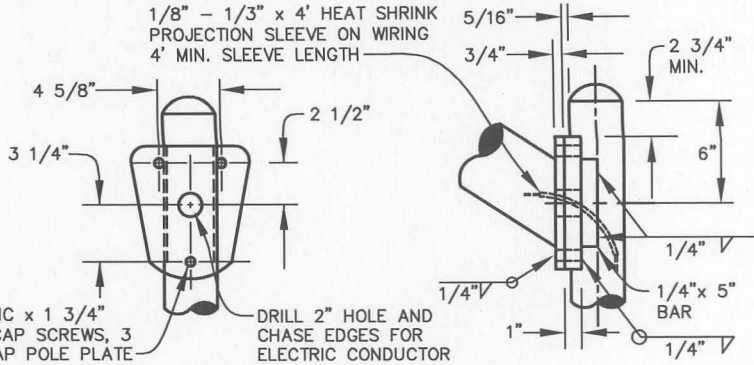
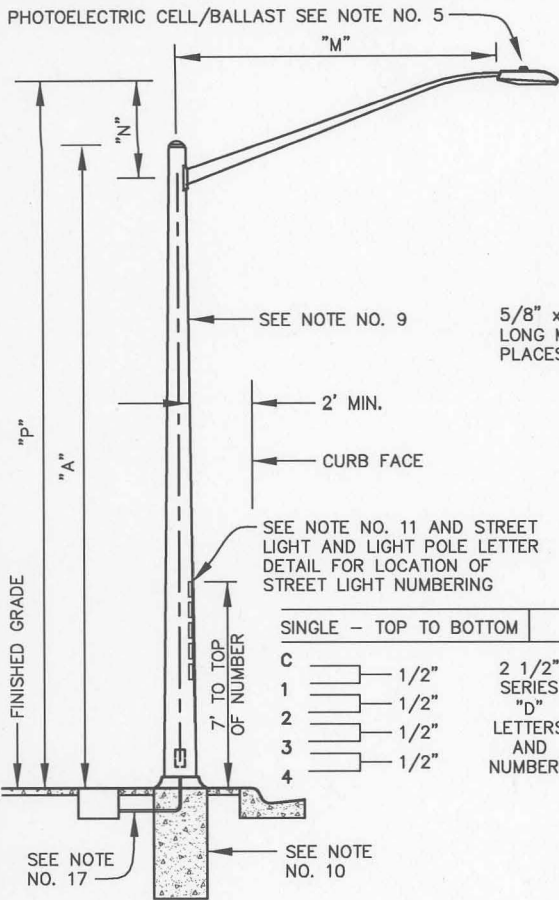

**LUMINAIRE ARM CONNECTION**

**GENERAL NOTES**

- DRAWING NOT TO SCALE.
- ALL CONSTRUCTION AND MATERIALS SHALL CONFORM TO THE CITY STANDARD SPECIFICATIONS, ELECTRIC CODE, AND P.U.C.'S G.O. 95A.
- LUMINAIRES AT 4-WAY (NON-SIGNALIZED) STREET INTERSECTIONS SHALL HAVE TYPE II 4-WAY I.E.S. DISTRIBUTION. TYPE III I.E.S. DISTRIBUTION ON OTHER LOCATIONS UNLESS OTHERWISE NOTED ON PLANS.
- POLES SHALL BE STEEL WITH HOT DIP GALVANIZED FINISH.
- PHOTOELECTRIC CELLS SHALL BE INTEGRALLY MOUNTED ON THE HOOD OF THE LIGHTING FIXTURE (DARK TO LIGHT MODEL #D120-1.0-S) (OR APPROVED EQUAL BY THE CITY ENGINEER). STARTER/IGNITOR SHALL BE SSI (STARTER SYSTEMS INCORPORATED) \* STARTER TRANSIENT SUPPRESSOR (OR APPROVED EQUAL BY THE CITY ENGINEER).
  - \* MODEL SCT03515 (35w TO 150w)
  - \* MODEL SCT1540 (150w TO 400w)
  - \* MODEL SCT40150 (400w TO 1500w)
- ALTERNATE DESIGN POLES, MOUNTING HEIGHTS, AND LIGHTING FIXTURES, WHEN APPROVED BY THE CITY ENGINEER, MAY BE INSTALLED IN SUBDIVISIONS. SUCH INSTALLATIONS SHALL BE OF A UNIFORM DESIGN THROUGHOUT THE SUBDIVISION.
- INSTALL NO. 3 1/2 PULLBOX AT BASE OF ALL EXISTING SERVICE POLE, VAULTS, AND STREET LIGHTS, UNLESS OTHERWISE SPECIFIED ON PLANS. USE NO. 5 PULLBOX IF 4 OR MORE CONDUITS CONNECT TO PULLBOX.
- PROJECTION LENGTHS ARE 8' MIN. FOR RESIDENTIAL AND 10' MIN. FOR COMMERCIAL, THICKNESS SHALL BE MIN. 0.1196" (11 GA. 55,000 PSI).
- STREET LIGHT POLE SHALL BE STATE TYPE 15, GALVANIZED: UNION METAL, AMERON, OR VALMONT (OR APPROVED EQUAL BY THE CITY ENGINEER).
- ALL CONCRETE SHALL BE CLASS "3" PER CITY STANDARD SPECIFICATIONS.
- CONTRACTOR SHALL INSTALL STREET LIGHT NUMBER (LETTER AND NUMBER) ON STREET LIGHT AND SHALL FACE PERPENDICULAR TO STREET IN RESIDENTIAL AREAS ONLY AND FACE ONCOMING TRAFFIC AT A 45° ANGLE ON OTHER STREETS. STREET NUMBERING LEGEND SHALL BE 2 1/2" HIGH, YELLOW WITH BLACK BACKGROUND REFLECTIVE VINYL, ADHESIVELY BACKED LETTER (PANDUIT PRL 250 YB-C) AND NUMBER (PANDUIT PRL 250 YB 0 TO 9) (OR APPROVED EQUAL BY THE CITY ENGINEER). STREET LIGHT NUMBERS TO BE ASSIGNED AFTER ALL STREET LIGHT FOUNDATIONS ARE POURED IN PLACE. THE CITY ENGINEER SHALL SUBMIT REQUEST TO PG&E FOR STREET LIGHT NUMBERS AT THAT TIME FOR ALL CITY FUNDED PROJECTS. PG&E SHALL RESPOND TO THE CITY ENGINEER WITHIN 10 WORKING DAYS.
- FOR FUSE CONNECTOR SEE CITY STANDARD PLAN NO. 50.
- FOR P.C.C. LIGHTING FOUNDATION SEE CITY STANDARD PLAN NO. 49.
- FOR TYPICAL SERVICE POLE DETAIL, UNDERGROUND SERVICE, AND BASE DETAIL SEE CITY STANDARD PLAN NO. 51.
- WATTAGE SHALL BE 150 WATTS FOR RESIDENTIAL AND 200 WATTS ON ALL OTHER ROADS, AND TRAFFIC SIGNAL POLES UNLESS OTHERWISE NOTED ON PLANS.
- SPACING OF STREET LIGHTS SHALL BE DETERMINED BY THE CITY ENGINEER.
- CONDUIT COVER: 18" MINIMUM IN SIDEWALK, PARKWAY STRIP, AND RAISED MEDIAN ISLAND. 30" MINIMUM UNDER ROADWAY OR PROPERTY EASEMENT.
- LUMINAIRES SHALL BE CUT-OFF LENSE (EXCEPT TYPE III 4-WAY LUMINAIRE) HIGH PRESSURE SODIUM VAPOR W/TYPE IV P.E. CELL AND REGULATOR TYPE BALLAST. WATTAGE AND 120V AS SHOWN ON PLANS. AMERICAN ELECTRIC, OR G.E. (OR APPROVED EQUAL BY THE CITY ENGINEER).
- CONSTRUCTION OF STAB-IN POLES SHALL NOT BE PERMITTED.
- ALL STREET LIGHT PULLBOX COVERS SHALL BE LABELED "STREET LIGHTING".

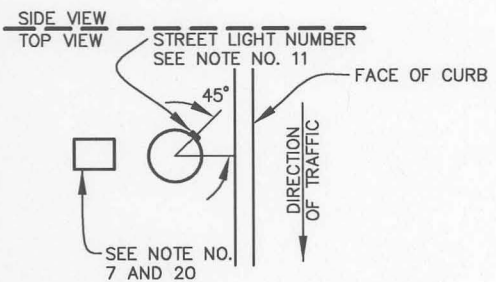

**STREET LIGHT AND LIGHT POLE LETTER DETAIL**

MAST ARM DATA			
"M" PROJECTED LENGTH (MIN.)	"N" RISE	MIN. O.D. AT POLE	"P" MOUNTING HEIGHT TYPE 15
10' - 0"	3' - 3" ±	3 7/8"	32' - 9" ±
12' - 0"	4' - 3" ±	3 7/8"	33' - 9" ±
15' - 0"	4' - 9" ±	4 1/4"	34' - 3" ±

POLE DATA				
POLE TYPE	"A" HEIGHT	MIN. O.D.		THICKNESS
		BASE	TOP	
15	30' - 0"	8"	3 7/8"	0.1196"

**DEVELOPMENT & ENGINEERING SERVICES DEPARTMENT**

ENGINEERING SERVICES DIVISION CITY OF SALINAS

---

**TITLE: STREET LIGHT POLE AND NUMBER LOCATION** **STANDARD PLAN**

DESIGNED BY: STAFF	DATE: 10/21/2008	
CADD BY: STAFF	<i>Robert C. Russell</i>	
PROJECT MANAGER: FRANK A. AGUAYO, P.E.	ROBERT C. RUSSELL, CITY ENGINEER R.C.E. 42871, EXPIRES 3-31-2010	

52

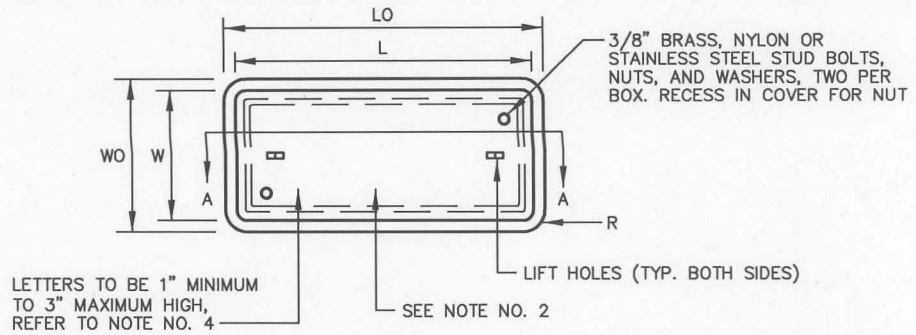

**TOP VIEW**

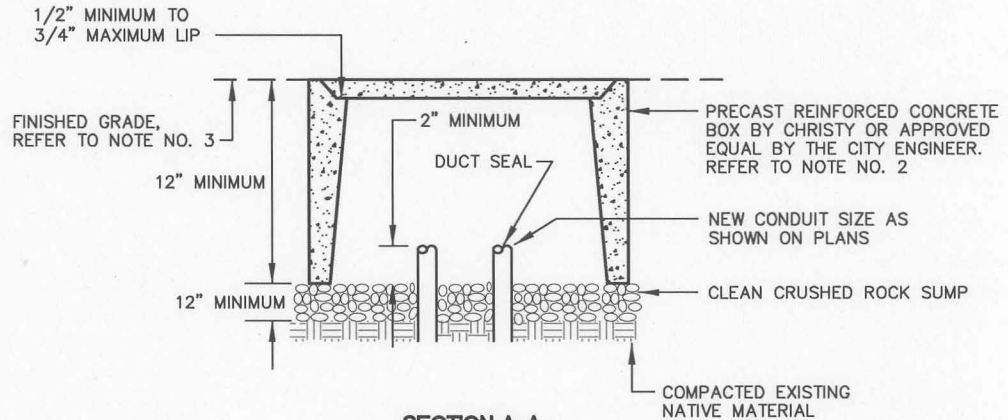

**SECTION A-A**

**DIMENSION TABLE**

PULLBOX	CONCRETE BOX			CONCRETE COVERS						
	MIN. ** THICKNESS	MIN. DEPTH BOX AND EXTENSION	LO	WO	L***	W***	R	EDGE THICKNESS	EDGE TAPER	
NO. 3	1 1/2"	1"	NO EXTENSION	20"	14"	15 3/8"	10 1/8"	1 1/8"	1 3/4"	1/8"
NO. 5	1"	22"	22"	28"	18"	23 1/4"	13 3/4"	1 1/4"	2"	1/8"
NO. 6	1 1/2"	24"	24"	36"	23"	30 5/8"	17 5/8"	1 1/4"	2"	1/8"

**GENERAL NOTES**

- DRAWING NOT TO SCALE.
- STEEL REINFORCING SHALL BE AS REGULARLY USED IN THE STANDARD PRODUCTS OF THE RESPECTIVE MANUFACTURER.
- TOP OF PULLBOX SHALL BE FLUSH WITH SURROUNDING GRADE OR TOP OF ADJACENT CURB, EXCEPT THAT IN UNPAVED AREAS WHERE PULLBOX IS NOT IMMEDIATELY ADJACENT TO, AND PROTECTED BY A CONCRETE FOUNDATION, POLE, OR OTHER PROTECTIVE CONSTRUCTION, THE BOX SHALL BE PLACED WITH ITS TOP 0.10' ABOVE SURROUNDING GRADE. WHERE PRACTICABLE, PULLBOXES SHOWN IN THE VICINITY OF CURBS SHALL BE PLACED ADJACENT TO THE BACK OF CURB, AND PULLBOXES SHOWN ADJACENT TO STANDARDS SHALL BE PLACED ON SIDE OF FOUNDATION FACING AWAY FROM TRAFFIC, UNLESS OTHERWISE NOTED ON PLANS.
- DEPENDING ON APPLICATION PULLBOX COVERS SHALL BE LABELED: STREET LIGHT, TRAFFIC SIGNAL, IRRIGATION, ETC.
- THE NOMINAL DIMENSIONS OF THE OPENING IN WHICH THE COVER SETS SHALL BE THE SAME AS THE DIMENSIONS EXCEPT THE LENGTH AND WIDTH DIMENSIONS SHALL BE 1/8" GREATER.
- WHEN A PULLBOX IS INSTALLED IN THE SIDEWALK AREA, THE DEPTH OF THE PULLBOX SHALL BE ADJUSTED SO THAT THE TOP OF THE BOX IS FLUSH WITH THE TOP OF THE SIDEWALK.
- TRAFFIC PULLBOX SHALL BE PROVIDED WITH A STEEL COVER AND SPECIAL CONCRETE FOOTING 3" MINIMUM CLASS "2" P.C.C. ON ALL SIDES OF BOX. STEEL COVER SHALL HAVE EMBOSSED NON-SKID PATTERN. GROUT BOTTOM OF BOXES WITH TRAFFIC LIDS AND PROVIDE DRAIN HOLE.

**DEVELOPMENT & ENGINEERING SERVICES DEPARTMENT**

ENGINEERING SERVICES DIVISION

CITY OF SALINAS

TITLE: **PULLBOX**

**STANDARD PLAN**

DESIGNED BY:  
STAFF

DATE 10/21/2008

CADD BY:  
STAFF

*Robert C. Russell*

PROJECT MANAGER:  
FRANK A. AGUAYO, P.E.

ROBERT C. RUSSELL, CITY ENGINEER  
R.C.E. 42871, EXPIRES 3-31-2010



**53**



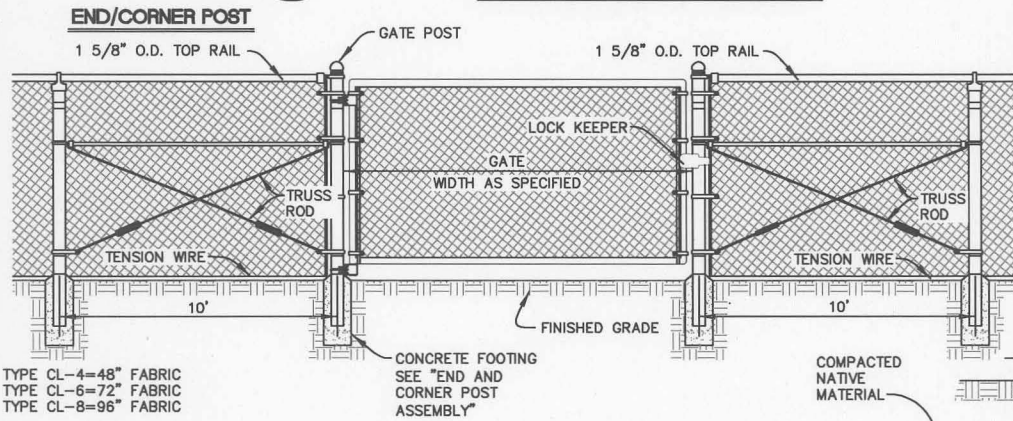
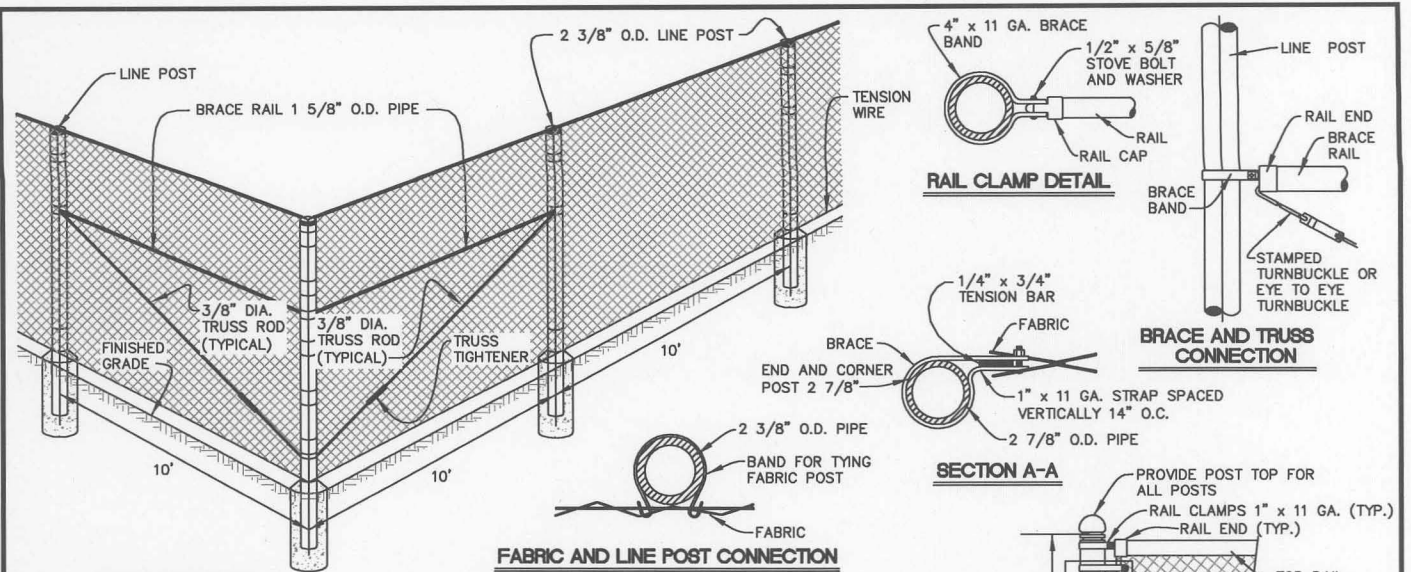

TYPE CL-4=48" FABRIC  
 TYPE CL-6=72" FABRIC  
 TYPE CL-8=96" FABRIC

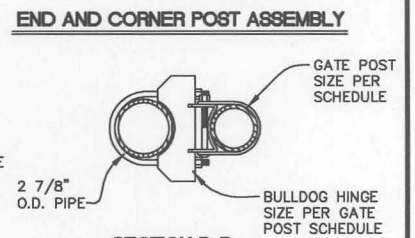
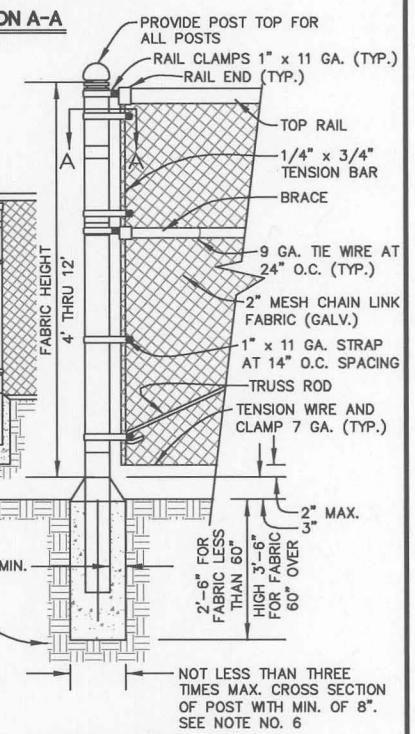
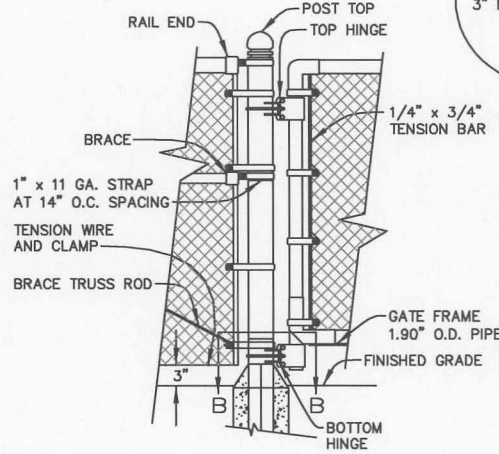
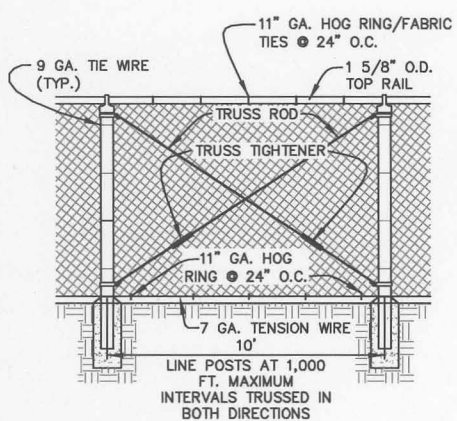

**GENERAL NOTES**

- DRAWING NOT TO SCALE.
- CHAIN LINK FABRIC SHALL BE 11 GAUGE FOR ALL FENCES 60" OR LESS IN HEIGHT AND SHALL BE 9 GAUGE FOR ALL FENCES OVER 60" IN HEIGHT, UNLESS OTHERWISE SPECIFIED.
- IN BALL PARK AREA, CHAIN LINK FENCE FABRIC SHALL BE 9 GAUGE FOR ALL HEIGHTS UNLESS OTHERWISE SPECIFIED.
- TRUSS RODS SHALL HAVE TRUSS TIGHTENERS OR ADJUSTABLE TAKE-UP APPROVED BY THE CITY ENGINEER.
- GATE SHALL BE PROVIDED WITH LOCK KEEPER. IF BEAM TYPE POST IS TO BE USED, TYPE AND SIZES SHALL BE APPROVED BY THE CITY ENGINEER BEFORE CONSTRUCTION.
- ALL CONCRETE SHALL BE CLASS "3" PER CITY STANDARD SPECIFICATIONS.
- ALL PIPE SHALL BE SCHEDULE 40 GALVANIZED STEEL.
- TOP RAIL SHALL BE 1 5/8" O.D. PIPE.

**SECTION B-B**

**GATE POST SCHEDULE**

HEIGHT	GATE WIDTH	SIZE O. D.
6' AND LESS	UP TO 6'	3"
	7' TO 13'	4"
	14' TO 18'	6"
OVER 6'	OVER 18'	8"
	UP TO 6'	3 1/2"
	7' TO 13'	4 1/2"
	14' TO 18'	6 1/2"
OVER 18'	8 1/2"	

**DEVELOPMENT & ENGINEERING SERVICES DEPARTMENT**

ENGINEERING SERVICES DIVISION CITY OF SALINAS

---

**TITLE: CHAIN LINK FENCE**

DESIGNED BY: **STAFF** DATE: 10/21/2008

CADD BY: **STAFF**

PROJECT MANAGER: **FRANK A. AGUAYO, P.E.**

ROBERT C. RUSSELL, CITY ENGINEER  
 R.C.E. 42871, EXPIRES 3-31-2010



54

STANDARD PLAN

ALL MASONRY NON-ACCESS WALL  
DESIGNS SHALL BE SUBMITTED TO THE  
CITY ENGINEER AND BUILDING OFFICIAL  
FOR REVIEW AND APPROVAL.

GENERAL NOTES

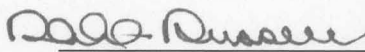
- DESIGN SHALL BE BY A REGISTERED ENGINEER LICENSED IN THE STATE OF CALIFORNIA.

<b>DEVELOPMENT &amp; ENGINEERING SERVICES DEPARTMENT</b>		CITY OF SALINAS
ENGINEERING SERVICES DIVISION		
TITLE: <b>MASONRY NON-ACCESS WALL</b>		<b>STANDARD PLAN</b>
DESIGNED BY: STAFF	DATE <u>10/21/2008</u>	<b>55</b>
CADD BY: STAFF		
PROJECT MANAGER: FRANK A. AGUAYO, P.E.	ROBERT C. RUSSELL, CITY ENGINEER R.C.E. 42871, EXPIRES 3-31-2010	
		

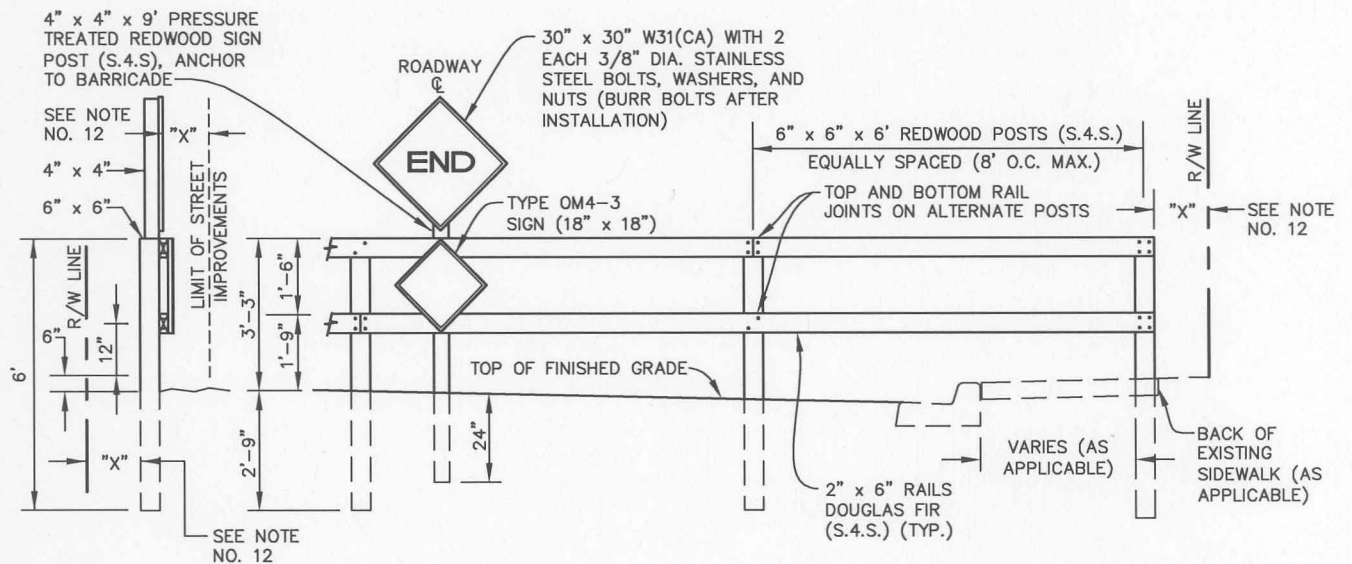

**GENERAL NOTES**

1. DRAWING NOT TO SCALE.
2. MINIMUM SPACING OF POSTS SHALL BE 8' CENTER TO CENTER.
3. ALL DIMENSIONS ARE NORMAL LUMBER DIMENSIONS.
4. BREAKAWAY HOLES REQUIRED UNLESS DESIGNED OTHERWISE, AND APPROVED BY THE CITY ENGINEER.
5. COMPLETED BARRICADE SHALL BE PAINTED WITH 2 COATS OF APPROVED TRAFFIC YELLOW PAINT PER SECTION 59 OF THE CITY STANDARD SPECIFICATIONS.
6. PORTIONS OF POST BELOW GRADE SHALL BE ASPHALT COATED (DIPPED).
7. STAINLESS STEEL LAG BOLTS (2 EACH 3/8"Ø) AND WASHERS (MINIMUM 4) REQUIRED AT RAIL SPLICES AND AT END POSTS. NORMAL WIDTH OF BARRICADE: AS MEASURED TO CENTER OF END POSTS.
8. SIGNS SHALL BE CONSTRUCTED OF 0.08" THICK ALUMINUM ALLOY.
9. ALL SIGNS SHALL HAVE 3M DIAMOND GRADE CUBED REFLECTIVE SHEETING SERIES 4090 OR APPROVED EQUAL BY THE CITY ENGINEER. THE REFLECTIVE SHEETING SHALL CONFORM WITH FEDERAL SPECIFICATIONS L-S300A.
10. THE BACKGROUND OF SIGN W31(CA) SHALL BE YELLOW WITH BLACK BORDER AND LETTERS, AND EVERYTHING SHALL BE REFLECTIVE.
11. THE SIGN TYPE OM4-3 SHALL BE RED 3M DIAMOND GRADE CUBED REFLECTIVE SHEETING SERIES 4090.
12. X=1' UNLESS OTHERWISE SPECIFIED ON PLAN, AND APPROVED BY THE CITY ENGINEER.

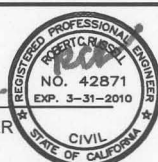
<b>DEVELOPMENT &amp; ENGINEERING SERVICES DEPARTMENT</b>		CITY OF SALINAS
ENGINEERING SERVICES DIVISION		
TITLE:	<b>WOODEN RAIL BARRICADE</b>	<b>STANDARD PLAN</b>
DESIGNED BY: STAFF	DATE <u>10/21/2008</u>	<b>56</b>
CADD BY: STAFF	<i>Robert C. Russell</i>	
PROJECT MANAGER:	ROBERT C. RUSSELL, CITY ENGINEER R.C.E. 42871, EXPIRES 3-31-2010	
FRANK A. AGUAYO, P.E.		

**GENERAL NOTES**

- SEE CITY STANDARD PLAN NO. 57B FOR GENERAL NOTES REFERENCED ON THIS PLAN.

2' LANDSCAPE STRIP (SEE NOTE NO. 8)

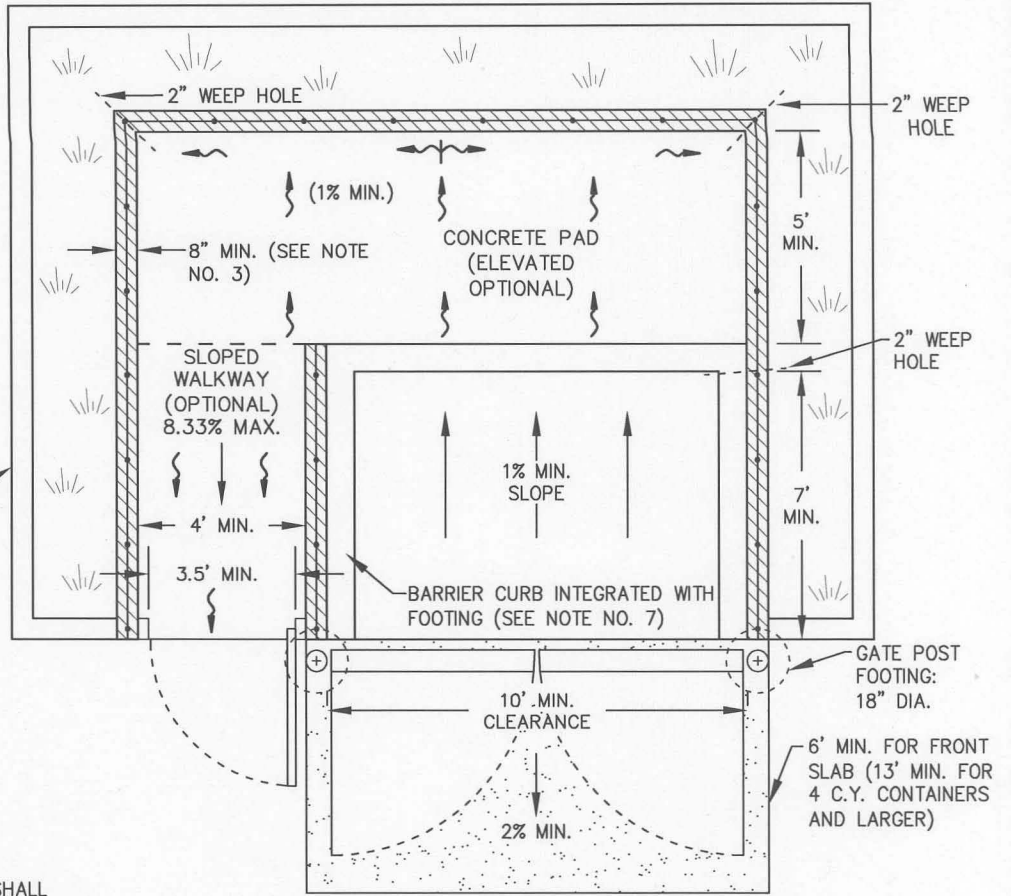

**PLAN VIEW**

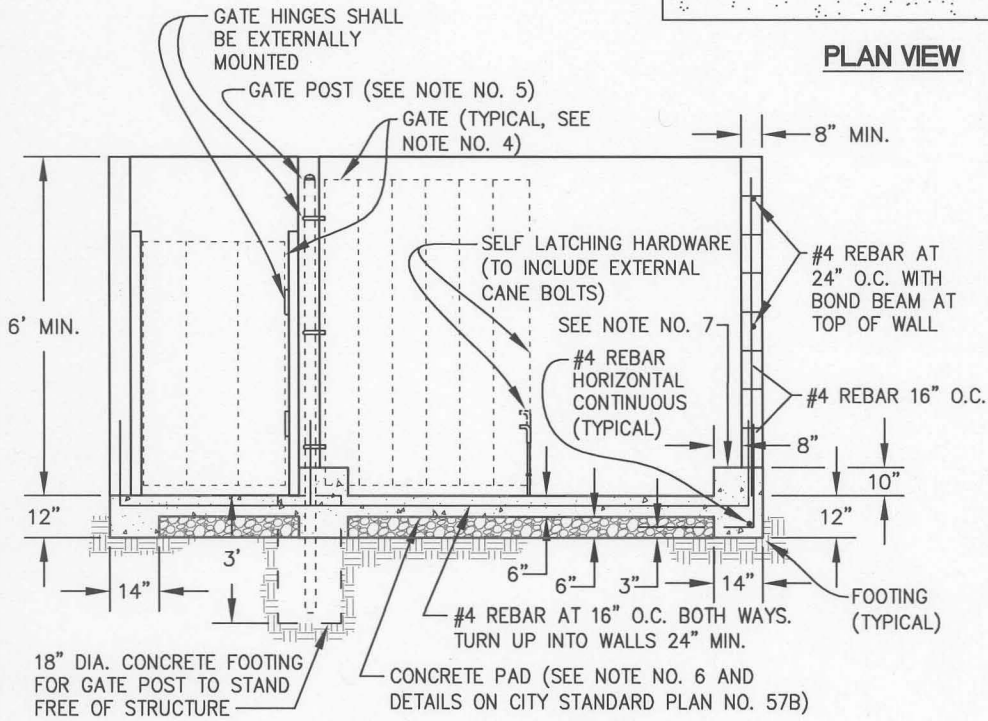

**FRONT ELEVATION VIEW**

DEVELOPMENT & ENGINEERING SERVICES DEPARTMENT  
 ENGINEERING SERVICES DIVISION CITY OF SALINAS

TITLE: <b>STANDARD TRASH ENCLOSURE</b>	
DESIGNED BY: STAFF	DATE: <u>10/21/2008</u> DATE APPROVED AND
CADD BY: STAFF	<i>Robert C. Russell</i>
PROJECT MANAGER: DALE ROSSKAMP, P.E.	ROBERT C. RUSSELL, CITY ENGINEER R.C.E. 42871, EXPIRES 3-31-2010



STANDARD PLAN  
**57A**



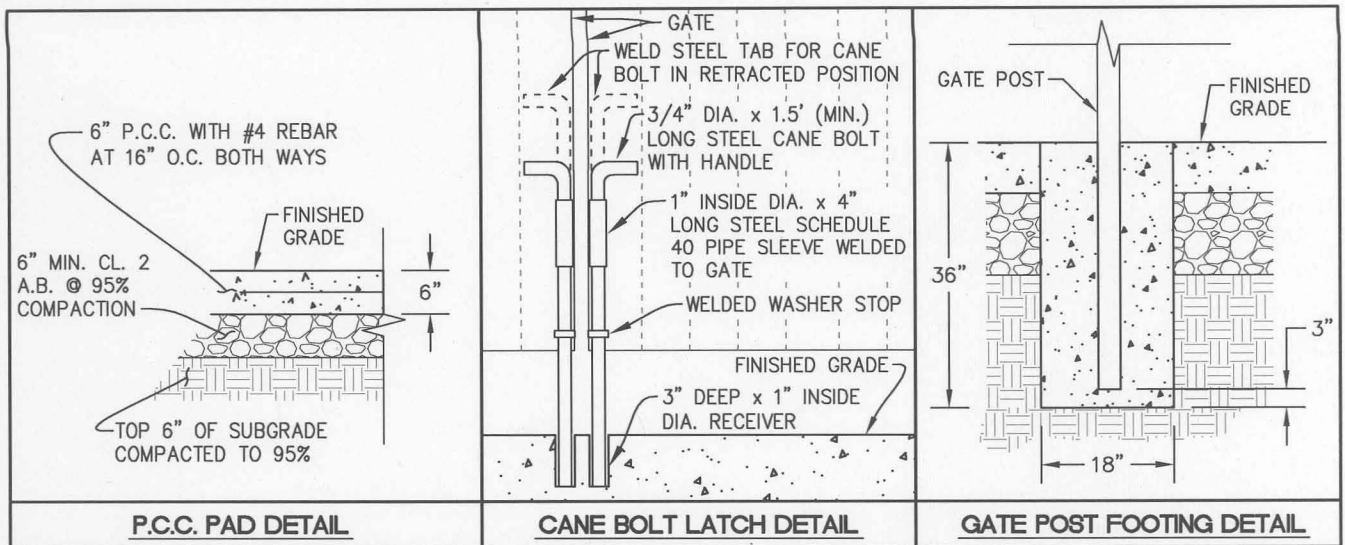

**GENERAL NOTES**

1. DRAWINGS NOT TO SCALE.
2. TRASH AREA TO BE LOCATED SO AS TO BE ACCESSIBLE TO BOTH DEPOSIT AND PICKUP. LOCATION TO BE APPROVED BY CITY ENGINEER.
3. 8" MASONRY BLOCK CONSTRUCTION WITH STANDARD STEEL REINFORCING REBAR. FILL ALL CELLS WITH CLASS "2" P.C.C., SMOOTH TOP WITH STEEL TROWEL FINISH. EXTERIOR SURFACE FINISH SHALL BE COMPATIBLE WITH THE MAIN STRUCTURE(S).
4. METAL GATES AND HEAVY DUTY HARDWARE SHALL BE USED, UNLESS OTHERWISE APPROVED BY THE CITY ENGINEER. METAL PANEL GATES SHALL TOTALLY SCREEN THE TRASH BINS (TYPICAL) AND SHALL BE ARCHITECTURALLY COMPATIBLE WITH THE PROJECT.
5. GATE POSTS SHALL BE MINIMUM 4" DIA. (CIRCULAR/SQUARE) GALVANIZED STEEL SET IN CLASS "2" P.C.C. FREESTANDING FROM THE ENCLOSURE STRUCTURE.
6. PAD SHALL BE 6" THICK CLASS "2" P.C.C. OVER 6" MINIMUM CLASS 2 A.B. FINISHED PAD ELEVATION SHALL MEET THE FINISHED PAVING ELEVATION.
7. INSTALL 8" x 10" BARRIER CURB WITH FOOTING COMPLETELY AROUND INSIDE OF ENCLOSURE TO ACT AS TRASH BIN BUMPER GUARD. POUR MONOLITHICALLY WITH FOOTING.
8. A 2' LANDSCAPE STRIP, EXCLUSIVE TO THE ENCLOSURE WITH TYPE "B" CURB PER CITY STANDARD PLAN NO. 1, SHALL BE PROVIDED AROUND THE PERIMETER OF THE ENCLOSURE.
9. COLORS SHALL MATCH OR BE COMPATIBLE WITH THE DEVELOPMENT.
10. CANE BOLT LATCHES SHALL BE "HEAVY DUTY" AS SHOWN OR APPROVED EQUAL BY THE CITY ENGINEER.
11. CITY ENGINEER SHALL HAVE THE OPTION TO APPROVE AN EQUIVALENT TRASH ENCLOSURE TO MEET SPECIAL SITE SPECIFIC CONDITIONS.

NOTE: SIZES ARE REPRESENTATIVE AND MAY VARY BASED UPON THE DISPOSAL NEEDS OF THE OPERATION OR ON-SITE CONSTRAINTS.

<b>DEVELOPMENT &amp; ENGINEERING SERVICES DEPARTMENT</b>		CITY OF SALINAS
ENGINEERING SERVICES DIVISION		
<b>TITLE: STANDARD TRASH ENCLOSURE DETAILS</b>		<b>STANDARD PLAN</b>
DESIGNED BY: STAFF	DATE <u>10/21/2008</u> DATE APPROVED AND <i>Robert C. Russell</i>	<b>57B</b>
CADD BY: STAFF	 ROBERT C. RUSSELL, CITY ENGINEER R.C.E. 42871, EXPIRES 3-31-2010	
PROJECT MANAGER: DALE ROSSKAMP, P.E.		

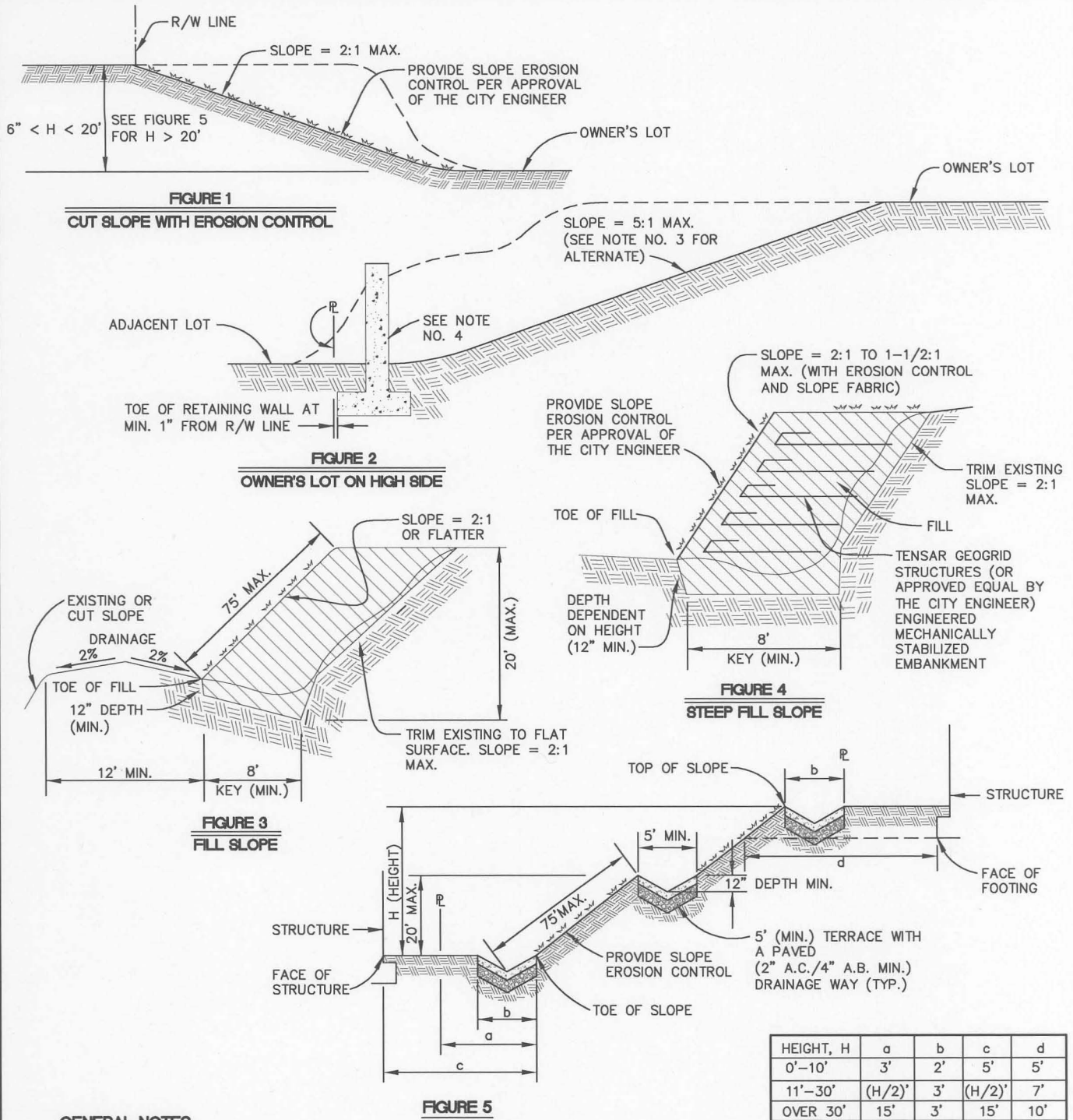

HEIGHT, H	a	b	c	d
0'-10'	3'	2'	5'	5'
11'-30'	(H/2)'	3'	(H/2)'	7'
OVER 30'	15'	3'	15'	10'

CUT AND FILL SETBACKS

**DEVELOPMENT & ENGINEERING SERVICES DEPARTMENT**

ENGINEERING SERVICES DIVISION CITY OF SALINAS

---

TITLE: **SLOPE GRADING** **STANDARD PLAN**

DESIGNED BY: STAFF	DATE: 10/21/2008		<h1 style="margin: 0;">58</h1>
CADD BY: STAFF			
PROJECT MANAGER: FRANK A. AGUAYO, P.E.	ROBERT C. RUSSELL, CITY ENGINEER R.C.E. 42871, EXPIRES 3-31-2010		

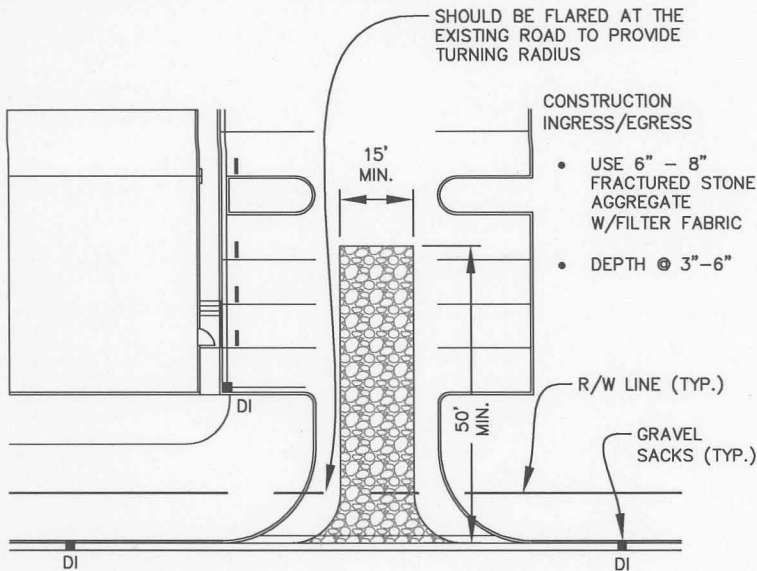

**TYPICAL CONSTRUCTION ENTRY REQUIREMENT**

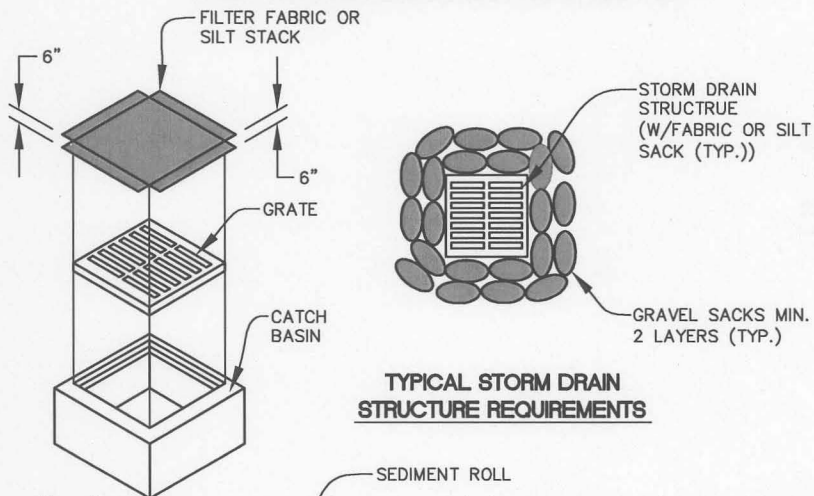

**TYPICAL STORM DRAIN STRUCTURE REQUIREMENTS**

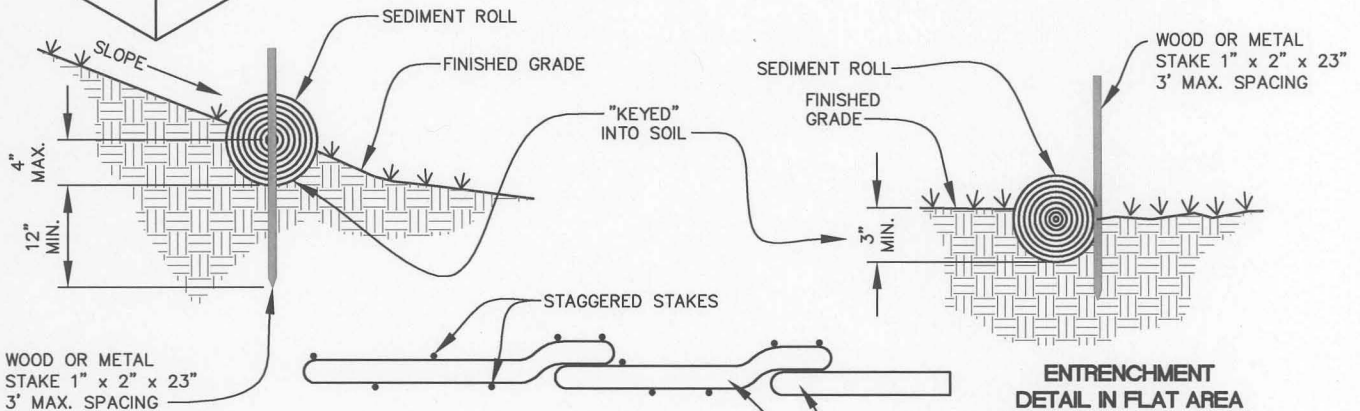

**ENTRENCHMENT DETAIL IN SLOPE AREA**  
(FOR SHORT SLOPES OR SLOPES FLATTER THAN 3:1)

**SEDIMENT LOG DETAIL**  
(TO BE USED ON SLOPES AT PROPERTY PERIMETER)

**ENTRENCHMENT DETAIL IN FLAT AREA**

**GENERAL NOTE**

1. DRAWING NOT TO SCALE.
2. GRAVEL BAGS SHALL BE USED ON ALL DRAINAGE INLETS; ON-SITE TOP OPENINGS AND SIDE OPENINGS.
3. GRAVEL BAGS SHALL BE USED ON ALL DRAINAGE INLETS WITHIN THE CITY OF SALINAS RIGHT-OF-WAY IMPACTED BY THE PROJECT (DOWN STREAM INLETS AND FIRST INLET UP STREAM)
4. PLACE TYPE I BARRICADE OVER DRAINAGE INLET WHEN FILTER FABRIC AND GRAVEL SACKS ARE UTILIZED.
5. INSPECT (AND DOCUMENT EACH INSPECTION) ALL INLET PROTECTION DEVICES BEFORE AND AFTER RAINFALL EVENTS, AND WEEKLY THROUGHOUT RAINY SEASON. DURING EXTENDED RAINFALL EVENTS, INSPECT INLET PROTECTION DEVICES AT LEAST ONCE EVERY 24 HOURS.
6. REMOVE ALL INLET PROTECTION DEVICES WITHIN 30 CALENDAR DAYS AFTER THE SITE IS STABILIZED, OR WHEN INLET PROTECTION IS NO LONGER REQUIRED.
7. PRIOR TO ROLL INSTALLATION, CONTOUR A CONCAVE KEY TRENCH 3" MINIMUM TO 4" MAXIMUM DEEP ALONG THE PROPOSED INSTALLATION ROUTE.
8. SOIL EXCAVATED IN TRENCHING SHOULD BE PLACED ON THE UPHILL OR FLOW SIDE OF THE ROLL TO PREVENT WATER FROM UNDER CUTTING THE ROLL.
9. PLACE SEDIMENT ROLL INTO KEY TRENCH AND STAKE ON BOTH SIDES OF THE ROLL TO WITHIN 3' OF EACH END AND THEN EVERY 3' WITH 1" x 2" x 23" WOOD OR METAL STAKES.
10. STAKES ARE TYPICALLY DRIVEN IN ON ALTERNATING SIDES OF THE ROLL. WHEN MORE THAN ONE SEDIMENT ROLL IS PLACED IN A ROW, THE ROLLS SHOULD BE OVERLAPPED 12" MIN. TO PROVIDE A TIGHT JOIN, NOT ABUTTED TO ONE ANOTHER.

**DEVELOPMENT & ENGINEERING SERVICES DEPARTMENT**

ENGINEERING SERVICES DIVISION

CITY OF SALINAS

TITLE: **BEST MANAGEMENT PRACTICES**

**STANDARD PLAN**

DESIGNED BY:  
STAFF  
CADD BY:  
STAFF  
PROJECT MANAGER:  
FRANK A. AGUAYO, P.E.

DATE 10/21/2008

*Robert C. Russell*

ROBERT C. RUSSELL, CITY ENGINEER  
R.C.E. 42871, EXPIRES 3-31-2010



**59A**

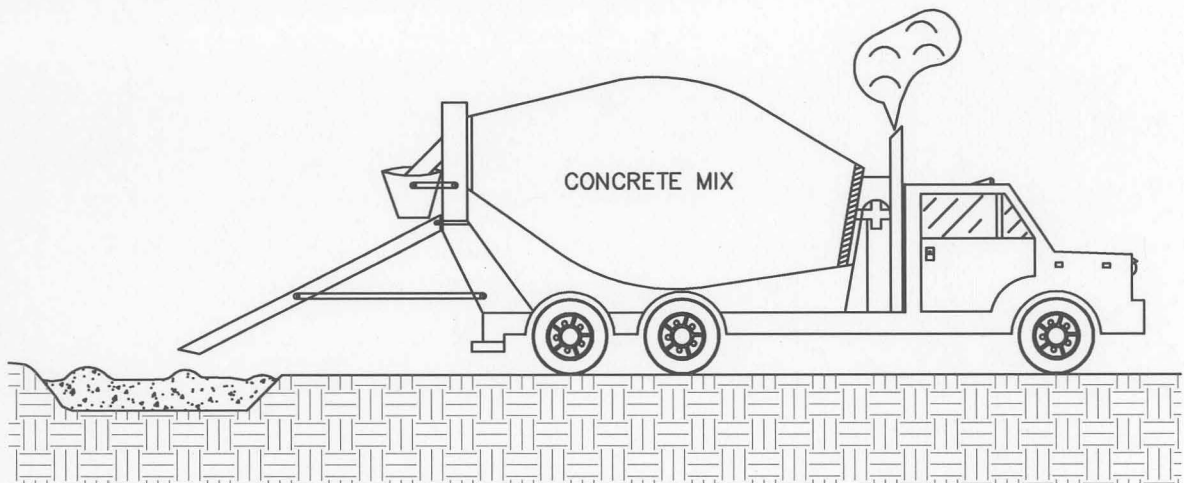

NOT TO SCALE



**DESCRIPTION**

PREVENT OR REDUCE THE DISCHARGE OF POLLUTANTS TO STORM WATER FROM CONCRETE WASTE BY CONDUCTING WASHOUT OFF-SITE, PERFORMING ON-SITE WASHOUT IN A DESIGNATED AREA, AND TRAINING EMPLOYEES AND SUBCONTRACTORS.

**APPROACH**

THE FOLLOWING STEPS SHALL HELP REDUCE STORM WATER POLLUTION FROM CONCRETE WASTES:

- STORE DRY AND WET MATERIALS UNDER COVER, AWAY FROM DRAINAGE AREAS.
- AVOID MIXING EXCESS AMOUNTS OF FRESH CONCRETE OR CEMENT ON-SITE.
- PERFORM WASHOUT OF CONCRETE TRUCKS OFF SITE OR IN DESIGNATED AREAS ONLY.
- DO NOT WASH OUT CONCRETE TRUCKS INTO STORM DRAINS, OPEN DITCHES, STREETS, OR STREAMS.
- DO NOT ALLOW EXCESS CONCRETE TO BE DUMPED ON-SITE, EXCEPT IN DESIGNATED AREAS.
- FOR ON-SITE WASHOUT:
  - LOCATE WASHOUT AREA AT LEAST 50' FROM STORM DRAINS, OPEN DITCHES, OR WATER BODIES. DO NOT ALLOW RUNOFF FROM THIS AREA BY CONSTRUCTING A TEMPORARY PIT OR BERMED AREA LARGE ENOUGH FOR LIQUID AND SOLID WASTE.
  - WASH OUT WASTES INTO THE TEMPORARY PIT WHERE THE CONCRETE CAN SET, BE BROKEN UP, AND THEN DISPOSED OF PROPERLY.
- WHEN WASHING CONCRETE TO REMOVE FINE PARTICLES AND EXPOSE THE AGGREGATE, AVOID CREATING RUNOFF BY DRAINING THE WATER TO A BERMED OR LEVEL AREA.
- DO NOT WASH SWEEPINGS FROM EXPOSED AGGREGATE CONCRETE INTO THE STREET OR STORM DRAIN. COLLECT AND RETURN SWEEPINGS TO AGGREGATE BASE STOCK PILE, OR DISPOSE IN THE TRASH.

<b>DEVELOPMENT &amp; ENGINEERING SERVICES DEPARTMENT</b>		CITY OF SALINAS
ENGINEERING SERVICES DIVISION		
<b>TITLE: CONCRETE WASTE WASHOUT MANAGEMENT PLAN</b>		<b>STANDARD PLAN</b>  <b>59B</b>
DESIGNED BY: STAFF	DATE <u>10/21/2008</u>	
CADD BY: STAFF		
PROJECT MANAGER: FRANK A. AGJAYO, P.E.	 <p>ROBERT C. RUSSELL, CITY ENGINEER R.C.E. 42871, EXPIRES 3-31-2010</p>	